

# M51132L/FP

## 2CH ELECTRONIC VOLUME·BALANCE

### DESCRIPTION

The M51132 is a VCA (Voltage Controlled Amplifier) IC developed as an electronic volume control for audio-visual equipment. The IC is used to process small analog signals at the stage before power amplifier. Right/left independent volume control or right/left simultaneous volume control can be selected by DC voltages. Its built-in pass through function, in combination with an ALC amplifier, offers the capability of automatic level control.

### FEATURES

- Two control modes can be selected.  
(Left/right independent volume control mode or left/right simultaneous volume + balance control mode).
- Pass through switch is included to output the input signal as it is, irrespective of the volume/balance control voltages.
- Shock noise reduction pin is provided to reduce pass through switch on/off shock noise.
- Built-in reference supply voltage circuit  
..... output current 10mA (typ)
- Maximum input.....3.4Vrms (typ)  
(f = 1kHz, THD = 1%)
- Low distortion.....0.005% (typ)
- Good channel separation.....102dB (typ)  
(f = 1kHz, V<sub>o</sub> = 2Vrms, IHF - A)



Outline 14P5A(L)

1.27mm pitch 325mil ZIP  
(2.8mm × 19.0mm × 6.3mm)

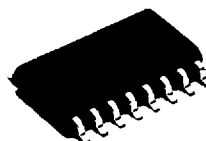

Outline 16P2N-A(FP)

1.27mm pitch 300mil SOP  
(5.3mm × 10.1mm × 1.8mm)

### RECOMMENDED OPERATING CONDITIONS

Supply voltage range.....V<sub>cc</sub> = 8 to 15V  
Rated supply voltage.....V<sub>cc</sub> = 12V

### SYSTEM CONFIGURATION

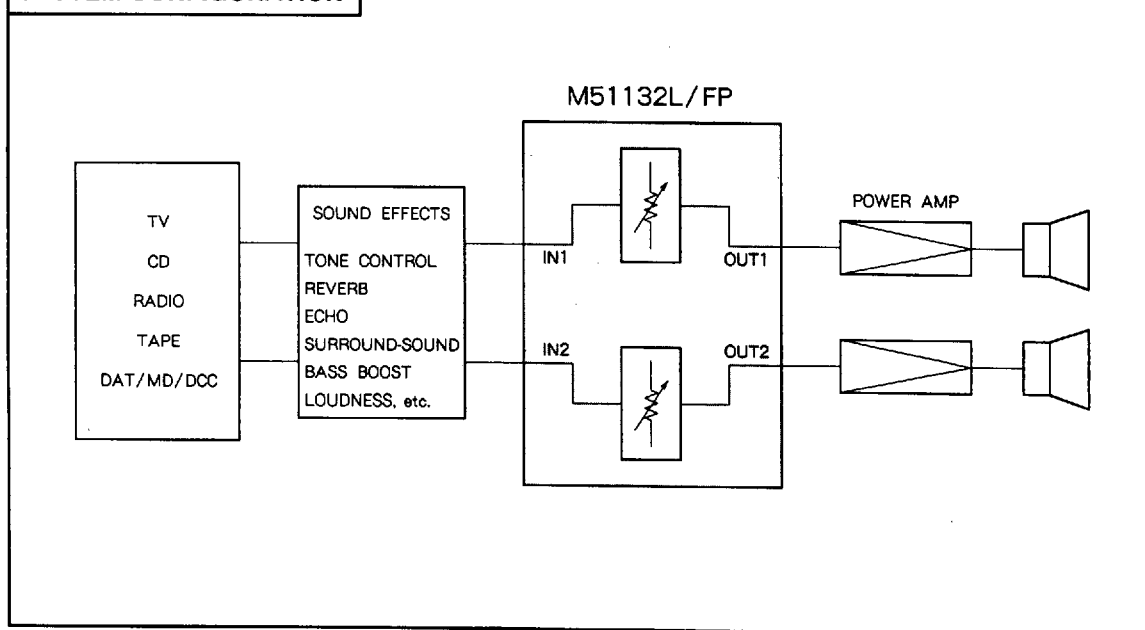

# M51132L/FP

## 2CH ELECTRONIC VOLUME-BALANCE

### PIN CONFIGURATION (TOP VIEW)

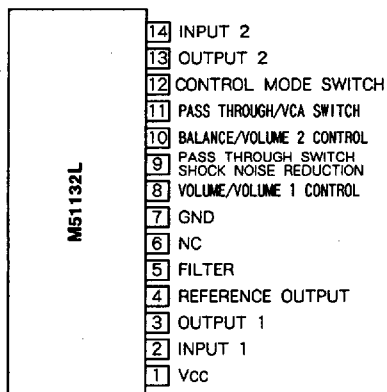

Outline 14P5A(L)

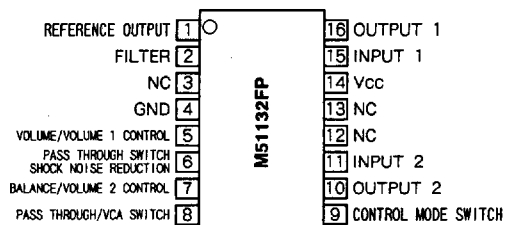

Outline 16P2N-A(FP)

NC: NO CONNECTION

### IC INTERNAL BLOCK DIAGRAM (M51132L)

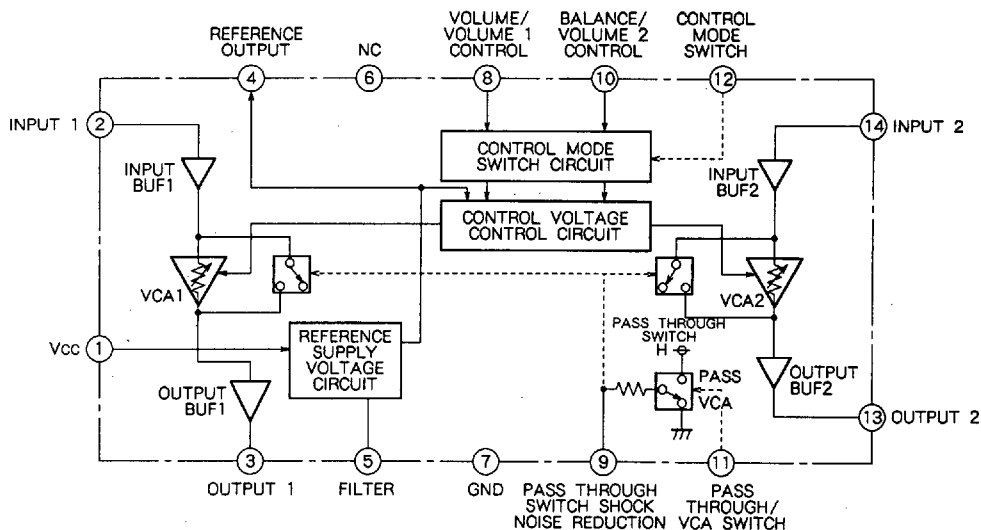

2CH ELECTRONIC VOLUME-BALANCE

PIN DESCRIPTION

Pin No.	Name	Function	Typical DC voltage
①	Vcc	DC 8 to 15V is applied (rated voltage 12V)	
②	Input 1	Maximum input 3.4Vrms (typ.)	5.5V
③	Output 1		4.8V
④	Reference supply voltage output	Maximum output current 10mA(typ.)built-in short circuit protection circuit	5.2V
⑤	Filter		12V
⑥	No connection	Can be used for wire repeater to GND, etc.	
⑦	GND		
⑧	Volume/ volume 1 control	Left/right simultaneous volume or channel 1 volume is controlled by this value in the range of 0 to 5.2V DC.	
⑨	Pass through switch shock noise reduction	Transit noise to the ear is softened by slowly switching between pass through and VCA with time constant when the pass through switch is turned on/off. The time constant is determined by externally connected capacitor. $T(\text{sec}) = 1.2 \times C \times 20k$	5.2V for pass through and 0V for VCA
⑩	Balance/ volume 2 control	Balance or channel 2 volume is controlled with 0 to 5.2V.	
⑪	Pass through/VCA switch	Operates as VCA with 0V, and passes through the input to output with 5.2V.	
⑫	Control mode switch	Operates as channel 1 volume at pin ⑧ and as channel 2 volume at pin ⑩ with 0V. Operates as channel 1 and channel 2 simultaneous volume at pin ⑧ and as balance at pin ⑩ with 5.2V.	
⑬	Output 2		4.8V
⑭	Input 2	Maximum input 3.4Vrms (typ)	5.5V

ABSOLUTE MAXIMUM RATINGS (Ta = 25°C, unless otherwise noted)

Symbol	Parameter	Conditions	Ratings	Unit
Vcc	Supply voltage	Quiescent	15.5	V
Icc	Circuit current		40	mA
Pd	Power dissipation	When mounted on PC board	800(L) / 550(FP)	mW
Ke	Thermal derating	Ta ≥ 25°C	8.0(L) / 5.5(FP)	mW/°C
Topr	Operating temperature		-20 to +75	°C
Tstg	Storage temperature		-40 to +125	°C

TYPICAL CHARACTERISTICS

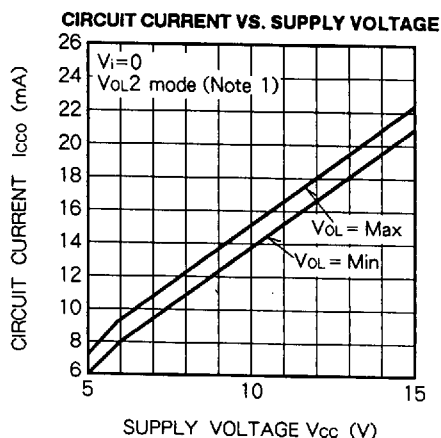
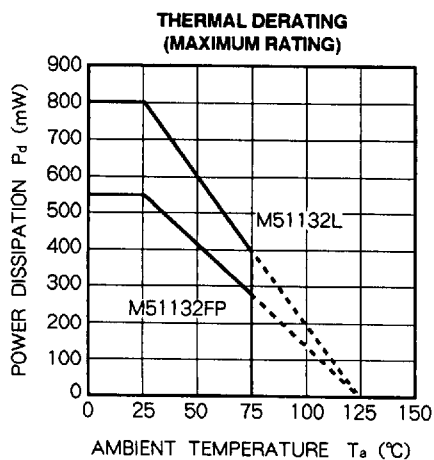

Note 1. VOL2 mode is left/right independent volume control mode.

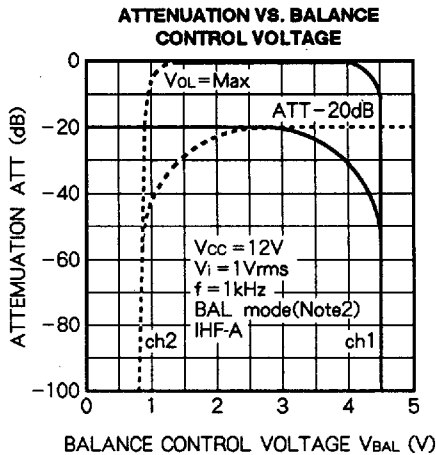
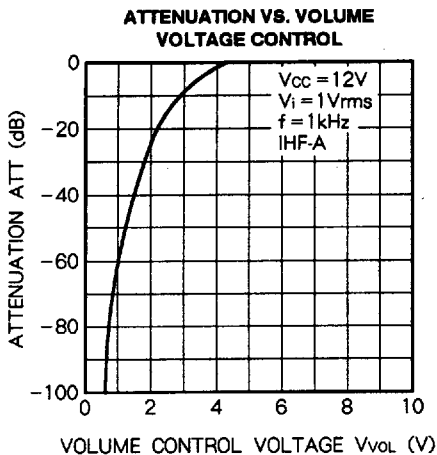

Note 2. BAL mode is left/right simultaneous volume and balance control mode.

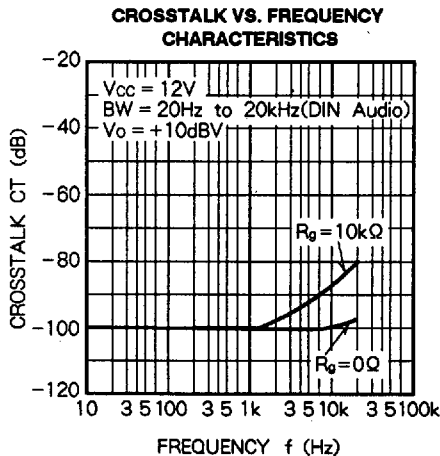
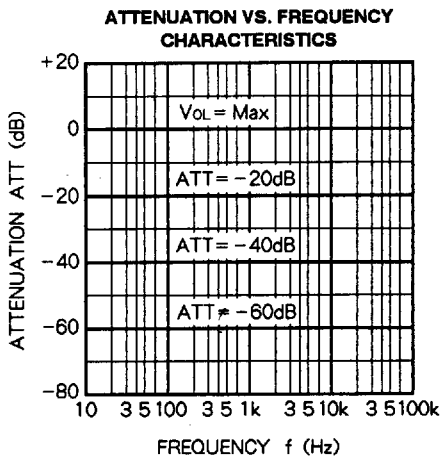
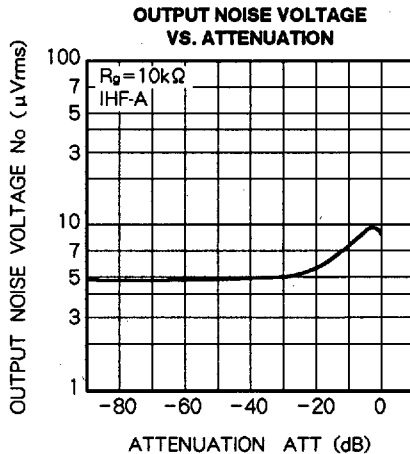
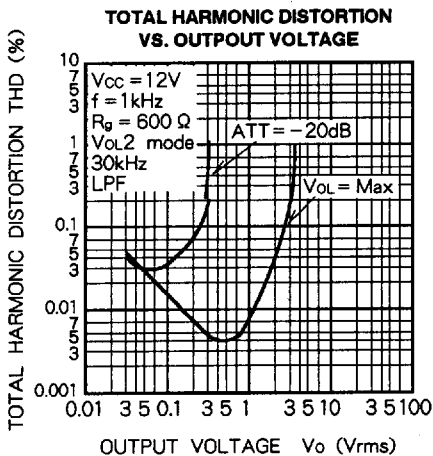

2CH ELECTRONIC VOLUME-BALANCE

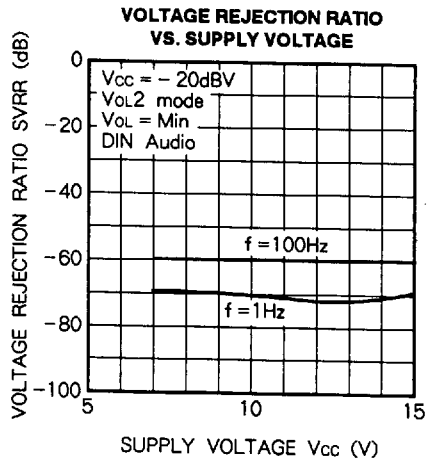
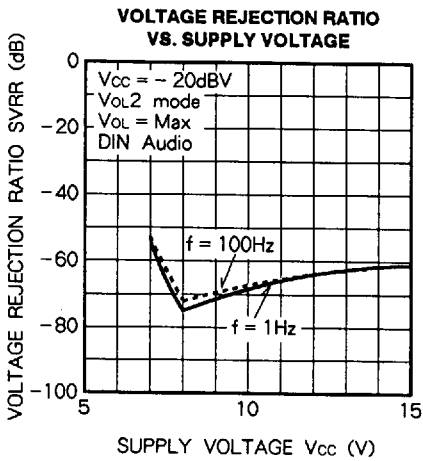
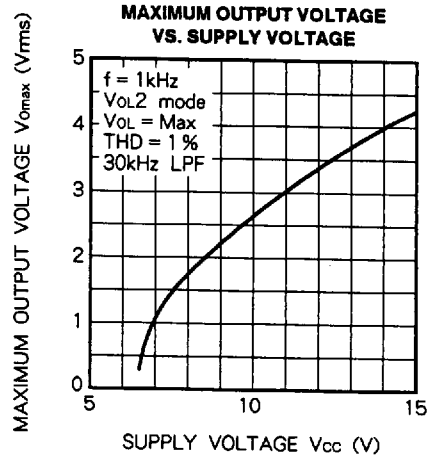
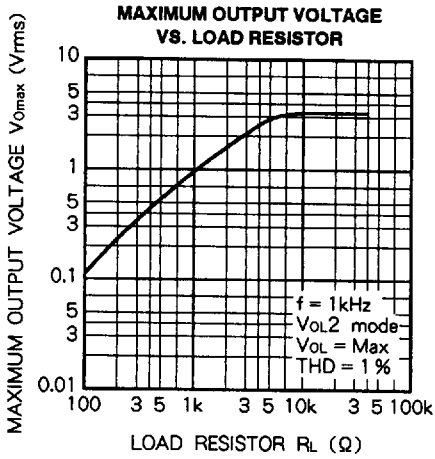

2CH ELECTRONIC VOLUME-BALANCE

ELECTRICAL CHARACTERISTICS (Ta = 25°C, Vcc = 12V, f = 1kHz, Vi = 1Vrms, Volume Max, unless otherwise noted)

Symbol	Parameter	Test conditions	Limits			Unit
			Min	Typ	Max	
Icco	Circuit current	In quiescent state, volume : min	9	17	30	mA
ATT <sub>0</sub>	Attenuation		-2	0	+2	dB
Att-∞		Vi = 2Vrms, IHF-A, volume : min		-105	-85	dB
CB	Channel balance		-2	0	+2	dB
THD	Total harmonic distortion	15kHz, LPF		0.01	0.1	%
Ri	Input resistor		5.0	150		kΩ
BAL	Balance attenuation	Vi = 2Vrms, IHF-A		-105	-85	dB
N <sub>Omin</sub>	Output noise voltage	R <sub>G</sub> =10kΩ, in quiescent state, IHF-A, volume:min		4.8	10	μVrms
N <sub>Omax</sub>		R <sub>G</sub> =10kΩ, in quiescent, IHF-A		9	20	μVrms
V <sub>imax</sub>	Maximum input voltage	THD = 1%, volume : center	2	3.4		Vrms
V <sub>Omax</sub>	Maximum output voltage	THD = 1%	2	3.4		Vrms
C <sub>T</sub>	Crosstalk	R <sub>G</sub> = 0Ω, Vi = 2Vrms, IHF-A		-102	-80	dB
G <sub>VP</sub>	Pass through voltage gain	Volume : min	-1.2	+0.8	+2.8	dB
C <sub>BP</sub>	Pass through channel balance	Volume : min	-2	0	+2	dB

- Note 3. The volume max is the condition in which the same voltage as Vr is applied to pin ⑧.  
 4. The volume center is the condition in which the same voltage as Vr/2 is applied to pin ⑧.  
 5. The volume min is the condition in which pin ⑧ is connected to GND.

I/O INTERFACE (M51132L)

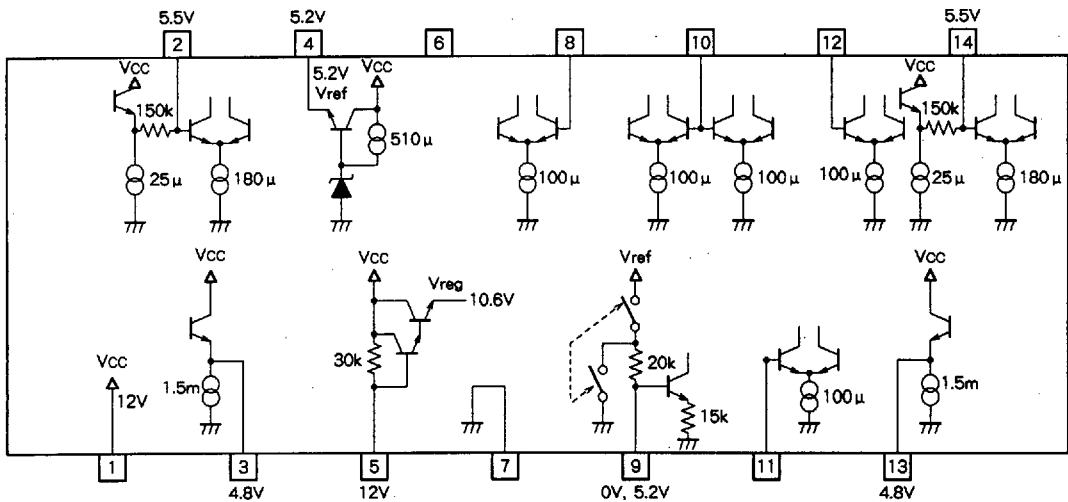

Note 6. All resistors, voltages, currents are shown in typical values.

Units Resistance : Ω  
 Voltage : V  
 Current : A

# M51132L/FP

## 2CH ELECTRONIC VOLUME-BALANCE

### TEST CIRCUIT (M51132L)

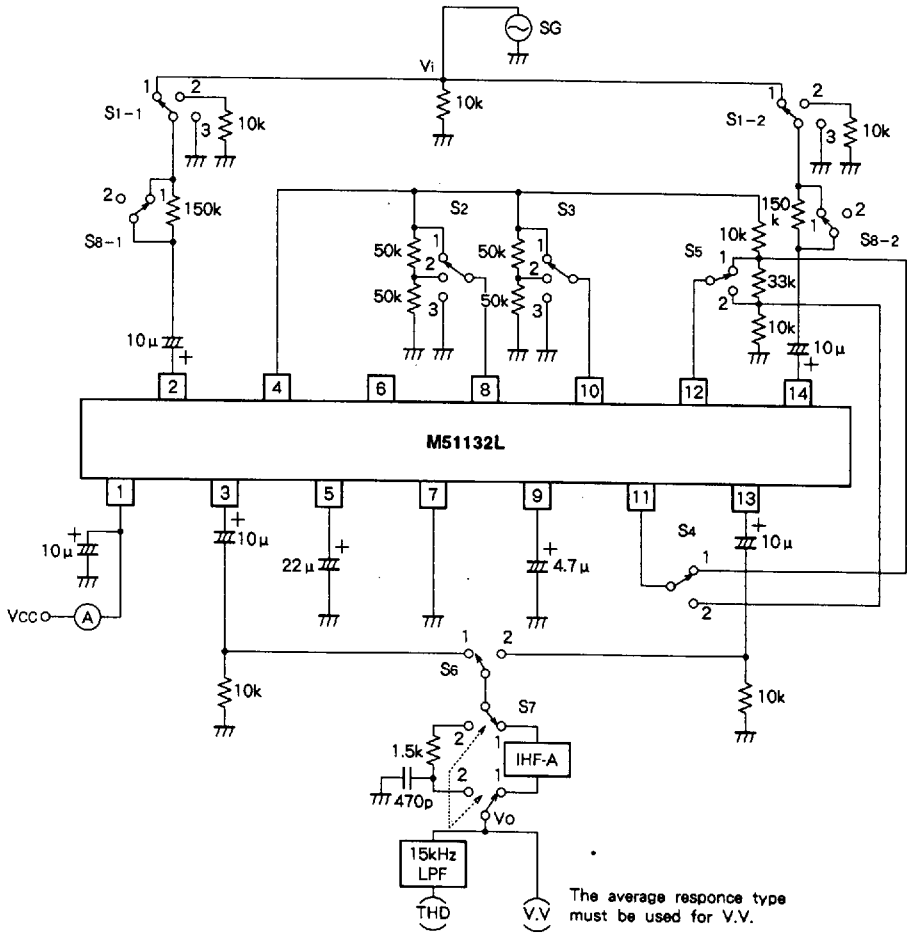

The average response type must be used for V.V.

The IHF-A filter can be replaced with the following circuit.  
 Example of IHF-A filter equivalent circuit (Note that the output is multiplied by 100).

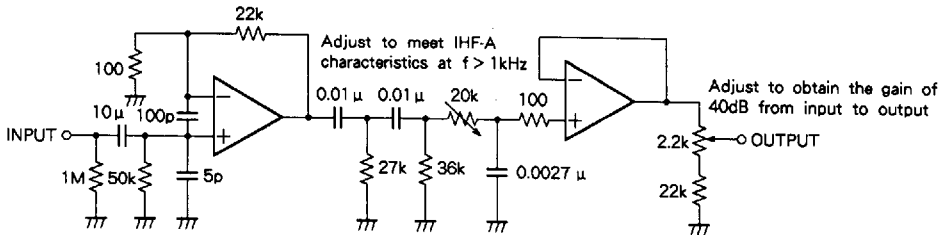

Units Resistance : Ω  
 Capacitance : F

SWITCH CONDITION AND TEST METHOD

Symbol	Parameter	Switch										Test method
		S <sub>1-1</sub>	S <sub>1-2</sub>	S <sub>2</sub>	S <sub>3</sub>	S <sub>4</sub>	S <sub>5</sub>	S <sub>6</sub>	S <sub>7</sub>	S <sub>8-1</sub>	S <sub>8-2</sub>	
I <sub>cco</sub>	Circuit current	2	2	3	3	2	2	1	2	1	1	Measure the current flowing to pin ① in quiescent state
ATT <sub>0</sub>	Attenuation	1	1	1	$\frac{1}{2}$	2	$\frac{2}{1}$	1/2	2	1	1	Obtain from the equation ATT(dB) = 20 log(V <sub>o</sub> /V <sub>i</sub> ) ATT-∞ is IHF-A in
Att-∞		1	1	3	$\frac{3}{2}$	2	$\frac{2}{1}$	1/2	1	1	1	
CB	Channel balance	1	1	1	$\frac{1}{2}$	2	$\frac{2}{1}$	1→2	2	1	1	CB(dB) = ATT <sub>ch1</sub> - ATT <sub>ch2</sub>
THD	Total harmonic distortion	1	1	1	$\frac{1}{2}$	2	$\frac{2}{1}$	1/2	2	1	1	15kHz LPF in
R <sub>i</sub>	Input resistor	1	1	1	1	2	2	$\frac{1}{2}$	2	1→2	1→2	Given the output as V <sub>o1</sub> when S <sub>8</sub> →1 and the output as V <sub>o2</sub> when S <sub>8</sub> →2 R <sub>i</sub> (kΩ) = 150/(V <sub>o1</sub> /V <sub>o2</sub> - 1)
BAL	Balance attenuation	1	1	1	$\frac{1}{3}$	2	1	$\frac{1}{2}$	1	1	1	BAL(dB) = 20 log(V <sub>o</sub> /V <sub>i</sub> )
N <sub>omin</sub>	Output noise voltage	2	2	3	$\frac{3}{2}$	2	$\frac{2}{1}$	1/2	1	1	1	IHF-A in
N <sub>omax</sub>		2	2	1	$\frac{1}{2}$	2	$\frac{2}{1}$	1/2	1	1	1	IHF-A in
V <sub>imax</sub>	Maximum input voltage	1	1	2	2	2	$\frac{2}{1}$	1/2	2	1	1	Input signal voltage when the output distortion rate is 1%.
V <sub>omax</sub>	Maximum output voltage	1	1	1	$\frac{1}{2}$	2	$\frac{2}{1}$	1/2	2	1	1	Output signal voltage when the output distortion rate is 1%.
C <sub>T</sub>	Crosstalk	3	1	1	1	2	2	1	1	1	1	IHF-A in C <sub>T</sub> (dB) = 20 log (V <sub>o</sub> (V <sub>rms</sub> )/2(V <sub>rms</sub> ))
		1	3					2				
G <sub>VP</sub>	Pass through voltage gain	1	1	3	3	1	2	1/2	2	1	1	G <sub>VP</sub> (dB) = 20 log(V <sub>o</sub> /V <sub>i</sub> )
C <sub>BP</sub>	Pass through channel balance	1	1	3	3	1	2	1→2	2	1	1	C <sub>BP</sub> (dB) = G <sub>Vpch1</sub> - G <sub>Vpch2</sub>

Note 7. If the parameter is separated into two rows, All the switching conditions in the upper row and all the switching conditions in the lower row are measured.



APPLICATION EXAMPLES (M51132L)

(a) Control by left/right simultaneous variable volume and balancer

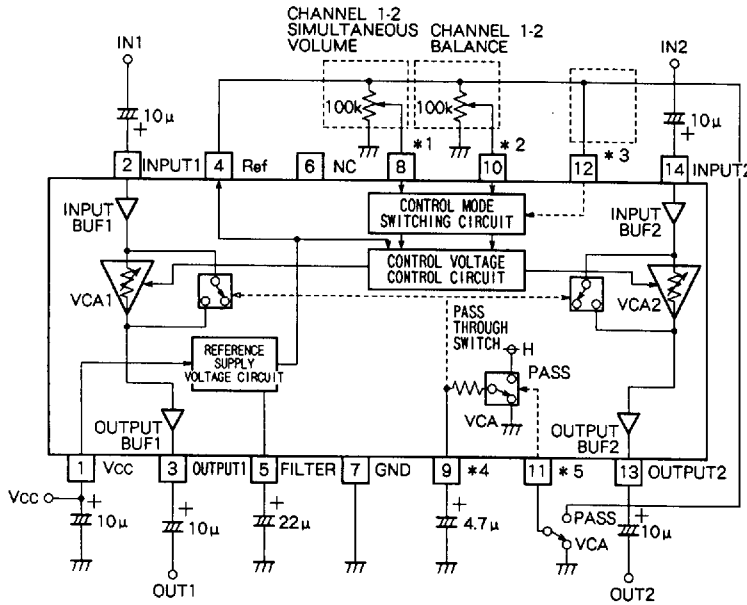

- \* 1 Volume/volume 1 control
- \* 2 Balance/volume 2 control
- \* 3 Control mode switch
- \* 4 Pass through switch shock noise reduction
- \* 5 Pass through/VCA switch

(b) Control by left/right independent volume

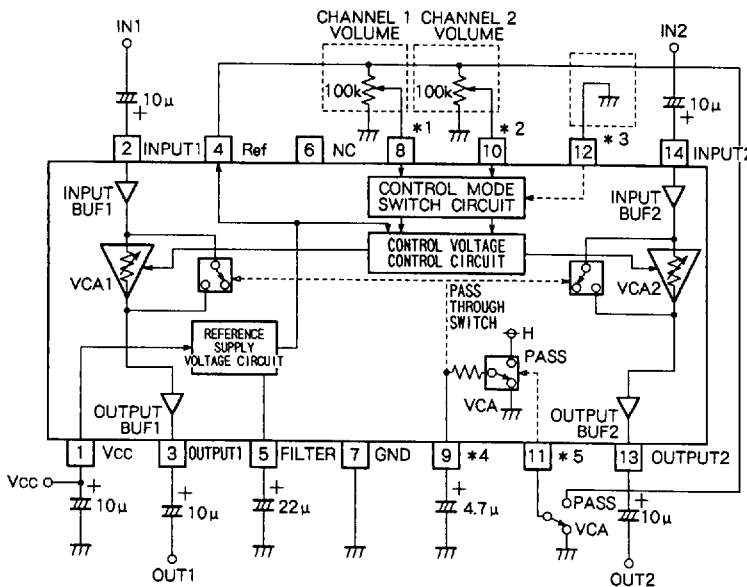

- \* 1 Volume/volume 1 control
- \* 2 Balance/volume 2 control
- \* 3 Control mode switch
- \* 4 Pass through switch shock noise reduction
- \* 5 Pass through/VCA switch

Different between example (a) and (b)

Pin No.	Example (a)	Example (b)
⑧	Volume control	ch1 volume control
⑩	Balance control	ch2 volume control
⑫	Connected to pin ④	GND

Units Resistance : Ω  
Capacitance : F