



elektor electronics

Multi Programmer on USB

Cool audio power:
Class T

Have MS Word,
will program

DAB:
ten years after

www.elektor-electronics.co.uk

June 2004 • £3.70



9 770268 451111

PAGM

The leaders in PIC development

FROM

£99



EASE OF USE



AUTOMATION



SCRIPTABILITY

- ◆ All you need to get started with PIC
- ◆ Industry standard/quality board
- ◆ Open the box and get coding
- ◆ Available with C compiler or use our PicScript to write programs using simple commands...

**NO ASSEMBLER,
NO COMPILER,
JUST WRITE AND RUN**

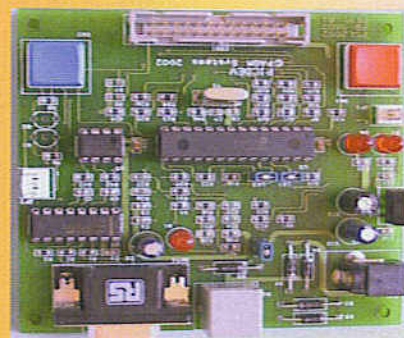

PicDev Board with PicScript

£99.00 (plus p+p)

This is a complete development suite for the novice or non programmer.

It is shipped with:

- PicDev Board
- PicShell and PicScript software
- Breakout board
- Cables
- Example scripts

PicDev Board with C Compiler

£165.00 (plus p+p)

This is a complete development suite for the more advanced programmer.

It is shipped with:

- PicDev Board
- PicShell and PicScript software
- C compiler
- Breakout board
- Cables
- Example scripts
- ICD1

Both items require

- PC with serial port available
- Power supply adapter

To order:

www.pagm.co.uk

sales@pagm.co.uk

Tel: +44 (0)1792 891927

OUR WIRELESS FUTURE

Few readers will doubt that our future will be 'wireless' in many respects. Just look at the tremendous success of mobile telephones — the younger generation would not have a social life without these gizmos. Meanwhile the UMTS licenses that allow much faster Internet-like connections have been auctioned off for immense sums and the nets are rolled out for practical use. Unexpected competition however has appeared in the form of WLANs (wireless local area networks) or 'wi-fi' networks not only available in many a home and company building but also increasingly found in public buildings where they go by the name of 'hotspots'. The main advantage of hotspots is their low cost structure and much higher data speeds than the current UMTS offerings. On the down side, the available range is limited to a few tens of meters. Hence WLAN has no use in cars, where, come to think of it, mobile phones or UMTS is not much use either unless you are the passenger, want to risk a fine or far more grim consequences. When WLAN marches on, the billions spent on UMTS licenses are wasted and the odd telecom provider is sure to fold. As always, the outcome of a technology battle will be determined by reality rather than (technical) bells and whistles. GSM/UMTS activities require telephone-like devices small enough to disappear in your trouser pocket or be carried around all day and quietly forgotten about. WLAN is more geared to notebook or tablet PCs. Alas, no news from the tablet PC and no signs either of an imminent breakthrough. My prediction is that today's mobile phone will become so small it easily fits in your wristwatch. Also, what's now recognized as a notebook PC will transform into a collapsible touchscreen. Both, I am convinced, will have open wireless connectivity. Whether the connection will be to hotspots or UMTS (or even HSPDA) will eventually depend on ease of use and running costs. Prediction means making lines from the past longer. You can see me pictured before a prehistoric flint quarry. Spectacular developments have taken place since the days our ancestors were first able to make sharp tools from flint. Flint, by the way, consists of silicon dioxide. Now what was the stuff again all modern ICs and transistors are made of?

Karel Walraven, Head of Design



elektor electronics

Volume 30, Number 333, June 2004

ISSN 0268/4519

Elektor Electronics aims at inspiring people to master electronics at any personal level by presenting construction projects and spotting developments in electronics and information technology.

Elektor Electronics is produced and published by Elektor Electronics (Publishing), P.O. Box 190, Tunbridge Wells TN5 7WY, England. Tel.: (+44) (0)1580 200657, fax: (+44) (0)1580 200616. Email: sales@elektor-electronics.co.uk.

The magazine is available from newsagents, bookshops and electronics retail outlets, or on subscription.

Elektor Electronics is published 11 times a year with a double issue for July & August.

Under the name *Elektor* and *Elektuur*, the magazine is also published in French, German and Dutch. Together with franchised editions the magazine is on circulation in more than 50 countries.

International Editor (ad interim): Han Mensink

Editor: Jan Buiting (editor@elektor-electronics.co.uk)

International editorial staff: Harry Baggen, David Daamen, Rolf Gerstendorf, Ernst Krempelsauer, Guy Raedersdorf, Sijf van Rooij.

Design staff: Karel Walraven (head of design), Ton Giesberts, Paul Goossens, Luc Lemmens (techdept@segment.nl)

Editorial secretariat: Hedwig Hennekens (secretariaat@segment.nl)

Graphic design / DTP: Ton Gulikers, Giel Dols

Managing Director / Publisher: Paul Snackers

Circulation Control: Margriet Debeij (m.debeij@segment.nl)

Subscriptions

Worldwide Subscription Service Ltd., Unit 4, Gibbs Reed Farm, Pashley Road, Ticehurst TN5 7HE, England. Telephone: (+44) (0)1580 200657, Fax: (+44) (0)1580 200616. Email: wwss@wwss.demon.co.uk. Rates and terms are given on the Subscription Order Form

Head Office:

Segment b.v. P.O. Box 75 NL-6190-AB Beek The Netherlands. Telephone: (+31) 46 4389444, Fax: (+31) 46 4370161

Distribution: Seymour, 86 Newman Street, London W1P 3LD, England

UK Advertising

Bernard Hubbard, 3 Crescent Terrace, Cheltenham GL50 3PE, England. Telephone (+44) (0)1242 510760, Fax: (+44) (0)1242 226626. Email: bernardhubbard@ukonline.co.uk. Advertising rates and terms available on request.

International Advertising

K. Caldenhoven, address as Head Office. Email: advertenties@elektuur.nl. Advertising rates and terms available on request.

Copyright notice

The circuits described in this magazine are for domestic use only. All drawings, photographs, printed circuit board layouts and article texts published in the editorial section of the magazine are copyright Segment. b.v. and may not be reproduced or transmitted in any form or by any means, including photocopying, scanning or recording, in whole or in part without prior written permission from the Publishers. Such written permission must also be obtained before any part of this publication is stored in a retrieval system of any nature.

Patent protection may exist in respect of circuits, devices, components etc. described in this magazine. The Publisher does not accept responsibility for failing to identify such patent(s) or other protection.

The submission of designs or articles implies permission to the Publishers to alter the text and design, and to use the contents in other Segment publications and activities. The Publishers cannot guarantee to return any material submitted to them.

© Segment b.v. 2004

Printed in the Netherlands



leading the way

44

Ten Years After

DAB in Europe

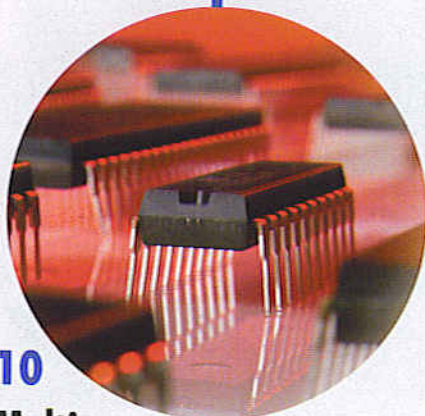
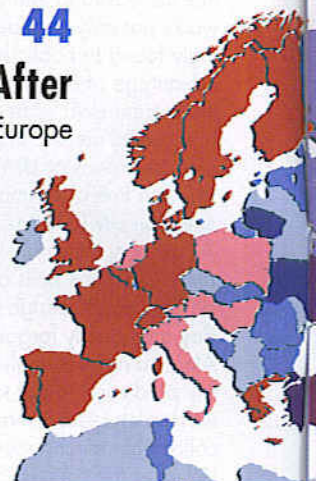

10

Multi Programmer

For controllers and EEPROMs

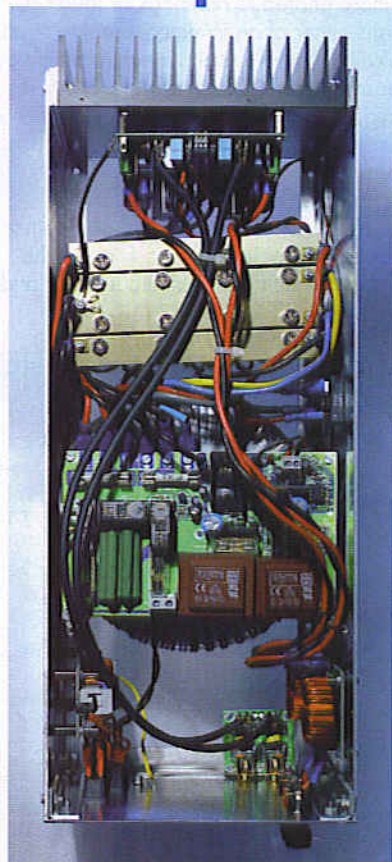

24

ClariTy

A 2x300-W class-T amplifier

50

Pocket Pong

A TV game without a TV

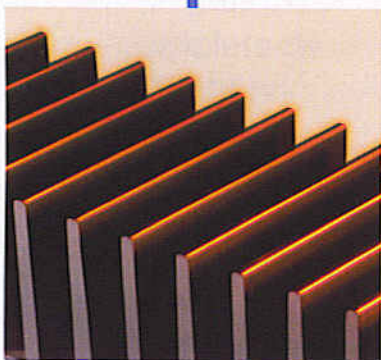

18

That's Class...

Audio amps from A through T

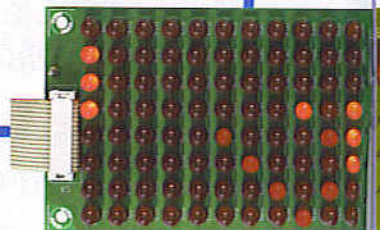

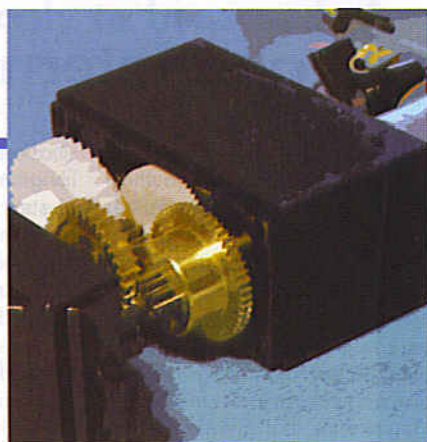

62

Digital Motors

Enter the digital servo

64

Rail Router

Model train control
with a PC

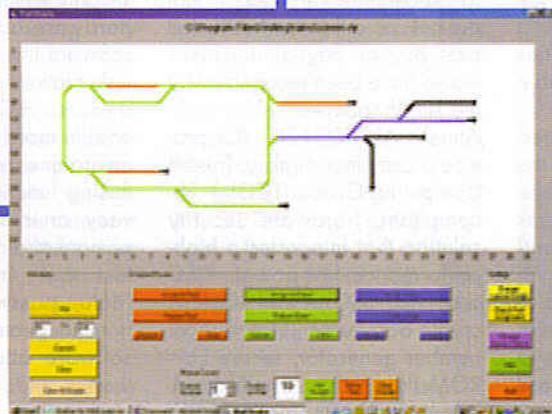

Construction Projects

- 10 Multi Programmer
- 24 ClariTy
2 x 300 W Class-T Amplifier
- 38 Smooth Operator
- 50 Pocket Pong
- 58 kitchen table
Personal Sound to light Unit
- 64 Rail Router

Informative Articles

- 18 That's Class...
- 32 Design your Own IC (2)
- 44 Ten Years After
- 54 review copy
Free PICProg — Analog University
- 56 start here
Precision Function Generator
- 62 inside out
Digital Motors
- 69 Programming with Word

Regulars

- 3 Foreword & Colophon
- 6 News & New Products
- 72 Mailbox
- 77 Readers Services
- 81 PCB Layouts
- 82 Sneak Preview
- 82 Index of Advertisers

HARDWARE FOR TRUSTED SOURCE RECOGNITION

Atmel chips thwart viruses and Internet fraud

Atmel® Corporation's Trusted Platform Module (TPM) ICs could help prevent identity theft, such as those perpetrated on Best Buy™ and PayPal® customers last summer, as well as viruses and worms, such as MyDoom, Sobig.F and Blaster.

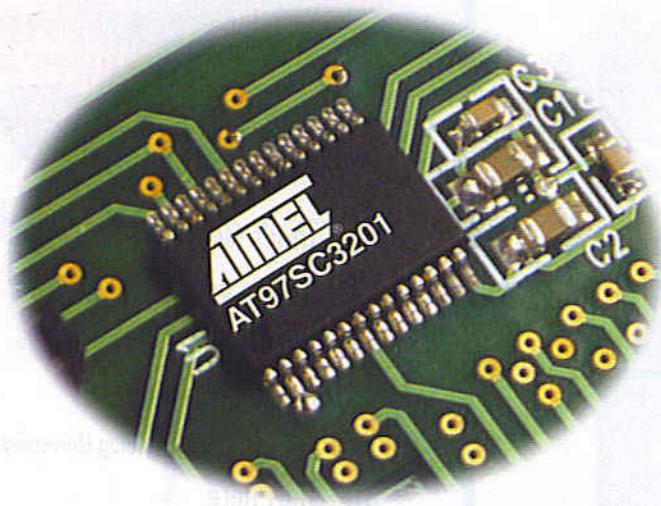

In just one week, Blaster infected 500,000 computers and caused an estimated \$1.3 billion in financial losses. The recent MyDoom virus is reported to be the fastest spreading ever, infecting one in 12 PCs. Atmel's TPM chips provide secure hardware-based, storage and management of the user's identity, passwords, and encryption keys, unlike most software-only security solutions.

According to Kerry Maletsky, Business Unit Director, North American ASIC/ASSP products at Atmel, "The real issue with viruses, worms and other Internet crime is identity. Can the identity of the data sender be reliably authenticated? Can the user or operating system determine that a program is safe to run, prior to its execution? With trusted computing platforms, the answer to both questions is yes

because the authentication and integrity of both the programs and machines can be absolutely verified. The only way to cheat the system would be to copy the contents of the TPM or physically remove the chip and put it in another system — activities that cause the chip to disable the system.

"The concept of authenticated identity can be extended to the BIOS, operating system and the catalog of registered programs to protect from worms and viruses such as MyDoom, Sobig.F or Blaster. In this context, registration is the process by which software is measured and said measurements are stored in a catalogue of known measurements. Worms and viruses are computer programs," Maletsky explained. "If a computer's BIOS and OS only allow execution of programs whose measurements match the values

found in the measurement catalogue protected by and authenticated by the TPM neither worms nor viruses could ever execute. Since the catalogue of program measurement data is protected by the TPM IC, hackers could not alter it and go undetected. This capability could be particularly useful in preventing worms that invade servers through security holes and are difficult to detect until they have done a lot of damage. Unlike anti-virus software that can only be available after the virus has done some damage, TPMs offer the potential to prevent the outbreak before it happens.

"TPMs can help prevent phishing and spoofing scams as well," Maletsky continued. "Last summer's Best Buy and PayPal Internet scams used "spoofed" emails to elicit sensitive financial information from victims. Since TPM ICs can be used to ensure that emails are accepted only from "authenticated" sources, including identification of the actual hardware generating the email, they could have prevented these crimes. If Best Buy, PayPal and the victims had used Atmel TPM enabled computers and servers, the thieves could have been foiled because the "spoofs" that did not come from authenticated Best Buy or PayPal machines would have been recognized by the TPM hardware."

Atmel's AT97SC3201 ICs provide a complete, turnkey, Trusted Computing Group (TCG) 1.1b-compliant, hardware security solution that integrates a high-performance low-power, RISC processor, 500 ms 2048-bit RSA crypto accelerator, true random number generator, secure EEPROM storage for 20 public/private keys, SRAM, timer, real-time clock, LPC interface to Intel processors, and tamper prevention circuitry that disables the chip if someone tries to read its contents. Atmel's TPMs have unique, inaccessible ID codes

that are used to authenticate the origination of data sent from the system. Atmel's TPMs include drivers for Windows 98, 2 K, XP, and NT 4.0 operating systems; as well as MAD and MPD BIOS drivers.

In addition to PCs, the Atmel TPM is also finding its way into embedded applications such as PDAs, cell phones, POS terminals and set top boxes to secure content as well as sensitive eCommerce applications.

Atmel's AT97SC3201 TPM ICs are part of a family of products known as SiliconCITY™. Atmel's SiliconCITY products are based on re-useable and validated intellectual property and architectures from Atmel's broad line of standard products, ASSPs and system-on-chip portfolio. Atmel's AT97SC3201 TPMs that comply with TCG Standard 1.1b are available now, and are priced to OEMs at \$4.00 in volume.

Trusted Computing Group

(TCG) is an open, industry standards organization formed to develop, define, and promote open standards for hardware-enabled trusted computing and security technologies, including hardware building blocks and software interfaces, across multiple platforms, peripherals, and devices. TCG specifications enable more secure computing environments without compromising functional integrity, privacy, or individual rights. The primary goal is to help users protect their information assets (data, passwords, keys, etc.) from compromise due to external software attack and physical theft.

www.trustedcomputinggroup.org,
www.atmel.com/products/Embedded/

(047073-1)

A power supply to be proud of

Lascar Electronics have broken the mould with the PSU 130 — a compact, aesthetically designed power supply that will soon become commonplace in Workshops and Engineering Departments everywhere.

The PSU 130 is a bench-top power supply with an adjustable output from 1.5 to 30 Volts at up to 1 Amp. The output voltage can be accurately adjusted to within 0.1 Volts across its entire range. The selected voltage and current drawn are clearly displayed on the PSU 130's large backlit LCD. The PSU 130 features over-voltage, over-current and short-circuit protection, preventing accidental damage to the unit. The

output terminals are standard 4-mm sockets on a 19-mm pitch. With a compact, non-slip, footprint of only 135mm x 140mm, bench space can be maximised. The PSU 130 can also be angled to suit varying operating environments.

The PSU 130 is available immediately from Lascar Electronics Ltd. at a price of £49.85 + VAT. Discount is available for volume orders.

**Lascar Electronics Limited, Module
Hose, Whiteparish, Salisbury, Wiltshire
SP5 2SJ. Tel. (+44) (0)1794
884567, Fax (+44) (0)1794 884616.
Internet: www.lascarelectronics.com**

(047076-1)



Low-power low-dropout regulator

Microchip's new Low Dropout Regulator (LDO), is stable with ceramic capacitors and operates at a very low supply current. Attachable to practically any microcontroller, this device is a low-cost, low-power LDO ideal for virtually any portable or battery-powered application.

Microchip's MCP1700 LDO can deliver up to 250 milliamps of current while consuming only 1.6 microamps of quiescent current (typical). This device maximizes battery life with a dropout voltage of 178 millivolts at 250 milliamps; increases performance with an output voltage accuracy of ± 0.4 percent and exceeds in dynamic behaviour with better line (± 0.75 percent V) and load (± 1.0 percent V) regulation.

The MCP1700 enables the use of low-cost ceramic capacitors on the input and output, which reduces the system cost. This LDO is stable with 1-microfarad (μF) output capacitor; meanwhile, its overcurrent limit and overtemperature shutdown pro-

vides a robust solution for any application.

The device is claimed to offer the use of low cost ceramic capacitors, low supply current, tighter output-voltage tolerance, lower dropout at rated current and tighter specifications across the range. This gives designers an LDO that helps reduce costs and increase battery life, and allows the application to operate at a lower input voltage.

Attachable to virtually any microcontroller, including Microchip's PIC[®] microcontroller family, this device is available in 3-pin, SOT 23, SOT 89 and TO 92 packages. Pricing in 10,000-unit quantities is \$0.39 USD each. Samples and volume production are available now.

**Arizona Microchip Technology Ltd.,
Microchip House, 505 Ekdale Road,
Winersh Triangle, Wokingham RG41
5TU. Tel. (+44) (0)118 921 5858.
Fax (+44) (0)118 921 5835.
www.microchip.com.**

(047076-2)



**elektor
electronics**

Books from elektor electronics



308 Circuits
Summer Circuits compilation
2000, 2001, 2002
£ 18.20/US\$ 37.00

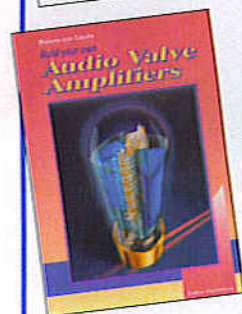

**Build your own
Audio Valve Amplifiers**
This book proves that the thermionic
valve is making a come-back.
£ 15.55/US\$ 31.00

Short Course 8051/8032 Microcontrollers

A course describing the hardware and
software (assembler code) to make
a complete microcontroller system
based on an MCS-51 controller.
£ 9.95/US\$ 20.00

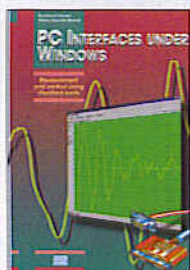

PC Interfaces under Windows
Measurement and control using
standard ports PC Interfaces can be
used for more than just the printer,
mouse, modem and joystick!
£ 25.95/US\$ 52.00



Faultfinding in Computers and Digital Circuits

This book covers faultfinding
not just in microprocessor
systems, microcontrollers
and industrial PCs, but also
in consumer items such
as personal computers,
multi-media devices, digital
television and so on.
£ 31.15/US\$ 63.00

Order now using the Order Form
in the Readers Services section in this issue.

Elektor Electronics (Publishing)

P.O. Box 190 – Tunbridge Wells TN5 7WY England

Telephone +44 (0) 1580 200 657 Fax +44 (0) 1580 200 616

302 Circuits
Summer Circuits
compilation
1982, 1983, 1984
£ 10.35/US\$ 21.00

304 Circuits
1988, 1989, 1990
£ 13.45/US\$ 27.00

305 Circuits
1991, 1992, 1993
£ 15.55/US\$ 31.00

307 Circuits
1997, 1998, 1999
£ 18.20/US\$ 37.00

Electronics



Build your own Electronic Test Instruments

For good reasons
(cost, challenge) many
researchers, enthusiasts,
and experimenters like
to build test instruments
themselves.
£ 16.60/US\$ 33.00

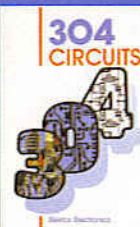

Build your own Electronic test Instruments



Lasers: Theory and Practice

A valuable book
on the practical use
of lasers.
£ 20.75/US\$ 42.00



LASERS: THEORY AND PRACTICE



Audio & Video

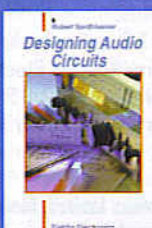

Designing Audio Circuits

How does speech,
music, or, indeed,
any sound get from
the record, CD, or
cassette tape to the
loudspeaker? This book
endeavours to give a
comprehensible answer.
£ 20.75/US\$ 42.00



Handbook for Sound Technicians

A book on the
technical aspects of
the recording studio.
£ 20.75/US\$ 42.00



Build your own High-End Audio Equipment

For those who cannot
pay high prices for
high end equipment,
a solution offered in
this book: build your
own at considerable
cost savings.
£ 15.55/US\$ 31.00



Modern High-End Valve Amplifiers

Valve amplifiers based
on toroidal output trans-
formers combine of
classical technology and
modern components.
The result: excellent
sonic quality and a
revival of the valve
amplifier.
£ 25.95/US\$ 52.00

Microcontrollers



Matchbox Basic Computer

This book describes a miniature
controller system using a
programming language called
MBL (MatchBox language), which
has its origins in BASIC and Pascal.
£ 25.95/US\$ 52.00



ST62 Microcontroller

Practical programming
of the ST62 series of
microcontrollers from
SGS-Thomson.
£ 24.95/US\$ 50.00



PICs in Practice

The PIC16C5x family is
a series of micro-
controllers that lend
themselves to a broad
variety of applications.
£ 24.95/US\$ 50.00

Computers



Dictionary of Monitor Technology

A pioneering book of unsurpassed
range which clearly documents all
aspects of the development of
computer monitors. £ 25.95/US\$ 52.00

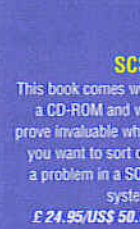

SCSI The Ins and Outs

This book comes with
a CD-ROM and will
prove invaluable when
you want to sort out
a problem in a SCSI
system.
£ 24.95/US\$ 50.00



PC Service and Repair

This book provides the information you
need to be able to deal with computer
system faults whenever they occur.
£ 31.15/US\$ 63.00

See also www.elektor-electronics.co.uk

Handyscope HS3 2 ch

Resolution Menu - 12, 14 or 16bits
Sample Rates - 5,10,25,50,100 Ms/s models



- ✓ Oscilloscope
- ✓ Spectrum Analyzer
- ✓ Voltmeter plus!
- ✓ Transient Recorder
- ✓ Arbitrary Waveform Gen.
- ✓ Two hi-z probes 1:1~1:10
- ✓ USB 1.1 or 2.0
- ✓ Windows OS- all

5 Ms/s Model
£435
ex VAT/pp

iTp Ltd

28 Stephenson Road, Industrial Estate, St Ives, Cambs. PE27 3WJ
Telephone: 01480 300695 Fax: 01480 461654

info@itp101.com www.itp101.com www.tiepie.com

PCB-POOL®

SERVICING YOUR COMPLETE PROTOTYPE NEEDS

- Prototypes at a fraction of the cost
- Industry standard quality
- Tooling and setup included
- Follow up series runs
- Any contour
- CAM / CAD consulting
- Fr4 1.6mm, 35µm Cu

PRICE EXAMPLE:
1 EUROCARD DEPTH
+ Tooling
+ Photoplots
+ VAT
= **£ 29.89***

*Sterling rates may vary. Price = €49

€49



may differ slightly to model shown

Info: +353 (0)141 701170
Fax: +353 (0)141 701164
E-Mail: sales@proto-layout.com

Freephone
0800-389 8560

Simply send your files and order ONLINE:

WWW.PCB-POOL.COM

VAROET Protel orcad GraphiCode PROTEUS Electronics

A QUANTUM LEAP IN EMBEDDED CONTROLLERS

Quick FIRE

SUPERCONTROLLERS

Our range provides:-

- The fastest 68000 based Core up to 66 Mhz.
- Extensive I/O:- Serial, IrDA, SPI, I²C, Analogue, Timers/Counters, RTC, etc.
- Large Memory Capacity:- Flash, SRAM, DRAM.
- Supports:- Mono & Colour LCD's, Touch Panels & Keypads, Very Low Power.

ALSO LOW COST

DEVELOPMENT

- Target easily & quickly.
- Full ANSI 'C' compiler, assembler & linker all Windows32 based.
- Source Level Debug.
- Full Driver Support with Libraries.
- Real Time Multitasking OS with a free run time licence.
- FREE Unlimited email support.

www.cms.uk.com

see our web site for full details

CAMBRIDGE MICROPROCESSOR SYSTEMS LTD



Unit 17-18 Zone 'D' Chelmsford Rd. Ind. Est.
Great Dunmow, Essex CM6 1XG

Telephone: **01371 875644**
email: sales@cms.uk.com

Multi Programmer

one size fits all

Andreas Oyrer

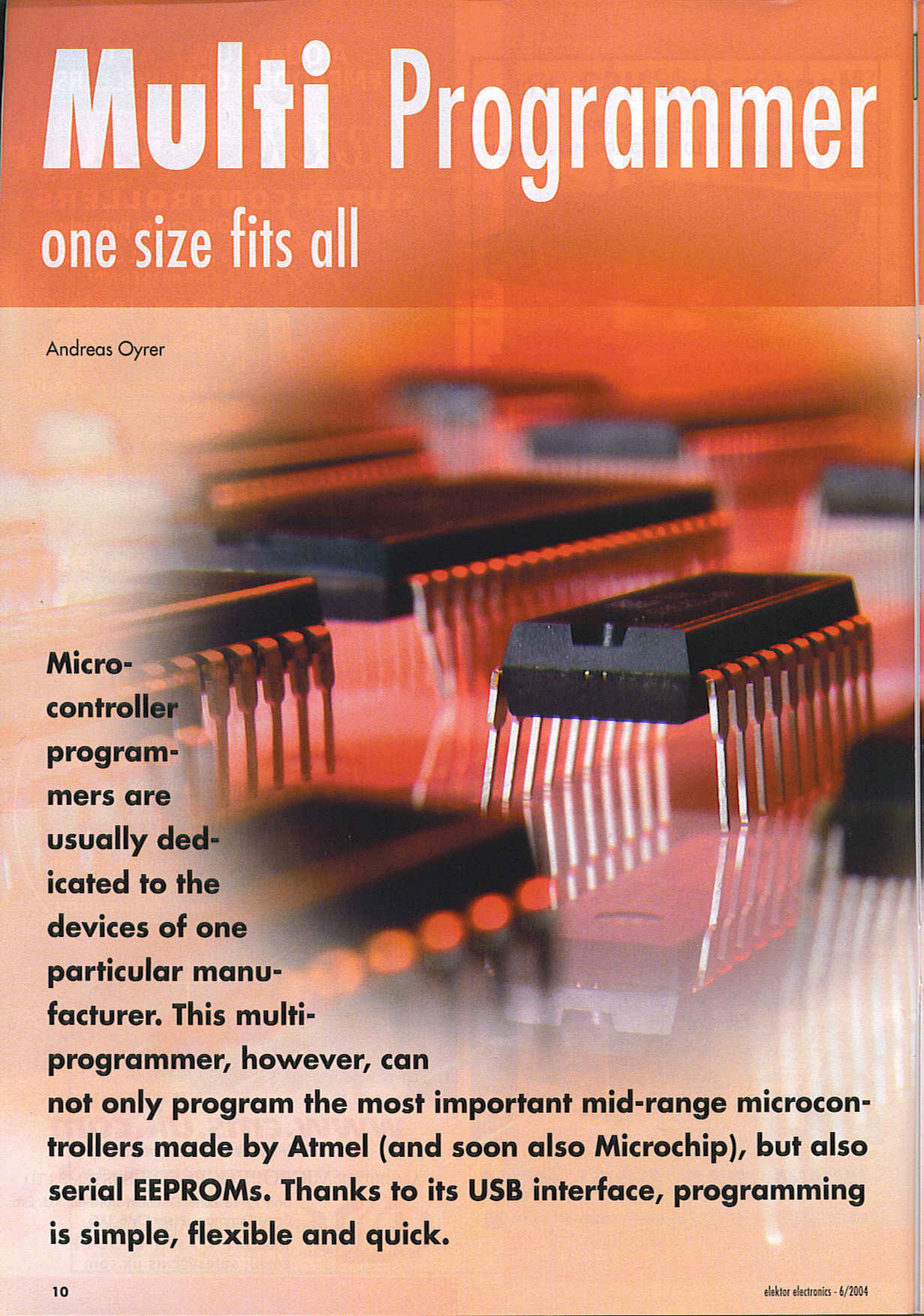

Micro-controller programmers are usually dedicated to the devices of one particular manufacturer. This multi-programmer, however, can not only program the most important mid-range microcontrollers made by Atmel (and soon also Microchip), but also serial EEPROMs. Thanks to its USB interface, programming is simple, flexible and quick.

This multi-programmer is tailored to the requirements of the semi-professional user. It is not designed for the entire range of microcontrollers from one particular manufacturer, but rather for general use with standard 8-bit microcontrollers which have limited memory capacity. The hardware is capable of programming microcontrollers from more than one manufacturer (currently Atmel and Microchip) as well as serial EEPROMs. Since these use different programming algorithms and voltages, this is something of an unusual feature.

'Semi-professional' also means that the programmer is a development tool, and so must be suitable for use while debugging. The programmer must be fast, so that the job of getting software to work correctly does not become a chore.

The programmer must also be controllable, which is achieved by using a USB interface. HID (Human Interface Device) compatibility means that the device will work straightforwardly with versions of Windows from 98SE onwards. All that is needed to operate the multi-programmer is a spare USB port on the PC. The device takes its power from the USB port (it is 'bus-powered'), and so no mains supply is needed.

The microcontroller used does not have its own program memory, and so the firmware is downloaded directly from the PC over the USB cable when it is plugged in. Updating the firmware simply requires changing a file on the PC.

It is also possible to store the firmware in an EEPROM on the programmer board, accessed by the microcontroller on power-up. In this case the USB must be used to upload new firmware versions into the EEPROM.

A special feature of this device is that the microcontroller to be programmed does not have to be removed from the

target circuit and put in the programming socket. The programmer has two ISP (in-system programming) interfaces available, one for Microchip microcontrollers, one for Atmel devices.

USB Microcontroller

At the heart of the hardware is the TUSB3210 (IC1) from Texas Instruments. This is an 8052-compatible microcontroller with a full speed (12 Mbit/s) USB interface, offering four I/O ports each with 8 port pins, a UART, a watchdog timer and an I²C interface. The TUSB3210 does not have its own flash memory, and so the firmware must be reloaded every time power is applied. Software is loaded into the 8k-by-8 (8 kbyte) RAM memory by a built-in boot loader: this can be over the USB interface, or, alternatively, the software can be stored in serial EEPROM IC5 (a 24LC64). The EEPROM is connected to the I²C interface pins SDA and SCL of the TUSB3210: its contents are read whenever the device is reset and copied to the TUSB3210's RAM. If the USB option is used a driver is required on the PC to send the software to the TUSB3210. Whether from the EEPROM or from the PC, once all the firmware has been copied into RAM the boot loader software disconnects from the USB. The program stored in the RAM is run and the device is then reinitialised over the USB.

Programming voltages

IC1 controls all the programming signals and voltages over its 32 I/O pins. In order to generate the programming voltages required by various microcontrollers the 5 V supply from the USB is converted to approximately

13 V using a step-up regulator. Normally the output voltage of the switching regulator would be a constant 12 V, but a diode in the feedback path of IC3 raises the output voltage by the forward voltage drop of the diode: this higher voltage allows PIC microcontrollers to be programmed.

The programming voltages are switched as required using p-channel and n-channel FETs. A voltage of 0 V, 5 V or 12 V can be made to appear on pin 1 or pin 31 of the programming socket. A voltage of 13 V is available for the MCLR signal on ISP connector K3, which is used for programming PICs. Diodes D5 and D7 reduce this voltage back down to 12 V: this lower voltage is used when programming Atmel microcontrollers.

TTL gates with open-collector outputs (type 74LS07) are used to drive the FETs. This allows a voltage of 0 V to appear between gate and source, ensuring that the transistors can be fully turned off. If used directly, the voltage on the I/O port pins could only rise to about 3.3 V, giving a gate-source voltage of 10 V: the transistors would then still conduct.

Some microcontrollers require a programming voltage on the reset or crystal inputs. In the case of the 90S1200, for example, a minimum voltage of $0.85 \cdot V_{CC} = 4.25$ V (assuming a 5 V supply) is required on the reset input. Since the TUSB3210 runs from a 3.3 V supply it can only deliver a logic high level of 3.3 V; the remaining gates in IC4 are used to produce a high level of over 4 V.

Programming socket

Most devices can be programmed directly in socket IC5. Crystal X2 provides a clock source for Atmel 89Cxx and 89Sxx type microcontrollers. Because of the limited number of I/O pins offered by the TUSB3210 only a

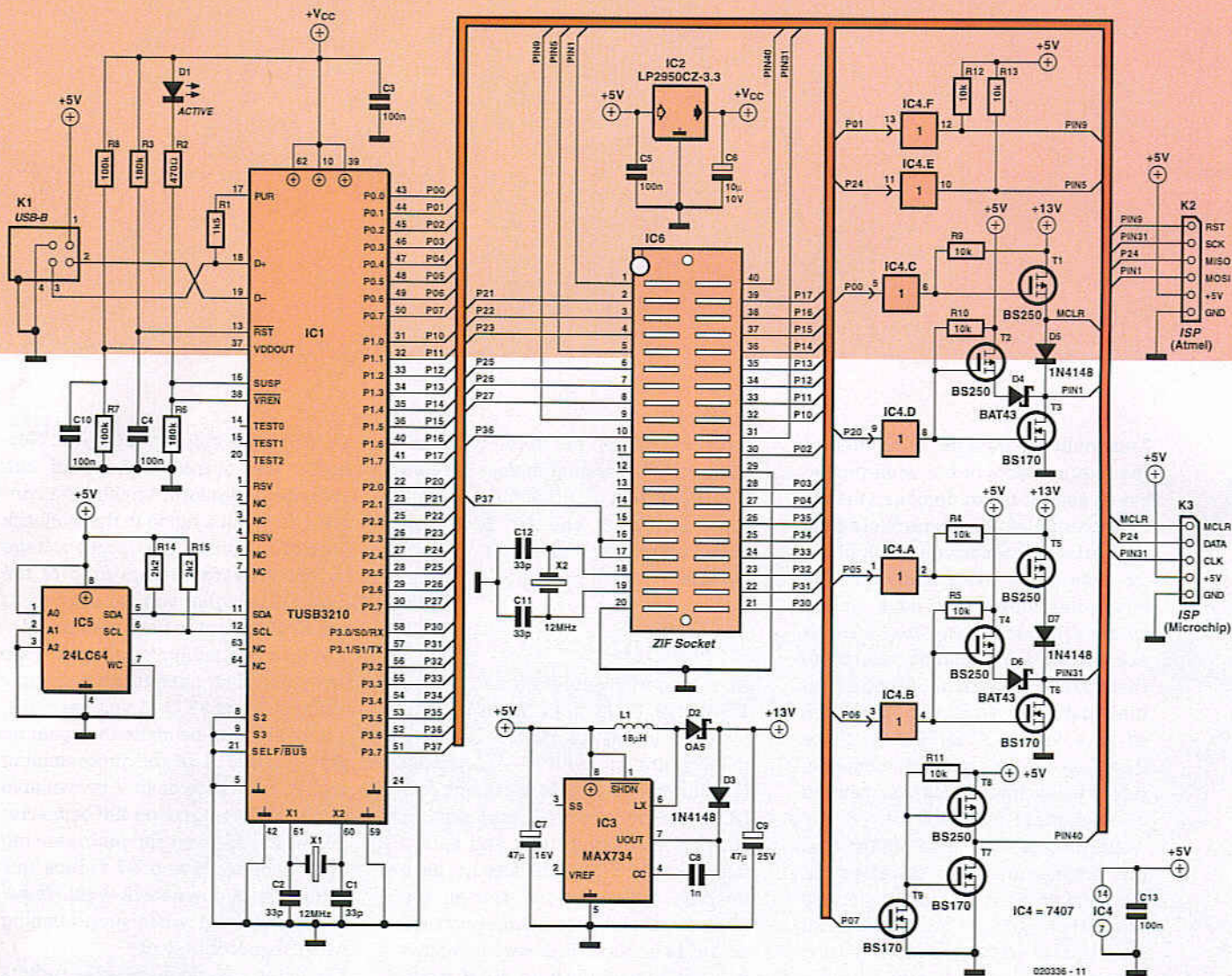

Figure 1. The TUSB3210 includes I²C and USB interfaces, and so the only additional hardware needed is a step-up converter and a few MOSFETs.

certain range of microcontrollers can be programmed. Other (larger) microcontrollers can, however, be programmed using the ISP connectors. On closer inspection, you will notice that there is no ground connection on pin 10, as would be required, for example, by an 89Cx051. Since the supply current is not particularly high during programming, it is sufficient to provide the ground via port pin P3.6 of IC1. The voltage does indeed rise a little above ground, but remains within reasonable limits.

PC software

The software running on the PC is written in Delphi 7. The menu language can be set (under Setup, as shown in Figure 2) to English, French or German. This setting, along with all other settings, is stored in the registry

and automatically recalled when the program is next run.

Also under Setup are options to control whether signature bytes are read, and whether the device memory contents are verified after programming. The device type is set under the Device menu item (see Figure 3). There are two sub-menus available here: Socket (i.e., IC5) and ISP Connector (i.e., using connectors K2 and K3). Currently only the Socket option is available. The next choice is between Atmel MCU and serial EEPROM. Under Atmel MCU the available ranges of microcontrollers are 89Cx051, 89C5x, 89Sx and the two AVR microcontrollers, 90S1200 and 90S2313. Of course, functions such as lock bit and fuse bit programming are supported.

On 89C5x microcontrollers only lock bits 1 and 2 can be programmed, since there are not enough port pins avail-

able on the TUSB3210 to allow programming of lock bit 3. None of the lock bits can be programmed on 89Sx-type microcontrollers. If a type 90S1200/90S2313 microcontroller is selected, then when configuring the second fuse bit two variants (the RCEN fuse bit and the FSTRT fuse bit) are displayed. If the microcontroller type is detected, the text changes to show the name of the fuse bit supported by the device in question. If a serial EEPROM device is selected, there is in some cases more than one device type ending in the same digits (the digits correspond to the size of the memory). Devices in the 24AAxx and 24CxxC series with the same capacity differ, however, in their page size: this is the number of bytes that form one 'row' in the memory that can be programmed in one cycle (approximately 2 ms). The bigger the page size, the quicker the

overall programming operation. All programming functions such as program, verify, erase, read, program EEPROM, read EEPROM, read fuse or lock bits and detect device are directly available either using buttons or under the Action menu (see Figure 4). If the microcontroller has been selected as autodetect, then it can be tested using Detect Device. This causes the signature bytes to be read from the device. The bytes are analysed and information including the memory capacity, programming voltage and exact part number are displayed in the upper right-hand corner of the window under Device.

When an action is selected, the signature bytes are first automatically read out of the microcontroller before the action is carried out. The signature byte test can be disabled by deactivating the Read signature bytes option in the Setup menu. This might be necessary if a fault in the microcontroller makes it impossible to read out the signature bytes.

The Read action reads the entire memory contents out of the device. The number of bytes to be read is determined from the information in the signature bytes or by the digits at the end of the part number in the case of a serial EEPROM. If, in the case of a microcontroller, the signature byte has not been read, then the maximum possible memory size for a device in the selected series is used. For example, if the 89Cx051 series is selected, then 4 kbyte will be used, since this is the memory capacity of the biggest device in this series, the 89C4051.

Under the Buffer menu you can choose whether the data in the buffer can be altered using the hex editor (Buffer editable). You can also select whether data in the buffer is synchronised with the data in the previously-opened file before any write or verify action is started (Update buffer from file).

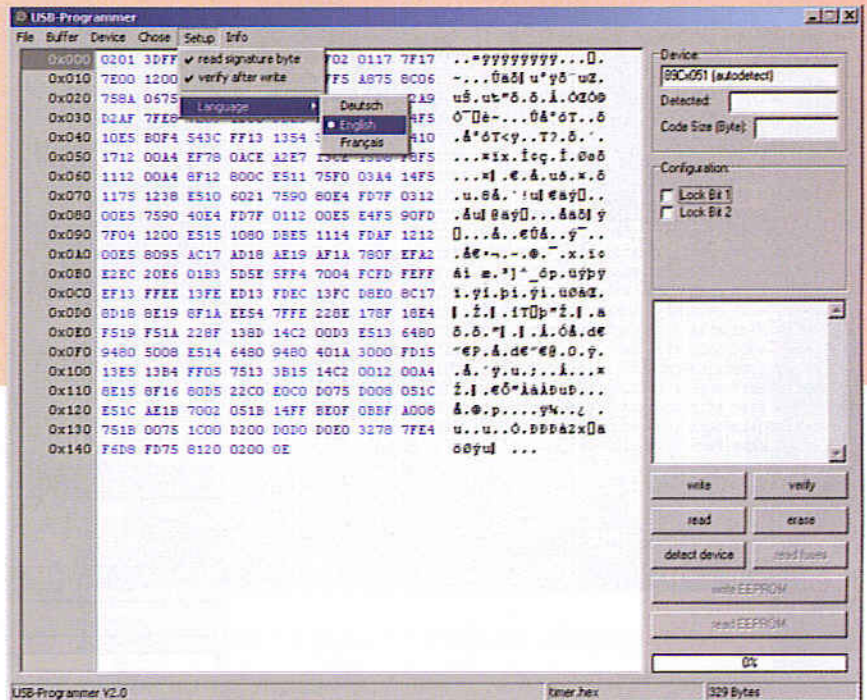

Figure 2. The setup menu

Protocol

A protocol is of course required to ensure that data communications between the PC and the programmer are kept in step. The first byte from the PC to the programmer contains information on the selected microcontroller or memory: the value 1 specifies the

89Cx051 series, the value 2 the 89C5x and 89Sx series. The second byte gives the selected action: 1 to read the signature bytes, 2 to erase and so on. Succeeding bytes contain further information, for example the programming voltage for an 89C5x microcontroller or the page size for a serial EEPROM. When programming, an extra byte is

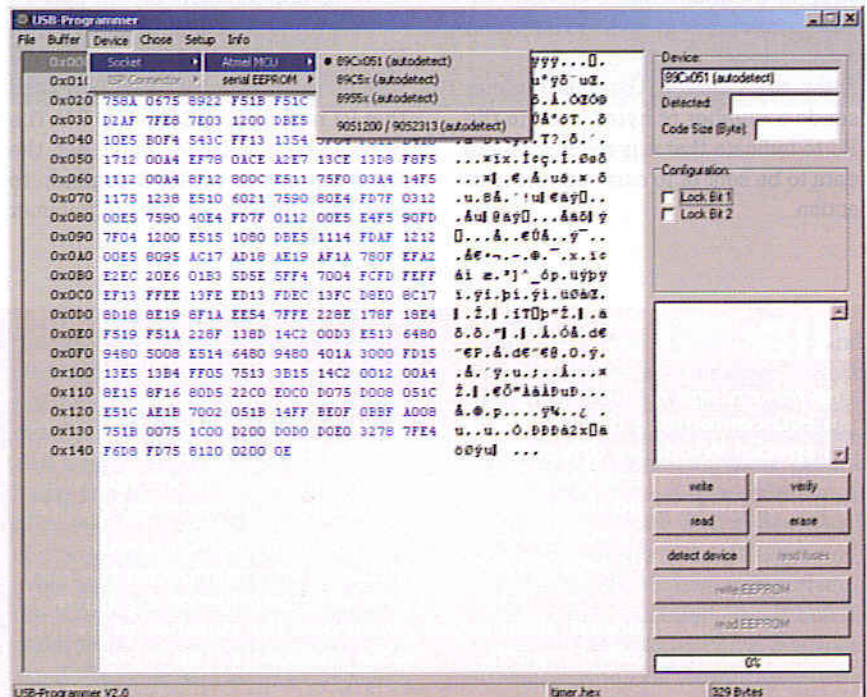

Figure 3. Device selection

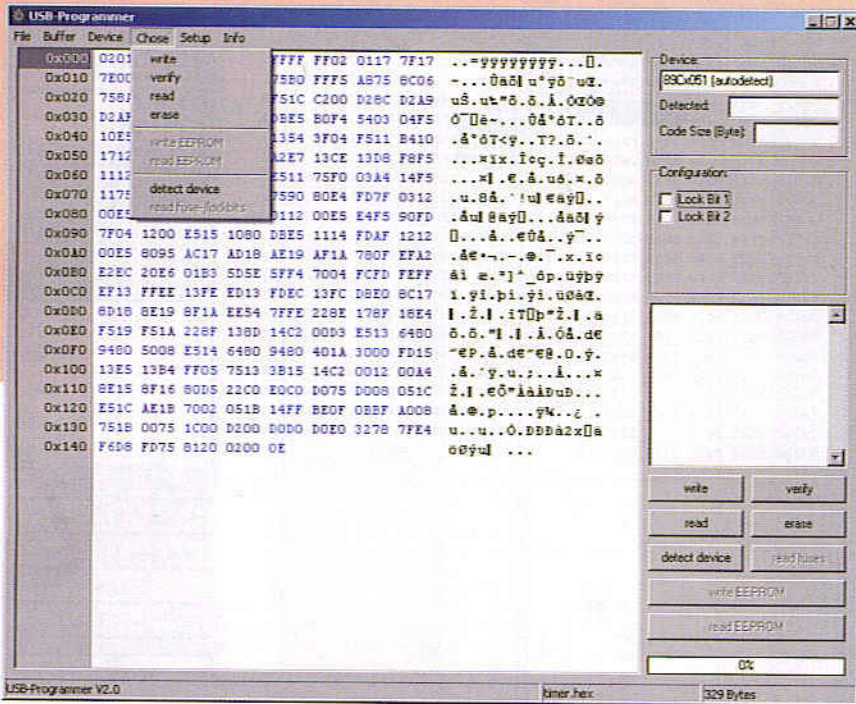

Figure 4. Using 'Detect Device' the signature bytes and other data can be displayed in the upper right-hand corner of the window.

used which gives the number of bytes in each packet. A further byte indicates whether the data packet sent is the last one (byte is zero) or whether further packets follow (byte is 1). When reading, a count of the number of bytes to be read is sent to the programmer. Generally the size is specified in kilobytes or kilobits. The software in the programmer can deduce how to interpret the value from the first bytes that were sent. After each action the programmer sends a number of bytes back to the PC to indicate that it is ready for more data to be sent or to carry out the next action.

Programmer software

The software in the programmer was written using the Keil μ Vision2 C compiler. The main routine first disables the watchdog timer and then takes all pins on the programming socket to 0 V using the function *ResetProgrammer()*. Next the USB registers are set up.

When the boot loader software in IC1 completes, it disconnects from the USB by taking output pin PUR low so that R1 no longer pulls up to 3.3 V. The downloaded software must set the SDW bit in the MCNFG register to reactivate this output: the programmer

will then reappear on the bus.

The PC host then sends a number of SETUP tokens to identify the device and configure its USB interface. These tokens are processed by endpoint 0. The data transferred includes the unique address for the device, which is subsequently used to communicate with the programmer. Various descriptors are also transmitted to the host during the setup phase, providing information about the device and its functions and characteristics. These include the report descriptor, which in this case identifies the programmer as an HID-compatible device.

Once all the descriptors have been sent to the PC, initialisation of the USB interface on the device is complete and it is ready to operate. The direction of data transfer is specified by a token. If the TUSB3210 detects an IN token, then data, such as status information or a data packet, is to be sent from the programmer to the host. If an OUT token is received, then the data packet is unpacked by the programmer and the payload programmed into the device (assuming that that is the selected action).

HID

The advantage of initialising as an HID-compatible device is that no special Windows driver is required to communicate data between the PC and the programmer. Windows versions from 98SE onwards support this standard.

Under the HID standard, data is exchanged in so-called reports. During USB enumeration the PC provides a number of descrip-

tors. The device descriptor includes information such as the Vendor ID (VID), Product ID (PID), and the USB version supported by the connected device.

The configuration descriptor includes information on the current consumption of the hardware and the number of available endpoints. The report descriptor gives the size and number of reports to be

exchanged between the PC and the programmer. It specifies how many bytes are to be sent or received and the function of the attached device (mouse, keyboard, joystick, memory stick etc.). More detailed information on USB and HID can be found on the USB homepage at www.usb.org/home.

Programming routines

The data received is decoded by the routine `DecodeProgrammerData()` in the file `Prog.c`. The first byte of the 64-byte report contains the code for the selected microcontroller, while the second gives the desired action. These values are used to call one of a number of different programming algorithms for different devices, as given in the microcontroller data sheets.

Each device series has its own power-up routine which applies power to the correct pins and sets the programming signals used to defined levels. Once an action has been successfully completed, the routine to reset the programmer is called, which sets all the signals on the programming socket back to 0 V. Since in general it is desired to program more than the 64 bytes contained in one report, the PC must send a further data packet to the programmer as soon as the previous one has been processed. The programmer sends a defined message to the software running on the PC to notify it that the next packet can be sent.

The PC then prepares the next report packet and sends it to the hardware. The last packet to the USB programmer contains a zero byte. When the device is read, data is also transferred in reports of 64 bytes each, where the first byte gives the number of valid bytes in the packet.

The above description of the programmer software can give only a broad overview of its operation. More detail can be found in the thoroughly-commented and clearly-structured software itself.

Construction and operation

Populating the printed circuit board would be child's play were it not for

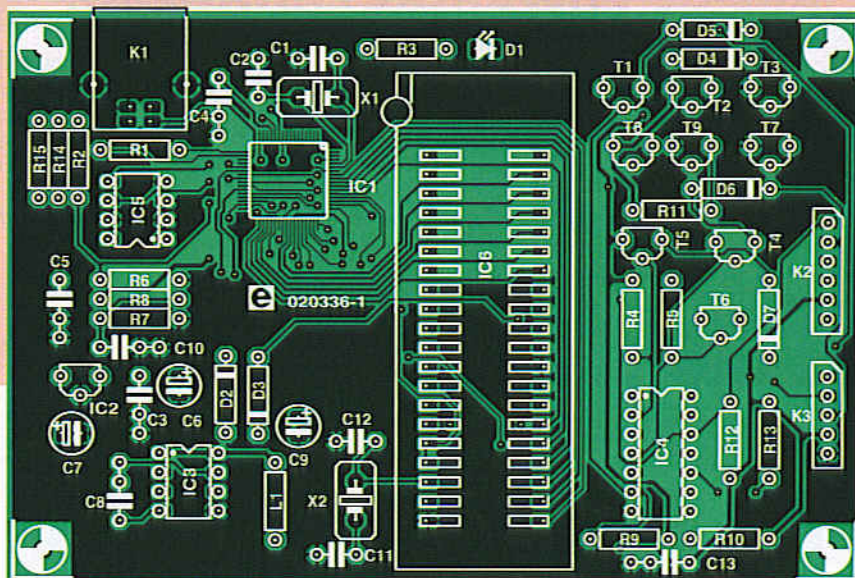

Figure 5. Component mounting plan for the double-sided printed circuit board.

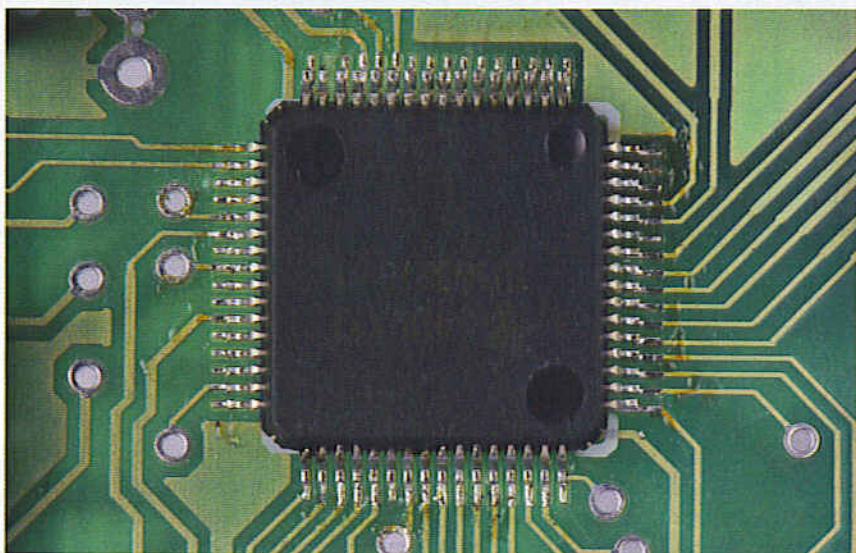

Figure 6. Tiny and tricky to solder: the USB microcontroller comes in a 64-lead SFPF package.

the tiny TUSB3210 in an S-PFP-G64 package with many fine leads. Soldering such SMD ICs requires not just a steady hand but also nerves of steel and a good deal of confidence. After fixing the IC in place with a drop of glue, you must take the soldering iron and do what you would normally try to avoid at all costs: rather than soldering the IC's leads to their corresponding pads, solder all the leads together. This should be done as quickly as possible, so the device does not get too hot. When this big short-circuit and the IC have cooled down, lay some unused

desoldering wick across the pins and use it (and not a solder pump!) to suck away the excess solder. Again, take care not to get the IC too hot. Finally, check with a magnifying glass under a good light, and using a multimeter, that all the pins are well soldered and no longer shorted to their neighbours. Once the TUSB3210 has been correctly soldered to the printed circuit board, the remaining construction is relatively straightforward. All the ICs (except for the tiny voltage regulator) are provided with sockets. Even the zero insertion force socket should be fitted in a

Devices currently supported

The programmer firmware can easily be updated to the latest version at any time: you simply need to write the new firmware into the EEPROM and, if necessary, replace the software on the PC.

Currently the firmware is capable of programming the microcontrollers and EEPROMs listed below. An update is expected shortly that will support PIC microcontrollers and ATmega devices.

This, as well as all future updates, will be included with the PC software available for free download from the Elektor Electronics website under product number 020336-11, see month of publication.

Atmel microcontrollers:

89C1051, 89C2051, 89C4051,

90S1200, 90S2313, 89C51, 89C52, 89C55, 89LV51, 89LV52, 89LV55, 89S53, 89S8252

EEPROMs:

24xx00, 24xx01, 24xx02, 24xx04, 24xx08, 24xx16, 24xx32, 24xx64, 24xx128, 24xx256, 24xx512

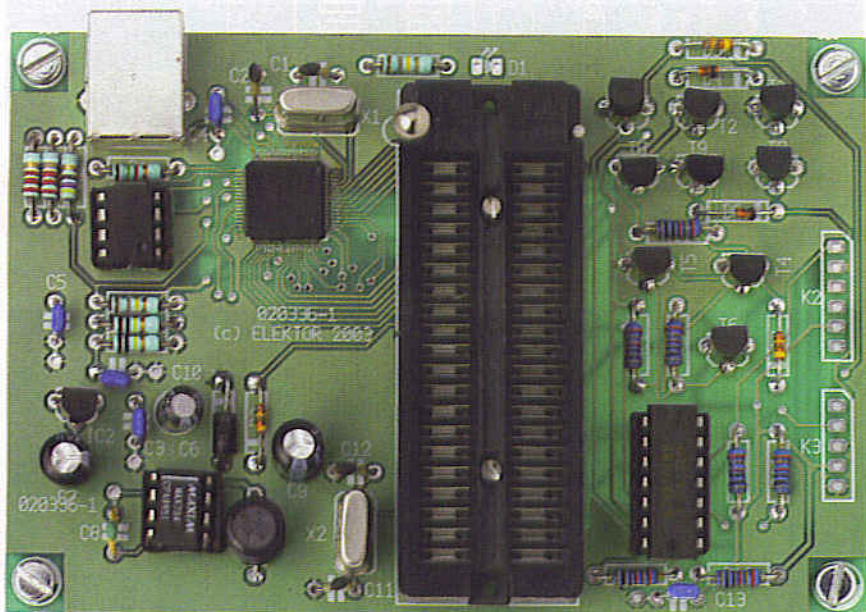

socket rather than being directly soldered to the board.

When construction is complete and you have inspected the board, you can carry out the first test. If a ready-programmed EEPROM is available, no Windows driver will be required. If the programmer is now connected to the USB, it should appear in the Device Manager as an HID-compatible device. You are now ready to program your first microcontroller.

If no serial EEPROM is fitted, the firmware must be downloaded over the USB. The TUSB3210 boot loader registers itself, Windows recognises the new device and will now need the Texas Instruments device driver. This driver (called the *TI Aploader Driver*) is not provided as part of the *Elektor Electronics* disk or download, but can be obtained for free from the TI website at www.ti.com. Select the directory with the file TUSB3210.inf and install the driver and then the file Aploader.sys from the same directory.

Finally you will be asked for the directory containing the firmware: enter the path to the file TUSB3210.bin. This will automatically be copied into the directory /System32/drivers, along with the file Aploader.sys. If the programmer is now reconnected, the driver will send the firmware from the file /System32/drivers/TUSB3210.bin; after a brief delay the code will start executing on the programmer. The programmer will now be re-enumerated as an HID device.

(020336-1)

COMPONENTS LIST

Resistors:

R1 = 1k Ω
R2 = 470 Ω
R3, R6 = 180k Ω
R4, R5, R9-R13 = 10k Ω
R7, R8 = 100k Ω
R14, R15 = 2k Ω

Capacitors:

C1, C2, C12, C13 = 33pF
C3, C4, C5, C10, C11 = 100nF
C6 = 10 μ F 16V radial
C7, C9 = 47 μ F 16V radial
C8 = 1nF

Semiconductors:

D1 = LED, red
D2 = OA5 or 1N5817 (Farnell # 573-097)
D3, D5, D7 = 1N4148
D4, D6 = BAT43
IC1 = TUSB3210PM
IC2 = LP2950CZ-3.3 or LE33CZ (Farnell # 302-4568)
IC3 = MAX734CP
IC4 = 74LS04
IC5 = 24LC64
IC6 = 40-way ZIF socket with wide slots
T1, T2, T4, T5, T8 = BS250
T3, T6, T7, T9 = BS170

Miscellaneous:

K1 = USB 'B' connector, angled, PCB mount
K2 = 6-way pinheader
K3 = 5-way pinheader
L1 = 18 μ H miniature choke
X1, X2 = 12MHz quartz crystal
PCB, available from **The PCBShop**
Disk, PC software and firmware / source code files, order code **020336-11** or Free Download

Forest Electronics – PIC and AVR ANSI C Compiler Products

FED's ANSI C Compiler for PIC or AVR processors

- Fully integrated editor with syntax highlighting, multiple pages etc.
- Full project support - include and manage multiple source files, simulator, assembler files and notes/comments within one project
- Fully integrated simulator and waveform analyser step from C line to C line, or examine code in assembler form. View device pins using a logic analyser application.
- Simulator supports LCD modules, keypad, buttons, LED's, displays, analogue inputs, serial and asynchronous data.
- Designed to ANSI C standards
- PIC - Supports 18xxx, 16xxx, 12xxx series 14 and 16 bit core processors
- AVR - Supports standard and MEGA core processors
- Generates MPLAB/AVR Studio projects and source files and completely standard hex output files.

Prices from £45.00 – www.fored.co.uk for full details.

WIZ-C / AVIDICY

Drag and Drop rapid application development using ANSI C for PIC and AVR

- Rapid Application Development for the PIC or AVR microcontroller using the C language (WIZ-C for the PIC, AVIDICY for the AVR)
- Drag and drop your software component selections on to your design
- Included components support timers, serial interfaces, I2C, LCD, 7 Seg displays, keypads, switches, port controls, many bus interfaces including IIC and Dallas iButton, AVR/PIC Hardware, and more.
- Connect software components to MCU pins by point & click
- Parameters set from drop down list boxes, check boxes, or text entry
- Links your code automatically into library events (e.g. Button Pressed, Byte Received etc.)

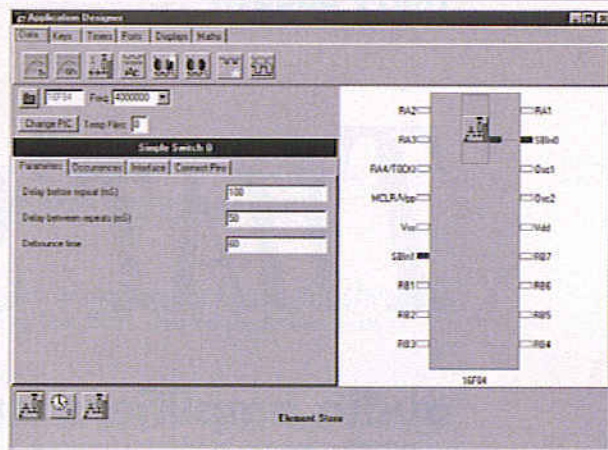

- Automatically generates your base application including full initialisation, interrupt handling and main program loop
- The complete C Compiler and AVR Simulator programs are integrated into AVIDICY - total editing / compilation / assembly / simulation support in one program
- Also includes the Element Editor to enable you to create your own components with ease.
- Demonstration available from our web site

Prices from £50.00 - full details from www.fored.co.uk



Forest Electronic Developments

12 Buldowne Walk, Sway
LYMINGTON, Hampshire, SO41 6DU.
01590-681511 (Voice/Fax)

Email –
"info@fored.co.uk"



Full details from - www.fored.co.uk

Electronic prototyping products and services from the makers of Veroboard



- Veroboard
- Prototyping Boards
- Extender Boards
- Wiring and Terminal Pins
- Standard Backplanes
- Verowire
- Cardframes
- Front Panels
- IBM PC Brackets

vero

TECHNOLOGIES

Vero Technologies Limited

Unit 25, Solent Trading Estate, Shamblehurst Lane, Hedge End, Hants, SO30 2FY

• 01489 776931 telephone • 01489 776938 fax • sales@verotl.com email •

sales: 087 0225 9505 internet: www.verotl.com

Harry Baggen

THAT'S CLASS...

audio amplifiers from A to T

The final amplifier is the power source of every audio installation. Its job is to convert a small alternating voltage into a powerful signal suitable for driving loudspeakers, with as little distortion as possible. During the years since the invention of electronic audio systems, designers have come up with various approaches to this problem. It all started with Class A...

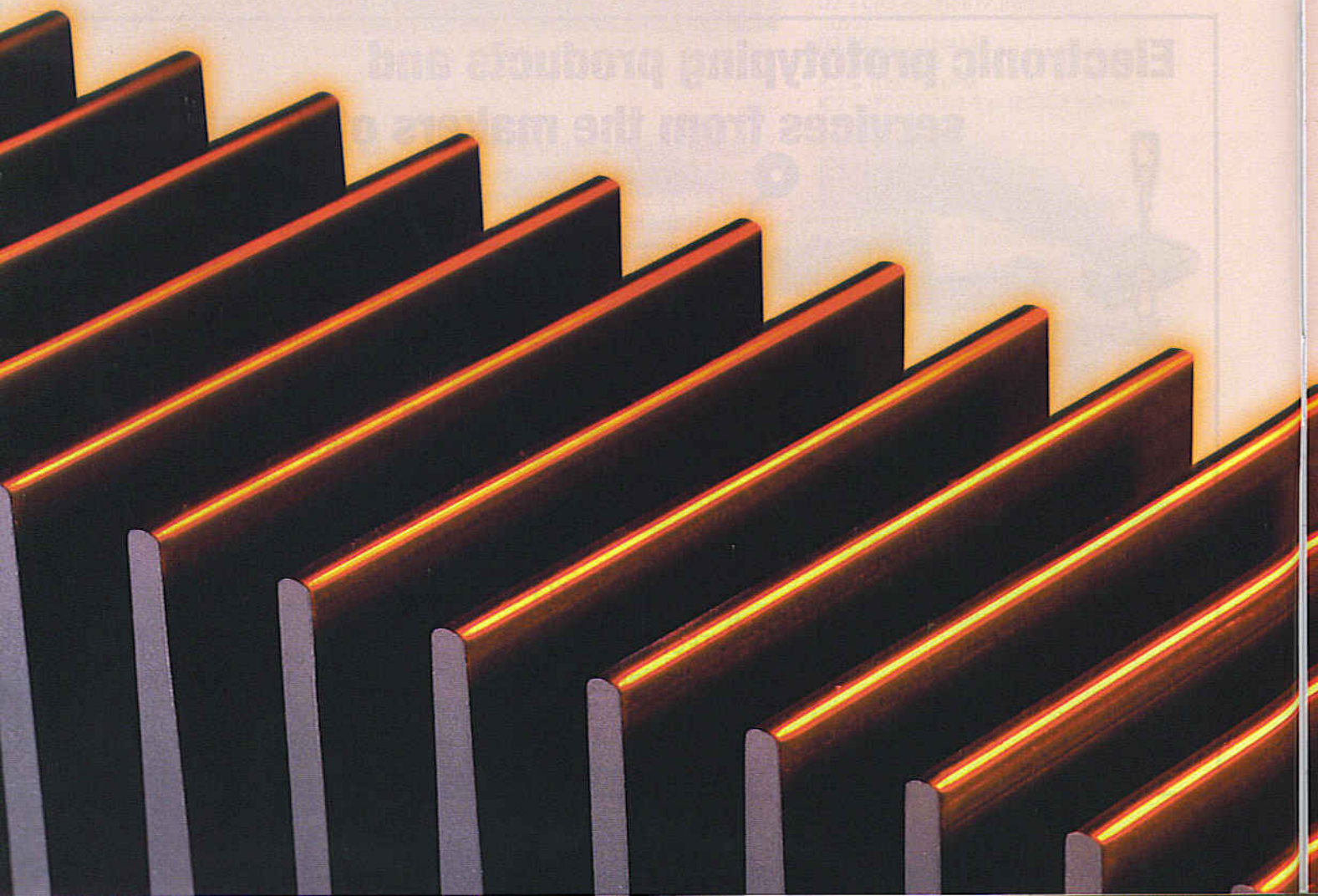

A little more noise, a lot more power

For many people, the amount of power an amplifier can produce is an important factor in judging its characteristics (So your amplifier delivers 2×40 watts? Mine does 2×70 !). But in practice, power plays only a minor role.

You can already make a lot of noise with just a few watts. If you use a set of loudspeakers that can produce a sound pressure level of 86 dB at 1 W (which is a value commonly stated by manufacturers in speaker specifications), you can manage 90 dB with just 2.5 watts. With 25 watts, you have enough for 100 dB. That's already rather loud (and harmful to your ears as well!).

Our ears perceive each 6-dB increase in the sound pressure level as a doubling of the volume level, but this requires increasing the power by a factor of four. This means that if you really want to have a bigger final amplifier with more power than what you presently have, you will need an amplifier with at least four times as much power to actually notice any difference.

Delivering a large amount of power is not a simple task for an amplifier. Voltage amplification and current amplification are both necessary in order to provide sufficient power to the speakers connected to the amplifier. This is because loudspeakers have an efficiency of only a few percent, which means that several watts are certainly necessary to generate an adequate sound pressure level in a living room. In the case of concerts or outdoor events, quite a bit more is required, and the necessary power can easily amount to several kilowatts. To produce power amplification in a final amplifier, various concepts have been developed for using transistors or FETs to generate high-quality output signals and/or improve the efficiency of the output stage. (Here we leave valve amplifiers out of the picture.)

When devising an output stage, the designer must take into account the

specific properties of the semiconductor devices being used. If we could work with 'ideal' transistors or FETs, it would be much easier to build good amplifiers. Unfortunately, all semiconductor devices suffer from non-linearity in their amplification characteristics, and this causes major problems, especially for processing analogue signals. These problems can be minimised by using properly dimensioned feedback. There are also other nasty side effects that also occur, depending on the selected configuration, such as the notorious problem of crossover distortion.

Especially with large amplifiers, heat generation is another factor that must be taken into account. It can lead to far-reaching thermal effects, such as drift of the quiescent current setting and thermal modulation distortion. Final amplifiers are normally classified according to the configuration of the output stage. This largely determines their efficiency and quality, since the output stage is where the actual power amplification takes place.

The various amplifier configurations are designated using the letters of the alphabet, although the letters do not say anything about how they work. It all just started with the first letter of the alphabet.

Figure 1. A Class A amplifier has very low efficiency, but it is totally free of crossover distortion.

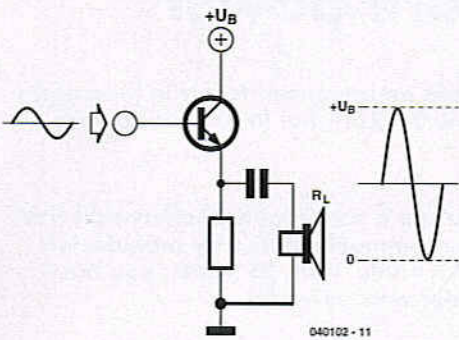

Figure 2. In a Class B configuration, each transistor conducts for half of the sine-wave cycle. Here problems arise around the zero-crossing point.

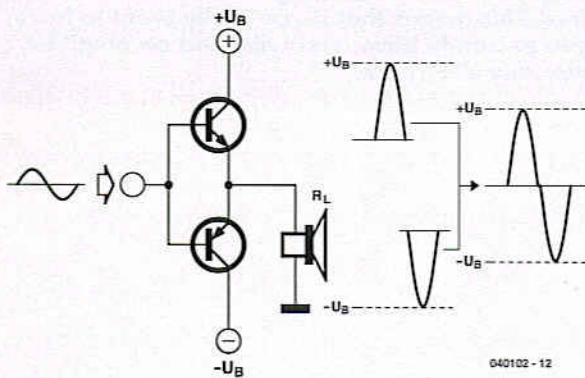

Figure 3. Class G uses a tracking power supply whose voltage is continuously adjusted to match the signal amplitude.

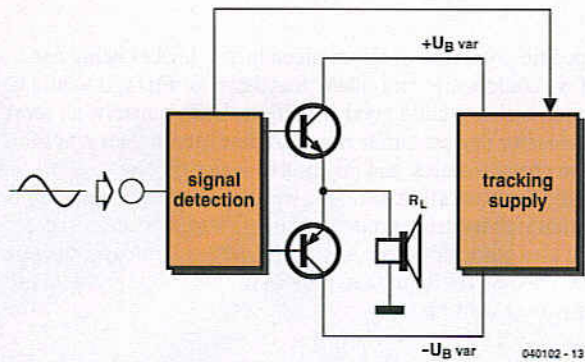
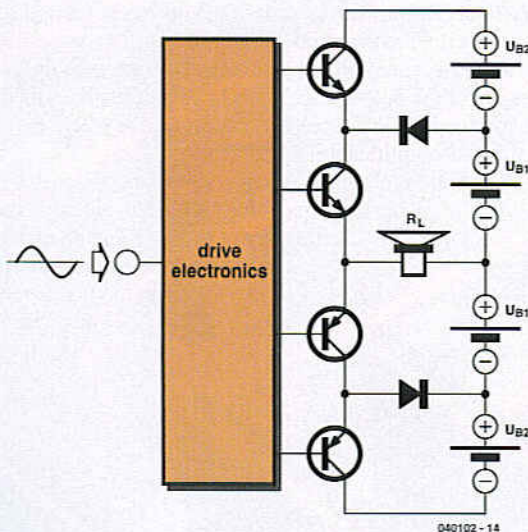

Figure 4. Class H limits itself to switching between several different supply voltages (in this case two).



Class A

Here we begin with the simplest configuration, the Class A final amplifier, which is also one of the best configurations for high-quality audio reproduction. In its basic form, this configuration can be implemented using a standard emitter follower (Figure 1). The quiescent current through the transistor is equal to the peak AC output current, which means that the transistor is biased in the middle of its working range and simply conducts more or less current when driven by an alternating voltage. The efficiency is very low: 25 % at maximum output amplitude, and even less at low signal levels. The efficiency can be improved by using a symmetrical design with two transistors, but even then the highest efficiency that can be achieved is 50 %.

Class B

The Class B configuration employs two transistors, each of which conducts for exactly half of the signal cycle (Figure 2). In the quiescent state, no current at all flows through the transistors. The efficiency of a Class B output stage is around 78 %, but the primary disadvantage of this configuration is the 'transfer distortion' that occurs each time the load must be transferred from one transistor to the other. Due to the sharp bend at the bottom end of the transfer characteristic, the two halves of the signal waveform do not properly align with each other. This leads to the notorious problem of crossover distortion, which is a quite audible degradation of the signal waveform.

To solve this problem, Class A and Class B were combined to produce Class AB. This is a Class B configuration in which a small quiescent current flows, causing the output stage to actually work in Class A at low power levels. This approach is presently used in various forms in most final amplifiers. The efficiency remains approximately the same as for Class B.

G and H

Hey, just a minute! Haven't we skipped a few classes? We have indeed, but we did so on purpose. Classes C, E and F also exist, but they are actually only suitable for high-frequency applications, which means they more or less fall outside the scope of what we're talking about here. And the design of Class D amplifiers is so different from Class A and Class B that we decided to deal with it separately. So, let's first look at classes G and H, which have an important feature in common. This is that in both of these classes, the supply voltage is adjusted according to the magnitude of the output signal. In Class G (Figure 3), the supply voltage is continuously adjusted to match the desired amplitude of the output signal. Such a 'tracking' supply voltage can be implemented relatively easily using modern switching power supplies, although it is of course important to have a good regulator circuit to allow the supply voltage to respond sufficiently quickly to changes in the amplitude of the signal generated by the output stage.

In Class H (Figure 4), what happens is essentially the same as in Class G, except that here the supply voltage is switched between several distinct levels (usually two) instead of being

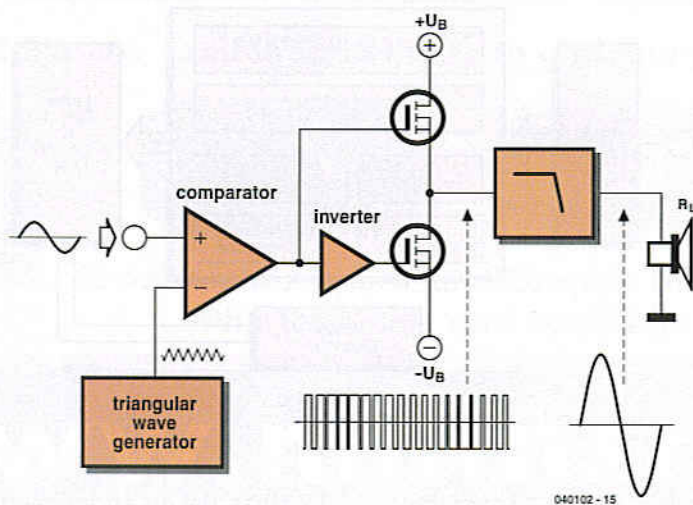

Figure 5. A Class D amplifier consists of a pulse-width modulator with a power output stage and a low-pass filter.

continuously varied. This allows the dissipation in the output stage to be considerably reduced, especially when large amounts of power are involved.

Class D

With the Class D amplifier configuration, the letter 'D' doesn't have anything to do with 'digital' (that's just a coincidence). It refers to a switching amplifier that uses pulse-width modulation (Figure 5). The input signal is compared with a triangular waveform, and the signal from the comparator switches the output stage to the positive or negative supply voltage. This is done using a very high switching frequency, which is usually ten times or more higher than the audio bandwidth (which means 200 kHz or above).

With this form of modulation, the pulse width depends on the level of the input signal. If a low-pass filter is placed after the output stage, the pulse-width signal is integrated and what is left is an analogue signal with the same form as the input signal, but of course amplified.

As the output stage only has to switch, its efficiency is very high. However, there are also a number of drawbacks to this approach. It is rather difficult to keep the signal waveform

free of distortion, a hefty output filter is required, and drastic measures must be taken to limit radiated interference. For low-distortion amplification, it is always necessary to use negative feedback (analogue or digital).

Classes S and T

Although the working principle of the Class D amplifier is already several decades old, it never managed to become truly established in hi-fi applications. This was primarily due to excessive distortion and a lack of good semiconductor devices (fast power FETs). In the meantime, several manufacturers have devised variations on this theme, and in many cases they have given them their own designations. For instance, Crown came up with the Class I amplifier, Sony developed its S-Master technology, and Tripath has devised its Class T amplifier. Unfortunately, the nice alphabetic sequence has been abandoned in favour of manufacturer-specific abbreviations. In its S-Master technology, Sony combined several techniques to make the Class D configuration suitable for domestic hi-fi applications. Here the process of converting the incoming signal into a corresponding pulse-width signal is called 'complementary pulse length modulation' (C-PLM). Extensive atten-

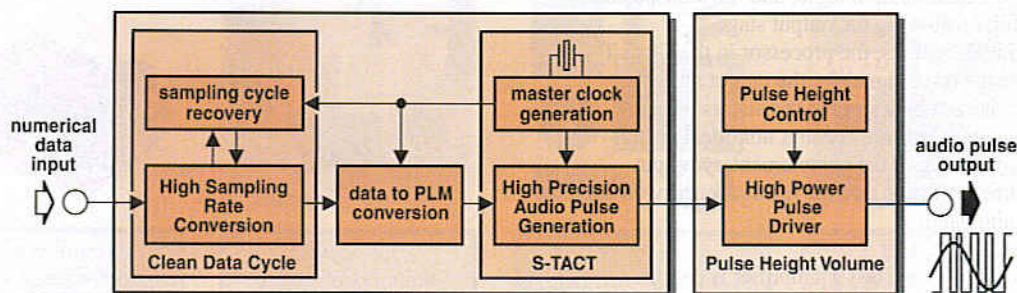
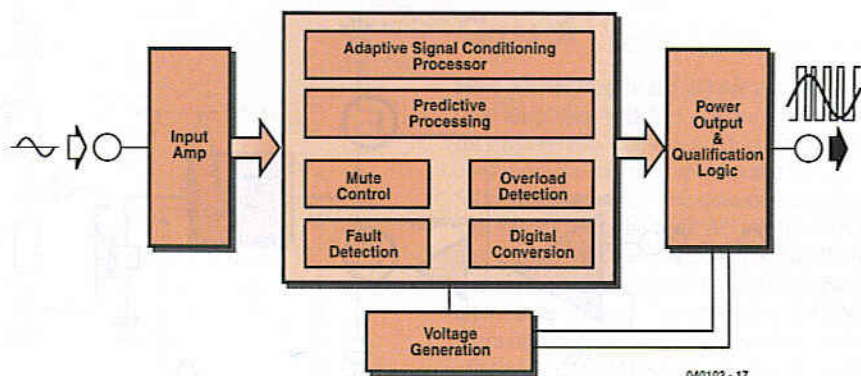

Figure 6. Block diagram of a Sony S-Master amplifier.

Figure 7. The Tripath Class T amplifier is an 'intelligent' elaboration of the Class D principle. Here a processor continuously monitors the input signal and adjusts the switching signals.



tion was given to suppressing jitter. This was accomplished by using an extremely accurate clock signal and a circuit called 'clean data cycle' that corrects the positioning of the output pulses if necessary (see Figure 6).

The method used to implement volume control is certainly an unusual feature of the Sony approach. In a normal Class D design, the full pulse waveform is always present at the output, with an amplitude of 50 to 100 volts peak-to-peak. Particularly with small output signals, it is very difficult to fully eliminate all residual components of the pulse waveform from the filtered signal. In the Sony design, the volume is regulated by adjusting the supply voltage for the output stage. This prevents any information from being lost at low signal levels. This technique has an effective range of 50 dB.

Another company, Tripath, has developed a technique that according to them combines the signal quality of Class A and AB amplifiers with high efficiency (around 80–90%). This is done using a combination of analogue and digital circuitry, together with digital algorithms that modulate the input signal using a high-frequency switching waveform. The algorithms developed by Tripath are derived from adaptive and predictive algorithms already used in telecommunication systems. With the Tripath amplifier, the majority of the analogue and digital circuitry is housed in a single IC, which may also include the output transistors (depending on the power). The block diagram of the amplifier is shown in Figure 7. The input signal is first buffered by an input stage. From there it passes to the Digital Power Processing block, which contains the signal processor, a digital conversion function, mute switching, overload protection and error detection. The output stage is driven via the qualification logic, and the loudspeaker is connected to a filter following the output stage. Thanks to its special algorithms, the processor in the Class T amplifier can shape the drive signal for the output stage to match the specific characteristics of the transistors used in that stage. This shaping takes into account non-ideal switching behaviour, mismatching of the complementary output transistors, dead-time distortion and the residual energy of the oscillator in the audio band.

The switching frequency of a Class T amplifier is continuously adapted to the magnitude of the input signal. At low input levels, the switching frequency is quite high (around

1.2 MHz). This has a beneficial effect on signal quality. The switching frequency gradually drops as the input level increases, in order to increase efficiency. The switching frequency ultimately reaches its lowest value (around 200 kHz) when the output is driven to maximum amplitude. Besides this, a form of noise shaping is applied to the peaks of the output signal in order to improve the signal waveform. As a result of all these measures, the Class T amplifier can deliver a sound impression that reminds listeners of audiophile analogue amplifiers.

The future

With the steady advance of digital audio, some form of digital output stage will ultimately be found in many consumer amplifiers. The reasons for this are higher efficiency, smaller size and lower manufacturing cost. It's difficult to estimate whether this development will also come to prevail in the high-end realm. There are presently only a few high-quality digital amplifiers on the market. But if you'd like to try it for yourself, you can start by building the Clarity amplifier described in this issue.

(040102-1)

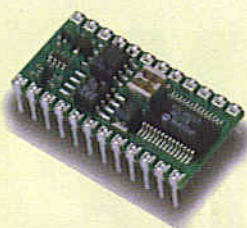

BS2-IC

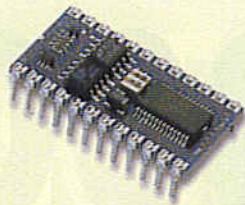

BS2-SX

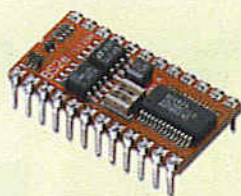

BS2E-IC

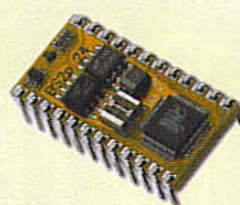

BS2P/24



BS2P/40

Parallax BASIC Stamps - still the easy way to get your project up and running!

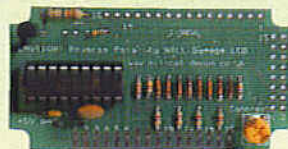

Serial Alphanumeric and Graphic Displays, Mini-Terminals and Bezel kits

www.milinst.com



Animated Head

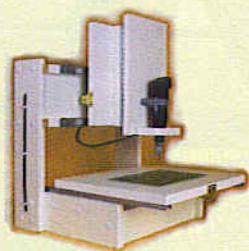

3-Axis Machine



Six-Legged Walkers

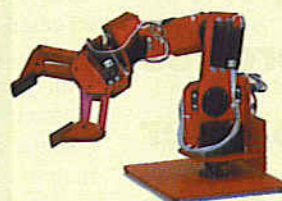

Robotic Arms



Bipeds

Robotic models for both the beginner and the advanced hobbyist

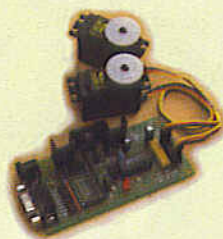

Servo Drivers

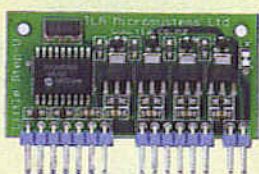

Motor Drivers



On-Screen Displays



DMX Protocol

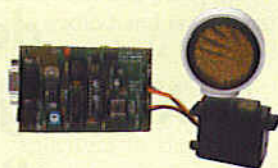

U/Sound Ranging

Animatronics and Specialist Interface-Control Modules



Quadvox MP3 & Speech Systems



SensoryInc Voice Recognition

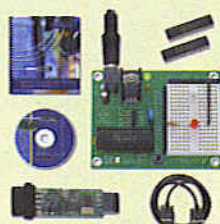

Parallax Ubicom Tool Kits



Tech-Tools PIC & Rom Emulators



BASICMicro PIC BASIC Compilers

Development Tools

Milford Instruments Limited Tel 01977 683665, Fax 01977 681465, sales@milinst.com

Clarity 2x300W

Ton Giesberts

This top-end amplifier proves that high power does not have to mean a large, heavy design. Although this amplifier is highly efficient (and thus compact), its specifications easily surpass those of quite a few conventional designs.

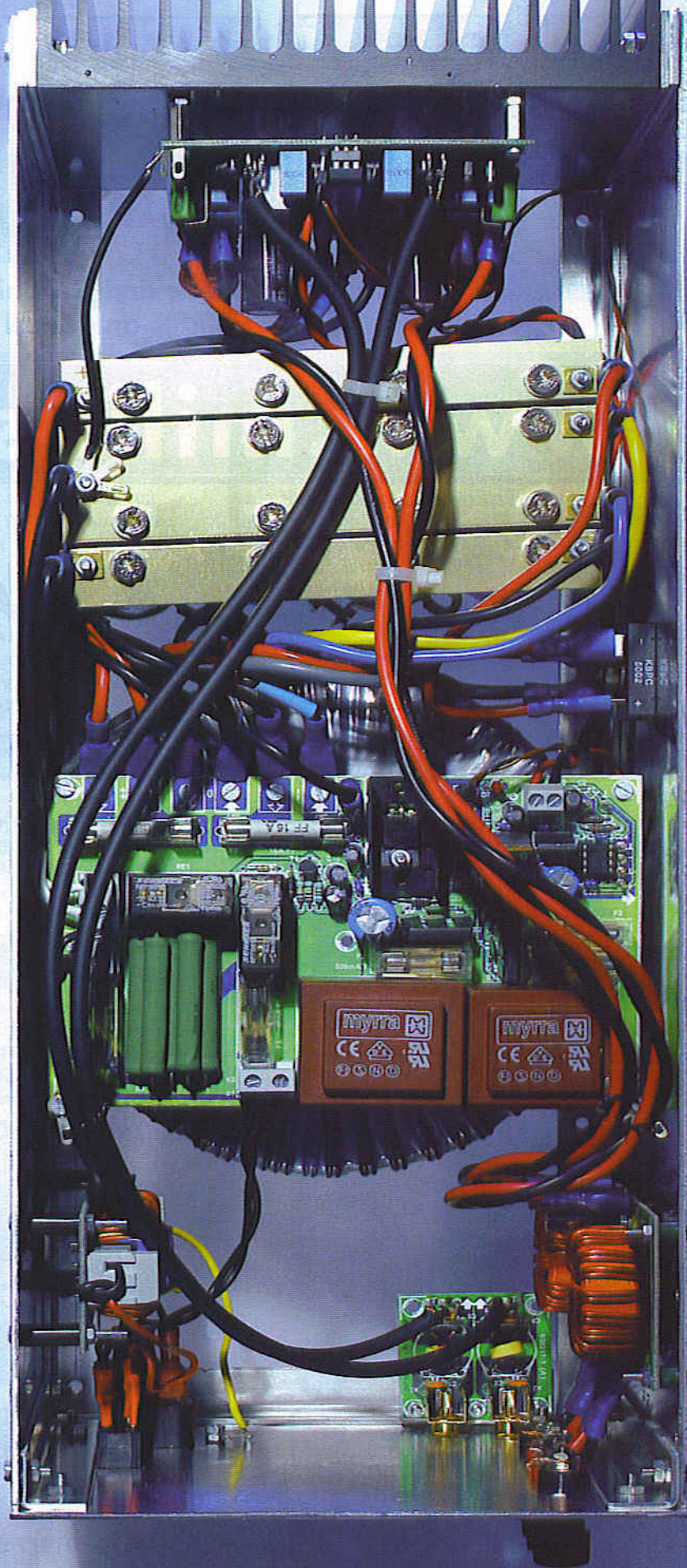

Class-T amplifier

If we've given you the idea that the fully assembled amplifier is as light as a feather, perhaps we should qualify our statement somewhat. After all, 2×300 watts of *true* power naturally requires a rather substantial power supply. But that's the only aspect of this amplifier that is comparable to other types of amplifiers. Thanks to clever use of pulse-width modulation, this amplifier is so efficient that a heat sink with quite modest dimensions can be used, which means that the enclosure can also be kept relatively small. What's more, this amplifier is not an ordinary pulse-width amplifier. This design, which is based on the Tripath TA3020 Class-T digital audio driver, has excellent specifications and can easily hold its own against other top-end amplifiers. For more information about pulse-width modulation in audio final amplifiers, please see the article 'That's class...' elsewhere in this issue. The design is largely based on the standard application example and the manufacturer's reference PCB layout. This is because the board layout largely determines the quality of the overall amplifier. Besides this, the nature of this design (with high switching frequencies and large currents) imposes severe requirements on various components. That means that special types of electrolytic capacitors and decoupling capacitors are used in most locations. Even for the thermal coupling between the output transistors and the heat sink, ordinary mica or Kapton washers are not satisfactory.

Instead, ceramic washers with a thickness of several millimetres must be used. The IC also needs two auxiliary supply voltages, for which a separate printed circuit board has been developed. This board also includes a mains voltage switch-on delay for the main transformer and two hefty fuses for the main supply voltages. To suppress electromagnetic interference (EMC), extra filters are also included at the inputs and outputs. This should already give you an idea of what to expect, but in this first part of the article we primarily concentrate on how the Tripath IC works.

In **Figure 1**, you can clearly see that the IC essentially consists of three sections for each channel: an analogue input stage (inverting amplifier), a processing and modulation unit, and the driver stages (level shifters) for the external power MOSFETs. The IC also provides overcurrent protection, overvoltage and undervoltage protection, and a connection for an external mute signal. All of these collectively determine whether the amplifier outputs are active.

Input stage

The analogue input stage is implemented as an inverting amplifier for convenient dimensioning of the gain and bandwidth. According to the IC specifications, the maximum allowable signal level for fully driving the modulator is $4 V_{pp}$. With the dimensioning used here, assuming an input sensitiv-

ity of $1.13 V_{eff}$ for maximum output amplitude, the output of the input stage can be driven to $3.2 V_{pp}$. The ratio of R3 and R2 (R24 & R23 for the second channel) determines the gain of the input stage. Here the ratio is 1, as can be seen from the schematic diagram in **Figure 2**. Capacitor C2 (C15) increases the stability of the input amplifier and suppresses RF noise by limiting the bandwidth to approximately 240 kHz. C1 (C14) sets the lower corner frequency, which in this case is around 2.5 Hz. The gain for frequencies in the audio band is thus as flat as possible. C1 and C14 are standard MKT capacitors, since as a matter of principle we try to avoid using electrolytic capacitors in the signal path.

R4, R5 and P1, in combination with decoupling capacitor C3 (R25, R26, P2 & C16), allow the output offset voltage of the amplifier to be adjusted to a minimum.

Modulator

The modulator amplifies the signal from the input stage to the output level. It is the second part of the overall amplification, or better said, the actual gain stage. The processor provides a switching waveform that depends on the level and frequency of the signal. With no input signal, the average value of the switching frequency is approximately 700 kHz. It can vary over a maximum range of 200 kHz to 1.5 MHz. Two complementary MOSFET drivers with

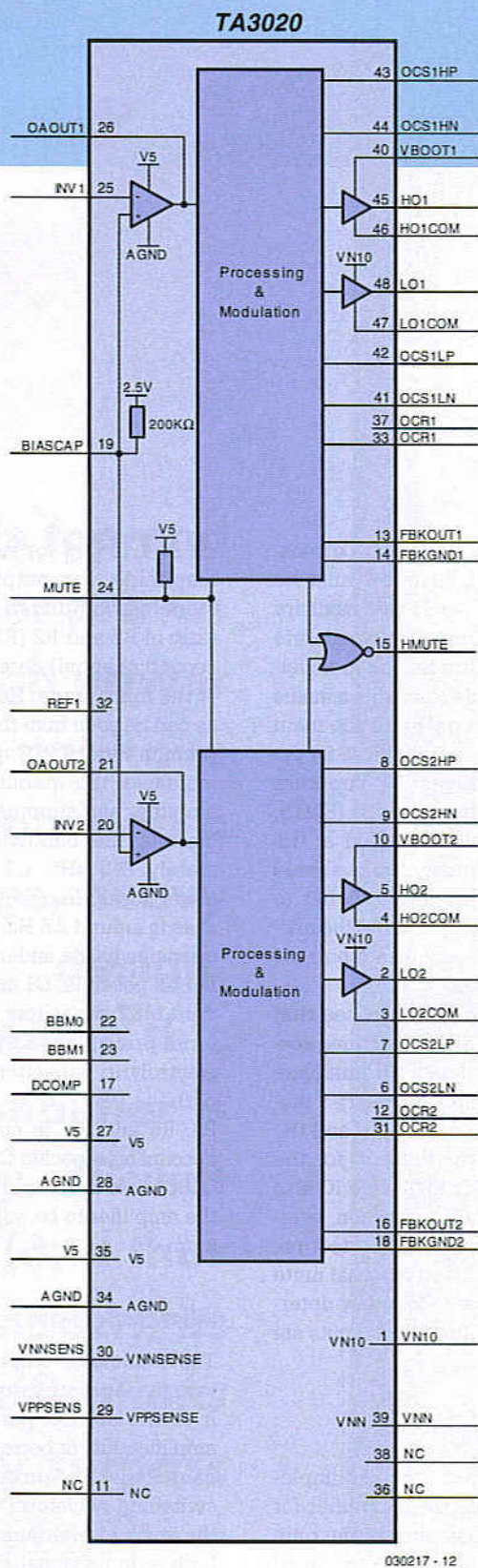

030217 - 12

Figure 1. The internal structure of the Tripath TA3020.

level shifters convert this signal to the proper level for driving the gates of the MOSFETs. The supply voltage for the drivers (10 V) is provided via pin VN10. It is first decoupled as much as possible by C38 and C39. These capacitors must therefore be placed as close as possible to the associated pin of the IC. On the negative side, LO1COM (connected to the source of T2) and VN10 provide the supply connections for the driver. On the positive side, bootstrap capacitor C7 (C20) is charged via D5 (D12) to nearly 10 V when the output is negative, and it 'rides up' on top of the output voltage when T1 starts to conduct. This voltage is fed to VBOOT, which together with HO1COM (the source of T1 is also the bridge output) forms the other supply connection for this driver. At the clipping level, C8 (C21) provides an extra buffer, since the switching frequency is lower at the clipping level. R13 (R14) limits the charging current of C8 (C21) when the amplifier is switched on.

MOSFETs

Two n-channel MOSFETs (T1 & T2 or T3 & T4) form a half-bridge circuit for each channel. The level-shifter outputs alternately drive each of the MOSFETs into conduction. A 'dead time' (break-before-make) is maintained to ensure that the two MOSFETs can never both be conducting at the same time (no 'shoot-through' current). This time can be set using two jumpers (JP1 and JP2). We strongly recommend against experimenting with the selected setting. It might be possible to reduce the dead time if you use MOSFETs with considerably smaller gate capacitance (smaller amplifier power), but certainly not here! Gate resistors R78 and R9 (R28 & R30) limit the slew rate, and thus limit the amount of overshoot due to switching. They also somewhat reduce the amount of power that

would otherwise be dissipated in the drivers (these are 1-W resistors) for charging and discharging the gate capacitances of the MOSFETs. D1 and D2 (D8 and D9) decrease the gate discharge time. This reduces the fall time of the pulses, and thus reduces the chance that both T1 and T2 may both be conducting at the same time. R8 and R10 (R29 & R31) are added for safety reasons. If no IC is fitted, they insure that the gates of the MOSFETs remain discharged. Without these resistors, leakage currents and noise voltages could occasionally have disastrous consequences. R6 and R11 (R27 and R32) are low-inductance resistors that are necessary for current limiting, which is described later on. R12 and C4 (R33 & C7) form a snubber network that eliminates high-frequency spikes in the output signal. This network is thus placed as close as possible to T2 (T4). Diodes D6 and D7 (D13 & D14) are connected between the source and drain of each of the transistors to suppress overshoots. Such overshoots are primarily caused by the coil in the output filter when large currents flow. These diodes (in SMD packages) are also placed as close as possible to the associated leads, primarily to protect the IC. D3 and D4 (D10 & D11) are additional diodes connected between the sources and drains (respectively) of the MOSFETs to suppress overshoots. All of these diodes (D1–D14) must be ultra-fast-recovery types. C5 and C6 (C18 & C19) decouple the half-bridge circuit and are especially included to suppress spikes on the supply voltage lines. This also has a beneficial effect on the operation of the MOSFETs. These capacitors must also be placed as close as possible to the leads of the MOSFETs. C6 (C19) must be an electrolytic capacitor with extremely low ESR and very good HF characteristics. Here you should not use a substitute

for the prescribed type unless its specifications are just as good or better. A normal electrolytic capacitor would probably explode or have a very short life. The pulse-width modulated signal at the output of the half bridge is fed to the output terminals via the LC filter L1/C9 (L2/C22).

Output filter

Thanks to the high switching frequency, here it is only necessary to use a second-order filter with a relatively high corner frequency (resonant frequency 101 kHz). To dampen the Q factor of the filter, which is primarily important if no load is connected, a Zobel network is placed at the output, since otherwise resonance currents and ringing signals at the output could reduce the reliability of the amplifier. As the corner frequency of the filter is higher than for conventional Class D amplifiers, the connected speaker system has a considerably smaller effect. In light of the large currents involved here, an ordinary noise-suppression choke cannot be used for the output filter. A special core material must be used to maintain low distortion and high efficiency. We have more to say on this subject in Part 2 of this article, which will appear in the September 2004 issue.

Amplifier configuration

The gain of the modulator is set using feedback resistor R15 (R36) and voltage divider R18/R20 (R39/R41). These components must be dimensioned according to the value of the supply voltage that is used. This is necessary to make the amplifier independent of the behaviour of the power supply (such as voltage fluctuations due to the output amplitude, mains voltage vari-

ations, etc.). Additional reverse feedback to counter 'ground bounce' is provided by R16 (R37) and voltage divider R17/R19 ((R38/R40). These two networks must be identical! The resistor values can be calculated quite easily. A value of 1 kΩ is generally used for R17 and R18, so the value of the other resistors only depend on the value of the supply voltage VPP (assuming a purely symmetric power supply) and the value selected for R17:

$$R19 = R17 \times VPP \div (VPP - 4)$$

This yields an E96 resistance value of 1.07 kΩ. This value is reasonably independent of the supply voltage. If a maximum supply voltage of 51 V is used, it only increases to 1.10 kΩ. Finally, the value of R15 determines the gain of the modulator:

$$R15 = R17 \times (VPP \div 4)$$

We have assumed a maximum supply voltage of 62 V (the special decoupling electrolytics on the amplifier board are 63-V types). This yields a value of 15.4 kΩ for R15. The gain of the modulator can then be calculated in the same manner as for a standard non-inverting amplifier:

$$A_{\text{modulator}} = (R15 \div R_p) + 1$$

where R_p is the parallel resistance of R18 and R20.

Capacitors C11 and C24 filter and delay the feedback signal to the modulator. They have different values. These capacitors prevent RF noise with very high frequencies from penetrating the feedback network, and using different values causes the modulators to have different switching frequencies. This prevents mutual interference between the modulators. The values are chosen to cause the difference to be greater than 40 kHz.

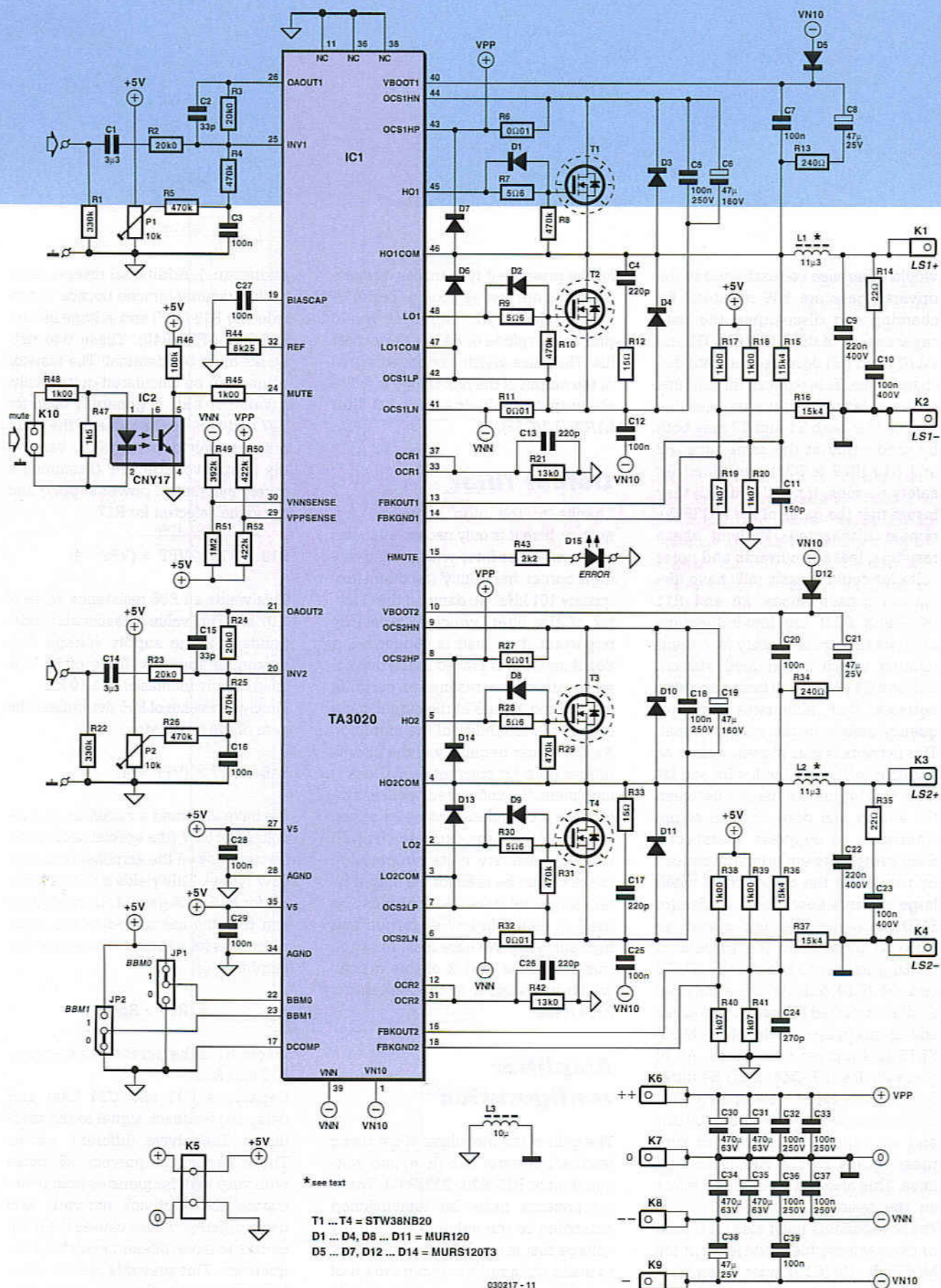

Figure 2. The circuitry around the amplifier IC.

Protection

To protect the amplifier, the driver IC monitors the supply voltages and the currents through the transistors. The VPPSENSE input is used to monitor the main positive supply voltage for over-voltage and undervoltage; the VNNSENSE input is used in the same way for the main negative voltage. If the supply voltage is outside the allowable limits, the output stage is disabled (mute mode). If the supply voltage returns to within the allowable limits, the output is again enabled. For the calculation of the associated component values, please refer to the data sheet. Theoretically, the amplifier could become 'stuck' in situation in which it constantly detects an overvoltage. However, that is very unlikely, since both detection inputs need more than roughly 68 V before they respond. This thus primarily amounts to protection for the IC itself, since several of the power supply capacitors are only rated for 63 V.

The calculations for overcurrent protection are certainly more interesting than those for voltage protection, since they determine the minimum load impedance the amplifier can handle at maximum output power. Since the output stage operates in switch mode, the MOSFETs used in the circuit determine the maximum load capacity of the amplifier. Here we have selected a relatively heavy-duty ST Microelectronics type, the STW38NB20. This transistor, which is housed in a TO-247 package, can handle up to 38 A and has a maximum drain-source voltage of 200 V. The maximum channel resistance with a gate-source voltage (U_{GS}) of 10 V is 0.065Ω ($I_D = 19$ A). A disadvantage of MOSFETs with this sort of specifications is that their input capacitance (C_{iss}) is rather large, in this case as much as 3800 pF. That explains why the drivers in the IC must be able to

deliver rather substantial currents in order to switch the MOSFETs sufficiently quickly. We primarily chose these transistors in order to reduce the risk of unpleasant surprises when using speaker systems with unknown impedances. Naturally, the break-before-make time could be made shorter if transistors with significantly smaller gate capacitance are used, which would reduce the distortion level. However, our choice was in favour of a design that can tolerate low impedances.

Overcurrent detection is provided by the two low-inductance resistors R6 and R11 (R27 & R32), which are connected in series with the transistors as sense resistors. R6 is used for positive half-cycles in series with the drain of T1, while R11 is used for negative half-cycles in series with the source of T2. The response threshold of the protection circuit is set in combination with R21. The IC directly measures the voltages across the sense resistors and uses these voltages to generate a current through R21. The maximum output is determined by comparing the voltage across R21 with the overcurrent threshold voltage V_{TOC} . C13 (C36) filters the voltage from the rectifier. The relationships between these components are given by the following two equations:

$$I_{max} = \frac{3580 \times (V_{TOC} - (I_{bias} \times R21))}{R21 \times R6}$$

$$R21 = \frac{(3580 \times V_{TOC})}{(I_{max} \times R6 + 3580 \times I_{bias})}$$

Here V_{TOC} is the threshold voltage for overcurrent detection (typically 0.97 V) and I_{bias} is 20 μ A.

The first equation can easily be rearranged to allow the component values to be calculated. The second equation can be used to determine the value of R21 (R42). We have chosen a

maximum output current of nearly 20 A, so that a load of somewhat less than 3Ω just avoids triggering the mute mode.

The mute mode can only be reset by briefly switching the level at the Mute input or briefly switching off the amplifier. When the mute mode is active, the HMUTE output is High, and this signal drives a LED that can be fitted to the front panel if desired. A red high-efficiency LED should be used for this purpose, since reducing the value of R43 would overload the output.

Power supply

The supply voltages for the amplifier board are provided by a second printed circuit board. This board includes, among other things, the +5-V and VN10 supplies, as well as fuses for the main supply voltages. It also supplies a delayed 'un-mute' signal that prevents switch-on 'plopping'. To avoid creating an earth loop and prevent ripple currents from flowing through the input stage ground path, the mute signal is fed to the IC via an optocoupler. It is located on the amplifier board. The input of the optocoupler is thus fully isolated from the amplifier, but an active signal is required to switch the amplifier Mute input.

The main supply voltages (VPP and VNN) for the TA3020 are decoupled as well as possible using special electrolytic capacitors (C30, C31, C34 and C35) and MKT capacitors (C32, C33, C36 and C37). A simple decoupling network is used for the 5-V supply voltage for the input amplifiers.

To suppress possible interference from the output circuit as well as possible, analogue ground and modulator ground (which is also the ground for the rest of the circuit) are kept separate and coupled on the solder side of the board at a single location using an SMD inductor.

Layout

As already mentioned at the beginning of the article, the amplifier relies on a carefully designed layout. The layout thus forms an essential part of the overall amplifier. Tripath emphatically recommends copying the reference layout, since otherwise the large high-frequency currents could give rise to unexpected effects. Naturally, some of the components we have selected differ from those used on the reference board, primarily with regard to their dimensions. This is because we have given special attention to the availability of the components (preferably in single quantities). Some of the tracks have been shifted slightly in some places, and a few components have been added, but by and large we still succeeded in maintaining the recommended layout. If you take the trouble to look at the photo of the reference

board in the data sheet, you will see the resemblance to the photos of the prototype. For some of the components shown in the schematic that are fitted on the solder side of the board in the Tripath layout, we have put them on the component side instead. This is why the circuit board is placed parallel to the heat sink in our version, with the transistors mounted below the board. This produces an attractively compact and robust module, but we'll save further comments for the construction description in the second part of the article. What we can tell you already is that although the module looks very simple at first glance, on closer examination you will notice that compared with the schematic, a few things seem to be missing. Many of the components are SMD types, and they are fitted on the solder side of the board. This yields the lowest likelihood

of interference problems and results in an amplifier board with very modest dimensions for a 2 x 300 W amplifier. Most of these SMD devices come in 0603 'shapes', which in all honesty are nasty little things to work with. To make things easier for you, we will try to supply the circuit board in the near future with the SMD components already fitted.

In the second part of this article (September 2004 issue), we give detailed attention to the construction of this unusual amplifier.

(030217-1)

Web pointers

TA3020 data sheets & application note:
www.tripath.com/downloads/TA3020.pdf
TA3020 reference board --
www.tripath.com/downloads/RB-TA3020.pdf

See your design in print!

Elektor Electronics (Publishing)

are looking for

Freelance Technical Authors/Designers

If you have

- * an innovative or otherwise original design you would like to see in print in Europe's largest magazine on practical electronics
- * above average skills in designing electronic circuits
- * experience in writing electronics-related software
- * basic skills in complementing your design with an explanatory text
- * a PC, email and Internet access for efficient communication with our in-house design staff

then do not hesitate to contact us for exciting opportunities in getting your designs published on a regular basis.

Elektor Electronics

K. Walraven, Head of Design Dept.

P.O. Box 75, NL-6190-AB Beek, The Netherlands, Fax: (+31) 46 4370161

Email: k.walraven@segment.nl

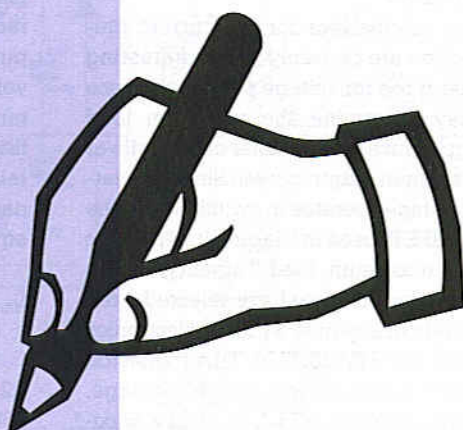

Visit our website
www.distel.co.uk

THE ORIGINAL SURPLUS WONDERLAND!

THIS MONTH'S SELECTION FROM OUR VAST EVER CHANGING STOCKS

Surplus always
wanted for cash!

GIANT 10" 7 SEGMENT DISPLAYS

A bulk purchase enables us to bring to you these GIANT 10" segment digital displays at a new affordable price! The 10" character size gives exceptional readability at long distances and enables a host of applications including score boards, digital clocks, counters, event timers etc. As the units are a simple electro-mechanical device and operate from 12V DC, simple switching via switches, relays, PIC or PC may be used to control single or multiple digits. Units feature integral 'Zero Power' memory which greatly simplifies design. For an excellent DIY practical article, see the May issue of 'Everyday & Practical Electronics' magazine. Ideal School / College construction project. Supplied in good RFE condition, complete with data sheet.



Less than 30% of makers price! Only £29.95(B) or 4 / £99.00(D) of makers price!

THE AMAZING TELEBOX



TV SOUND & VIDEO TUNER
CABLE COMPATIBLE*

Converts your colour monitor into a QUALITY COLOUR TV!

The TELEBOX is an attractive fully cased mains powered unit, containing all electronics ready to plug into a host of video monitors or AV equipment which are fitted with a composite video or SCART input. The composite video output will also plug directly into most video recorders, allowing reception of TV channels not normally receivable on most television receivers (TELEBOX MB). Push button controls on the front panel allow reception of 8 fully tunable off air UHF colour television channels. TELEBOX MB covers virtually all television frequencies VHF and UHF including the HYPERBAND as used by most cable TV operators. Ideal for desktop computer video systems & PIP (picture in picture) setups. For complete compatibility - even for monitors without sound - an integral 4 watt audio amplifier and low level Hi Fi audio output are provided as standard. Brand new - fully guaranteed.

TELEBOX ST for composite video input type monitors £36.95
TELEBOX STL as ST but fitted with integral speaker £39.50
TELEBOX MB Multiband VHF/UHF/Cable/Hyperband tuner £59.95
For overseas PAL versions state 5.6 or 6 MHz sound specification.
*For cable / hyperband signal reception Telebox MB should be connected to a cable type service. Shipping on all Teleboxes, code (B)

NEW State of the art PAL (UK spec) UHF TV tuner module with composite 1V pp video & NICAM Hi fi stereo sound outputs. Micro electronics all on one small PCB only 73 x 160 x 52 mm enable full tuning control via a simple 3 wire link to an IBM pc type computer. Supplied complete with simple working program and documentation. Requires +12V & +5V DC to operate. **BRAND NEW - Order as MY00. Only £39.95 code (B)**
See www.distel.co.uk/data_my00.htm for picture + full details

HARD DISK DRIVES 2 1/2" - 14"

2 1/2" TOSHIBA MK1002MAV 1.1Gb laptop (12.5 mm H) New £59.95
2 1/2" TOSHIBA MK4313MAT 4.3Gb laptop (8.2 mm H) New £105.00
2 1/2" TOSHIBA MK6409MAV 6.1Gb laptop (12.7 mm H) New £98.00
2 1/2" TOSHIBA MK1814GAV 1.8 Gb laptop (1.2 mm H) New £149.95
2 1/2" to 3 1/2" conversion kit for PCs, complete with connectors. £15.95
3 1/2" COMPAQ 315706-B21 (IBM) 5 gb ULS/SCSI New £199.00
3 1/2" FUJI FK-309-28 20mb MFM I/F RFE £59.95
3 1/2" CONNER CP3024 20 mb IDE I/F (or equiv.) RFE £59.95
3 1/2" CONNER CP3044 40 mb IDE I/F (or equiv.) RFE £69.00
3 1/2" QUANTUM 40S Prodrive 42mb SCSI I/F, New RFE £49.00
3 1/2" MINISCRIBE 3425 20mb MFM I/F (or equiv.) RFE £49.95
5 1/4" SEAGATE ST-238R 30 mb RLL I/F Refurb £69.95
5 1/4" CDC 94205-51 40Mb HH MFM I/F RFE tested £69.95
5 1/4" HP 97548 650 Mb SCSI RFE tested £99.00
5 1/4" HP C3010 2 Gbyte SCSI differential RFE tested £195.00
8" NEC D2246 85 Mb SMD interface. New £99.00
8" FUJITSU M23222 160MB SMD I/F RFE tested £195.00
8" FUJITSU M2392K 2 Gb SMD I/F RFE tested £345.00
Many other floppy & H drives, IDE, SCSI, ESDI etc from stock, see website for full stock list. Shipping on all drives is code (C)

IC's - TRANSISTORS - DIODES

OBSOLETE - SHORT SUPPLY - BULK
10,000,000 items EX STOCK
For MAJOR SAVINGS
CALL or see web site www.distel.co.uk
COMPUTER MONITOR SPECIALS

Legacy products
High spec genuine multisync.
CGA, EGA, VGA, SVGA

Mitsubishi FA3415ETKL 14" SVGA Multisync colour monitor with fine 0.28 dot pitch tube and resolution of 1024 x 768. A variety of inputs allows connection to a host of computers including IBM PC's in CGA, EGA, VGA & SVGA modes. BBC, COMMODE (including Amiga 1200), ARCHIMEDES and APPLE. Many features: Etched faceplate, test switching and LOW RADIATION MPR specification. Fully guaranteed, in EXCELLENT little used condition. Tilt & Swivel Base £475

VGA cable for IBM PC included. Only £129 (E) Order as CG73
External cables for other types of computers available - CALL

Generic LOW COST SVGA Monitors
We choose the make, which includes Compaq, Mitsubishi, IBM, etc. Supplied ready to run with all cables, Standard RTB 90 day guarantee.

14" £59.00 order TD84	15" £69.00 order TG21	17" £79.00 order TJ66
-----------------------------	-----------------------------	-----------------------------

Supplied in good used condition. Shipping code (D)

VIDEO MONITORS

PHILIPS HC535 (same style as CM8833) attractively styled 14" colour monitor with both RGB and standard composite 15.625 KHz video inputs via SCART socket and separate phono jacks. Integral audio power amp and speaker for all audio visual uses. Will connect direct to Amiga and Atari BBC computers. Ideal for all video monitoring / security applications with direct connection to most colour cameras. High quality with many features such as front concealed flap controls, VCR correction button etc. Good used condition - fully tested - guaranteed
Dimensions: W14" x H12 1/2" x 15 1/2" D.
Only £99.00 (D)

PHILIPS HCS31 Ultra compact 9" colour video monitor with standard composite 15.625 KHz video input via SCART socket. Ideal for all monitoring / security applications. High quality, ex-equipment fully tested & guaranteed (possible minor screen burn). In attractive square black plastic case measuring W10" x H10" x 1 3/8" D. 240 V AC mains powered.
Only £79.00 (D)

INDUSTRIAL COMPUTERS

Tiny shoebox sized industrial 40 Mhz 386 PC system measuring only (mm) 266 x X 88 h X 272 d. Ideal for dedicated control applications running DOS, Linux or even Windows! Steel case contains 85 to 265 V AC 50 / 60 Hz 70 Watt PSU, a 3 slot ISA passive backplane and a Rocky 318 (PC104) standard, single board computer with 8 MByte NON VOLATILE solid state 'Disk On Chip' RAMDISK. System comprises: Rocky 318 (PC104) SBC ISA card with 40MHz/4L 386SX CPU, 72 pin SIMM slot with 16 MByte SIMM, AMI BIOS, battery backed up real time clock, 2 x 9 pin D 16550 serial ports, EPP/ECP printer port, mini DIN keyboard connector, floppy port, IDE port for hard drives up to 528 MByte capacity, watchdog timer and PC104 bus socket. The 8 MByte solid state 'disk on chip' has its own BIOS, and can be formatted, formatted & booted. Supplied BRAND NEW fully tested and guaranteed. For full data see featured item on website. Order as GQ36
100's of applications inc: firewalls, routers, robotics etc
Only £99.00 (D)

Unless marked NEW, items in this section are pre-owned.

TEST EQUIPMENT & SPECIAL INTEREST ITEMS

MITSUBUSHI FA3445ETKL 14" Ind. spec SVGA monitors £245
FARNELL 0-60V DC @ 50 Amps, bench Power Supplies £995
FARNELL AP3080 0-30V DC @ 80 Amps, bench Supply £1850
KINGSHILL C2403/1 0-50V DC @ DC 200 Amps - NEW £3950
1kW to 400 kW - 400 Hz 3 phase power sources - ex stock EPOA
IBM 8230 Type 1, Token ring base unit driver £760
Wayne Kerr RA200 Audio frequency response analyser £2500
INFODEC 1U, 24 port, RJ45 network patchpanels. #TH93 £49
3COM 16670 12 Port Ethernet hub - RJ45 connectors #LD97 £59
3COM 16671 24 Port Ethernet hub - RJ45 connectors £59
3COM 16700 8 Port Ethernet hub - RJ45 connectors NEW £39
IBM 535591 Token Ring ICS 20 port lobe modules EPOA
IBM MAU Token ring distribution panel 6223-23-5050N £45
AIM 501 Low distortion Oscillator 9Hz to 330KHz, IEEE I/O £59
ALLCON 8360.11805-1880 MHz hybrid power combiners £250
Trend Data 274 Data Analyser with G703(ZM) 84 I/O EPOA
Marconi 6310 Programmable 2 to 22 GHz sweep generator £4500
Marconi 2022C 10KHz-1GHz RF signal generator £1750
HP1650B Logic Analyser £3550
HP3781A Pattern generator & HP3782A Error Detector EPOA
HP6621A Dual Programmable GPIB PSU 0-7 V 160 watts £1800
HP6264 Rack mount variable 0-20V @ 20A metered PSU £475
HP54121A DC to 22 GHz four channel test set EPOA
HP8130A opt 020 300 MHz pulse generator, GPIB etc £7900
HP A1, A0 6 pen HPGL high speed drum plotters - from £550
HP DRAFTMASTER 1 8 pen high speed plotter £750
EG+G Brookdeal 95035C Precision lock in amp £1800
Keithley 590 CV capacitor / voltage analyser EPOA
Racal ICR40 dual 40 channel video recorder system £3750
Fiskers 45KVA 3 ph On Line UPS - New batteries £4500
Emerson AP130 2.5KVA industrial spec UPS £1499
Mann Tally MT645 High speed line printer £2200
Intel SBC 486/133SE Multibus 488 system, 8Mb Ram £945

HP6030A 0-200V DC @ 17 Amps bench power supply £1950
Intel SBC 486/1250C Enhanced Multibus (MSA) New £1150
Nikon HPX-11 (Ephiphot) exposure control unit £1450
PHILIPS PM5518 pro. TV signal generator £1250
Motorola VME Bus Boards & Components List. SAE / CALL EPOA
Trio 0-18 vdc linear, metered 30 amp bench PSU. New £550
Fujitsu M3041R 600 LPM high speed band printer £1950
Fujitsu M3041D 600 LPM printer with network interface £1250
Siemens K4400 64Kb to 140Mb bus analyser £2950
Perkin Elmer 299B Infrared spectrophotometer £3500
Perkin Elmer 597 Infrared spectrophotometer £3250
Vg Electronics 1035 TELETEXT Decoding Margin Meter £495
LightBand 60 output high spec 2u rack mount Video VDA's £1985
B&K 2633 Microphone pre amp £300
Taylor Hobson Talysurf amplifier / recorder £750
ADC SS200 Carbon dioxide gas detector / monitor £1450
BBC AM203 PPM Meter (Ernest Turner) + drive electronics £75
ANRITSU 9654A Optical DC-2.5G/b waveform monitor £5650
ANRITSU ML93A optical power meter £990
ANRITSU Fibre optic characteristic test set EPOA
R&S FTDZ Dual sound unit £650
R&S SBUF-E1 Vision modulator £775
WILTRON 6630B 12.4 / 20GHz RF sweep generator £5750
TEK 2445 150 MHz 4 trace oscilloscope £1250
TEK 2465 300 MHz 300 MHz oscilloscope rack mount £1955
TEK TDS380 400MHz digital realtime + disk drive, FFT etc £2900
TEK TDS524A 500MHz digital realtime + colour display etc £5100
HP3585A Opt 907 20Hz to 40 Mhz spectrum analyser £3950
PHILIPS PW1730/10 60KV XRAY generator & accessories EPOA
VARIACS - Large range from stock - call or see our website £3250
CLAUDE LYONS 12A 240V single phase auto. volt. regs £3250
CLAUDE LYONS 100A 240/415V 3 phase auto. volt. regs £2900

19" RACK CABINETS

Save £££'s
Europe's Largest Stocks of quality rack cabinets, enclosures and accessories.
Over 1000 Racks from stock

This month's special
33 / 42 / 47 U - High Quality
All steel Rack Cabinets

Made by Eurocraft Enclosures Ltd to the highest possible spec, rack features all steel construction with removable side, front and back doors. Front and back doors are hinged for easy access and all lockable with five secure 5 lever barrel locks. The front door is constructed of double wall steel with a 'designer style' smoked acrylic front panel to enable status indicators to be seen through the panel, yet remain unobtrusive. Internally the rack features fully slotted reinforced vertical fixing members to take the heaviest of 19" rack equipment. The two movable vertical fixing struts (extras available) are pre-punched for standard 'cage nuts'. A mains distribution panel internally mounted to the bottom rear, provides 6 x IEC 3 pin Euro sockets and 1 x 13 amp 3 pin switched utility socket. Overall ventilation is provided by fully louvered back door and double skinned top section with top and side louvres. The top panel may be removed for fitting of Integral fans to the sub plate etc. Other features include: fitted castors and floor levelers, pre-punched utility panel at lower rear for cable / connector access etc. Supplied in excellent, slightly used condition with keys. Colour Royal blue, some grey available - CALL - Can be supplied in many other configurations.



33U Order as BC44 External dimensions mm=1625H x 635D x 603 W. (64" H x 25" D x 23 3/4" W) Only £245	42U Order as DT20 External dimensions mm=2019H x 635D x 603 W. (79.5" H x 25" D x 23 3/4" W) Only £345	47U Order as RV36 External dimensions mm=2235H x 635D x 603 W. (88" H x 25" D x 23 3/4" W) Only £410
--	--	--

Call for shipping quotation

COLOUR CCD CAMERAS

Undoubtedly a miracle of modern technology & our special buying power! A quality product featuring a fully cased COLOUR CCD camera at a give away price! Unit features full autogain sensing for use in low light & high light applications. A 10 mm fixed focus wide angle lens gives excellent focus and resolution from close up to long range. The composite video output will connect to any composite monitor or TV (via SCART socket) and most video recorders. Unit runs from 12V DC so ideal for security & portable applications where mains power not available. Overall dimensions 66 mm wide x 117 deep x 43 high. Supplied BRAND NEW & fully guaranteed with user data, 100's of applications including Security, Home Video, Web TV, Web Cams etc.
Order as LK33 ONLY £79.00 or 2 for £149.00 (B)



SOFTWARE SPECIALS

NT4 WorkStation, complete with service pack 3 and licence - OEM packaged. ONLY £89.00 (B)
ENCARTA 95 - CDROM, Not the latest - but at this price! £7.95
DOS 5.0 on 3 1/2" disks with concise books c/w QBasic £14.95
Windows for Workgroups 3.11+ Dos 6.22 on 3.5" disks £55.00
Windows 95 CDROM Only - No Licence - £19.95
Wordperfect 6 for DOS supplied on 3 1/2" disks with manual £24.95
shipping charges for software is code B

SOLID STATE LASERS

Visible red, 670nm laser diode assembly. Unit runs from 5 V DC at approx 60 mA. Originally made for continuous use in industrial barcode scanners, the laser is mounted in a removable solid aluminium block, which functions as a heatsink and rigid optical mount. Dims of block are 50 w x 50 d x 15 h mm. Integral features include over temperature shutdown, current control, laser OK output, and gated TTL ON / OFF. Many uses for experimental optics, comms & lightshows etc. Supplied complete with data sheet.
Order as TD91 ONLY £24.95 (A)

DC POWER SUPPLIES

Virtually every type of power supply you can imagine. Over 10,000 Power Supplies
Ex Stock - Call or see our web site.

RELAYS - 200,000 FROM STOCK

Save ££££'s by choosing your next relay from our Massive Stocks covering types such as Military, Octal, Cradle, Hermetically Sealed, Continental, Contactors, Time Delay, Reed, Mercury Wetted, Solid State, Printed Circuit Mounting etc. CALL or see our web site www.distel.co.uk for more information. Many obsolete types from stock. Save ££££'s

DISPLAY ELECTRONICS

ALL MAIL TO
Dept EK, 29 / 35 Osborne Rd
Thornton Heath
Surrey CR7 8PD, UK
Open Mon - Fri 9.00 - 5:30

18 Million Items On Line Now!
Secure Ordering, Pictures, Information
VeriSign
www.distel.co.uk
email = admin@distel.co.uk

ALL ENQUIRIES
0208 653 3333
FAX 0208 653 8888



All prices for UK Mainland. UK customers add 17.5% VAT to TOTAL order amount. Minimum order £10. Bona Fide account orders accepted from Government, Schools, Universities and Local Authorities - minimum account order £100. Cheques over £100 are subject to 7 working days clearance. Carriage charges (A)=£3.50, (B)=£5.50, (C)=£10, (D)=£15.00, (E)=£18.00, (F)=CALL. Allow approx 3 days for shipping - faster CALL. All goods supplied to our Standard Conditions of Sale which can be viewed at our website and unless stated guaranteed for 90 days. All guarantees on a return to base basis. All rights reserved to change prices / specifications without prior notice. Orders subject to stock. Discounts for volume. Top CASH price paid for surplus goods. All trademarks, tradenames etc acknowledged. © Display Electronics 2002. E & O E.



Paul Goossens

Design Your Own IC

Part 2: CPLDs in practice

Following the description of the hardware in last month's issue (Part 1), it's now time to start working with the experimenter's board.

We assume that you have already installed the Altera software and read the tutorial.



Designing digital circuits usually amounts to repeatedly breaking down the problem into subproblems until you finally arrive at a design consisting of variety of basic logic functions. Based on this, you can develop the electronic circuit and, if necessary, a printed circuit board.

Descriptive languages

Designing digital logic circuitry is easier if you use a descriptive language. The purpose of such a language is to allow specific functions to be described (hence the name). A descriptive language allows intelligent software to be used to design an electronic circuit that meets the description specified by the designer. There are presently several different descriptive languages. Two of them are manufacturer-independent and are supported by a large number of manufacturers: Verilog and VHDL. In this article, we use Verilog as our descriptive language.

Verilog

We chose Verilog because it is somewhat clearer than VHDL. However, the two languages are the same in many aspects. The biggest difference between them is in how the descriptions are formulated. This means that many of the considerations, pitfalls and the like described in this article are also directly applicable to VHDL. It's possible to generate hierarchical designs using Verilog. This means that the design can be divided into smaller designs. These smaller 'subdesigns' can in turn be further divided into various subdesigns as necessary. In Verilog parlance, such subdesigns are called 'modules'.

Dividing a design into several modules

has the beneficial side effect that it may be possible to reuse the modules in other designs. A counter is an example of a type of module that is used relatively often, so it is definitely a good idea to put a counter into a separate module.

Example 1

The best way to learn something is by actually doing it. Consequently, we can begin right away with an example. Before you can get started, you must download the examples from the Elektor Electronics Internet site (www.elektor-electronics.co.uk). The examples are located under item number 030385-11 for the June articles. All you have to do is unpack the Zip file. Example 1 can be found in the *Ex1* folder. Just double-click on the *ex1.quartus* file, and the design software will start up automatically. In the schematic diagram that is displayed, you can see that the various I/O pins of the IC are connected to a block in which several signals are listed. These signals are the inputs and outputs of this block.

As you have already seen in the tutorial (you did look at the tutorial, didn't you?), you can view the associated source code by double-clicking on the block. In this case, the source code is written in the Verilog language. The text shown in green is all comments as far as Verilog is concerned, so it has no effect on the ultimate result. However, Quartus uses these lines to store information, so it's a good idea to leave them as they are.

Structure

Verilog source code is always organised using the same structure. It starts with the module declaration. This part of the code begins with the word 'module', followed by a name. This is

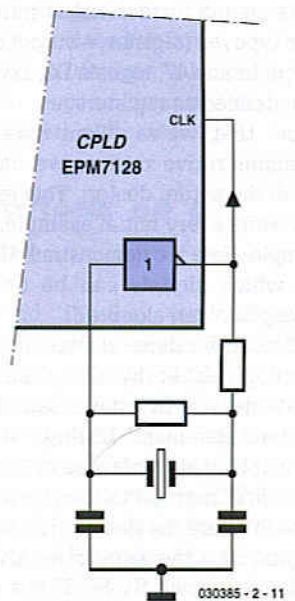

Figure 1. Schematic diagram of a standard crystal oscillator.

accompanied by a collection of inputs and outputs in brackets, separated by commas. The whole thing is terminated by a semicolon. This can be seen in lines 30–35 of our example.

The next thing you have to do is to define the directions of the signals (ports) identified in the module declaration. You can see how this is done in lines 39–45 of our example. There are three options for each signal: *input*, *output*, or *inout* (bi-directional). Here we have only used 'input' and 'output'. Each line is terminated by a semicolon (;). In the first line, you can see that several signals can be defined in a single line if commas are used to separate the definitions.

The outputs require an additional specification. If the function of an output is described in a procedural statement (don't worry, we'll explain what

Table 1. Boolean functions

&	=	AND
~&	=	NAND
	=	OR
~	=	NOR
~	=	NOT
^	=	XOR
~^	=	XNOR

Table 3. Arithmetic operators

+	=	add
-	=	subtract
*	=	multiply
/	=	divide
%	=	modulo

Table 3. Relational operators

>	=	greater than
>=	=	greater than or equal to
<	=	less than
<=	=	less than or equal to
=	=	equal to
!	=	not equal to

this means further on), it must have the type *reg* (register = output of a flip-flop). In line 47, signals D2, D3 and D4 are defined as registers.

Now that we've taken care of the administrative duties, we can start with the actual design. This example, as befits every initial example, is very simple. Here we demonstrate the ways in which signals can be described using Boolean algebra.

This can be done in two manners in Verilog: either by using an *assign* statement, or in what is called a 'procedural statement'. **Listing 1** shows an example of each of these methods.

The first method is demonstrated in line 50. Here the description says that signal D1 is the result of an AND operation on signals S1-S4. That's another way of saying that D1 is only active if S1-S4 are also active ('1'). In all other cases, D1 is inactive ('0').

The symbol '&' thus stands for the AND function. The Boolean functions in Verilog are summarised in **Table 1**.

Procedural statements

The remaining outputs (D2-D4) are described in a procedural statement. Procedural statements are always preceded by the word *always*. This keyword is described in more detail in one of our later examples.

Just as in the Pascal programming language, you can combine a group of statements into a unit by using the keywords *begin* and *end*. All of the statements between these two words are collectively regarded as being a single statement.

If you look at line 54, you will see that signal D4 is described as a signal that becomes active if S1 or S2 or S3 or S4 is active. Here we intentionally used the word 'becomes' instead of 'is'. The symbol *<=* means 'becomes' or

'assumes the value'. As a general rule, we can say that this symbol is used in a procedural statement instead of the = sign.

It's not difficult to figure out the functions of signals D3 and D4 if you use **Table 1** for a bit of help.

The advantage of putting signals in procedural statements instead of working with *assign* statements will become clear in a later example.

Finally, the keyword *endmodule* indicates that the description of the module is finished.

Compiling

Now we're getting close to the point where you have to roll up your sleeves and get to work. First, the design has to be compiled. The compiler already knows exactly which signal must be connected to each pin of the CPLD. That's because we already did this for you. This makes compiling child's play; just click on *Start Compilation* in the *Processing* menu and the software goes into action.

Various messages will be shown on the screen, and several progress bars will move along. After a while, the program will report that the compilation was successful. That means it has created a programming file that you can use to program your IC.

Programming

As already mentioned in Part 1 of this article, to program the CPLD you will need the JTAG programmer described in the September 2002 issue of *Elektor Electronics*. Of course, an original Altera ByteBlaster is also OK. We assume that your programmer is connected to the printer port of the PC and the JTAG connector is attached to connector K2 of the experimenter's board. Now switch on the power for the experimenter's board.

In Quartus, first select the *Tools* menu and then *Programmer*. A new window will appear. Check that the programmer is set to 'JTAG' and the correct interface (ByteBlaster) is selected.

In this window, there is a line that has 'EPM7128SLCM' in the *Device* column. On the same line, the programming file *ex1.pof* is shown in the *File* column. Everything is now ready for programming the CPLD. You must tell the program you want to program this IC by placing a tick mark under the *Program/Configure* column.

Finally, click on the *Start Programming* button, which is located at the very top and looks like a sort of 'Play' button.

Testing

After being programmed, the CPLD is immediately active, which means that the programmed design can be used right away. Make sure that jumpers JP1 and JP2 are fitted.

Checking the design is easy. LED D1 should only be on if all of the switches are in the '1' position. In all other cases, the LED must be dark. By contrast, LED D4 should do just the opposite. That means that if D1 is on, D4 must be off, and vice versa.

We have described D2 as an OR function, which means that this LED must be on if one or more switches are in the '1' position.

LED D3 must light up whenever S1 and S2 are both in the '1' state OR S3 and S4 are both in the '1' state. These functions can be easily checked using the switches.

Now try to modify the design in Quartus to cause LED D1 to be on whenever S1 is in the '1' state and S2 is in the '0' state. The states of the other switches don't matter. Good luck with your design!

Listing 1. Boolean algebra

```
50 assign D1 = S1 & S2 & S3 & S4;
51
52 always
53 begin
54     D2 <= S1 | S2 | S3 | S4;
55     D3 <= ( S1 & S2 ) | ( S3 & S4 );
56     D4 <= ~(S1 & S2 & S3 & S4);
57 end
```

Example 2

As already mentioned, Example 1 is very simple. The special power of Verilog is that it allows designers to develop designs in a more descriptive manner. Boolean algebra can occasionally be handy in Verilog, but it is certainly not the intention that relatively complex designs must be entered entirely in Boolean algebra. This can be demonstrated using Example 2, in which we set about designing two flip-flops and a latch.

The files for Example 2 can be found in the *ex2* folder. In this folder, open *ex2.quartus*, and the program will automatically open all of the other necessary files.

In the schematic diagram (*ex2.bdf*), you can see that switches S1-S4 are connected to a functional block named *flipflop*. S1 is connected to the CLK input, etc. Double-click on the block to open the associated Verilog source code.

Always @

Up to line 46, there's nothing new to be seen. But in line 46 you can see something added to the keyword *always*: an @ character followed by a comparison. This code segment can also be seen in Listing 2. The @ sign indicates that the procedural statements belonging to this *always* statement are only allowed to be evaluated (but not 'executed'; only processors execute statements) if the following comparison is satisfied. In this case, that means that the following statements are only applicable at the moment when the clock signal (CLK) OR the reset signal OR the SET signal has a rising edge (*posedge*). Just to avoid any confusion, a rising edge is the transition from a Low level to a High level.

Verilog also has the modifier '*negedge*', which in normal English means '*negative edge*' or '*falling edge*'.

If any one of these conditions is satisfied, this section of the code is evaluated. First, a check is made to see whether the RESET signal is '1'. If this is the case, OUT becomes inactive ('0') and this code segment is done. Otherwise, a check is made to see whether the SET signal is '1'. If it is, the OUT output goes to '1' and the code is done. Beside the values '1' and '0', each signal can also assume the values 'x' (unknown) or 'z' (high impedance). If neither RESET nor SET is '1', CLK must have a rising flank, since otherwise this code would not have been evaluated. The intention is that on the rising edge of the clock signal, the output of the flip-flop assumes the value present at the input.

But what happens to the output whenever there isn't a rising edge on CLK, RESET or SET? The answer is very simple: nothing. In line 45, the OUT signal is defined to be a register, which means that the value most recently assigned to this signal must be held. Whenever the code is not active, the value of this register will not change. By adding the '@' character to the *always* statement, we can thus indicate the conditions under which a portion of the code is allowed to be evaluated. During the rest of the time, the output that is controlled by this block must remain the same.

From the code, it can clearly be seen that the RESET input has higher priority than the SET input. However, that doesn't mean that the CPLD evaluates these two signals one after the other when it is operating. The CPLD will respond just as fast to the RESET signal as to the SET signal. The sequence is only important for the compiler. It evaluates a section of code and determines what must happen to the output

for every imaginable combination of input signals. Based on this evaluation, the compiler 'designs' a bit of digital logic that respond in exactly the manner described in the code.

Variations on a theme

A second flip-flop (appropriately named 'flipflop2') is also shown in the schematic diagram (*ex2.bdf*). The associated Verilog file is very similar to the file for the first flip-flop. The only difference with respect to the first flip-flop is that the state of the SET signal is checked before the state of the RESET signal. That means that for this flip-flop, the SET input has a higher priority than the RESET input. The output will thus go to '1' if the RESET and SET inputs both have a value of '1'. With the first flip-flop, the output will go to '0' in this situation.

Latch

The final block in the schematic is a latch. A latch is also a frequently used type of component in digital designs. The operation of a latch is actually quite simple. As long as the clock input is '1', the latch's output must be the same as its input. If the input state changes, the output must immediately follow the change. By contrast, if the clock signal is inactive ('0'), the last known state of the output must be retained, regardless of any changes to the input state.

The Verilog file *latchexample.v* shows how this can be described in the Verilog language. The output signal can change if the state of the clock signal changes OR the state of the data input changes. This can happen on the rising edge as well as on the falling edge. After the @ sign you can see '(posedge CLK or D)'. What's special about this is

Listing 2. A clocked flip-flop

```
46 always @ (posedge CLK or posedge RESET or posedge SET)
47 begin
48   if (RESET)
49     OUT <= 1'b0;
50   else if (SET)
51     OUT <= 1'b1;
52   else
53     OUT <= D;
54 end
```

that signal D is named without 'posedge' in front. This means that the code must be evaluated for every change in the state of signal D.

In the code belonging to this *always* statement, you can see that the compiler first looks at the state of the clock signal. If the clock signal is active ('1'), the output is the same as the input. Otherwise nothing happens, and the current state of the output remains unchanged.

You can compile this example and program it into the CPLD in exactly the same manner as for the previous example. After doing so, use the experimenter's board to verify that the design actually does what you expect it to do. After this, as an exercise you can see whether you can provide the latch with SET and RESET inputs. As the saying goes, practice makes perfect!

Arithmetic

The previous examples demonstrate how to describe functions without having to worry about logic gates, Boolean algebra and so on. After working with Verilog with a while, every designer will certainly be able to appreciate this. The relatively trivial tasks are handled by the compiler instead of the designer. Our third example shows that arithmetic is also not difficult in Verilog. In this example we use counters. Counters need clock signals, and that's where we start.

Figure 1 shows the schematic diagram of a standard crystal oscillator. Except for the inverter, all of the components are present on the experimenter's board. If we now place an inverter between pins 71 and 81 of the CPLD, we have a crystal oscillator.

If you open Example 3, you will see this inverter drawn between two leads of the IC at the top of the schematic.

After the CPLD has been programmed, the result is thus an oscillator whose output (pin 81 on the circuit board) is connected to pin 83 of the CPLD. This input is specially intended to act as a clock input.

Arrays

We assume that you are familiar with doing arithmetic in the binary number system. If you are, you are certainly aware that numbers are usually represented by a group of signals. In Verilog, several signals can be conveniently grouped into a structure called an 'array'.

In the Verilog file for the *Count* block, you will thus see the following in line 40: 'output [7:0] D;'. This specifies an array of eight signals (D[7]...D[0]). This group of signals can be collectively written as 'D'.

To avoid possible confusion, we have to explain line 47. Here a new signal is declared. This signal is not present in the module declaration, which means that it is not externally visible (outside the module). Such a signal is purely for internal use.

The next interesting line is line 51: 'temp=temp+1;'. This shows that we can count by simply using the + sign. Table 2 lists additional arithmetic operators that can be used with arrays in Verilog.

In line 52 you can see a comparison ('==' means to check whether the left-hand term is equal to the right-hand term). All of the relational operators (such as '==') are listed in Table 3. The number 24'd4000000 may appear a bit strange at first glance. This is the notation for writing numbers in Verilog. The first number indicates how many signals are involved (in this case, 24). The 'd' indicates that the constant is stated in decimal notation. Finally,

'4000000' is the actual constant.

In this case we must use 24 signals, since the register *temp* consists of 24 signals. Note that in Verilog, 24 zeros is not the same as 23 zeros! That means that you must make sure that the same number of signals are present on each side of the '=' symbol.

Counter

If you analyse the Verilog code, you will see that the value of register *temp* is incremented on each clock pulse. As soon as the register reaches the value 4,000,000, register D is incremented by the value '1', *temp* becomes '0' and output *SLOW* becomes '1'. If register *temp* has not yet reached the value 4,000,000, *SLOW* receives the value '0'. With a 4.000-MHz clock signal, this means that the value of register D is incremented once per second, with output *SLOW* briefly going to '1'. *SLOW* is thus a 1-Hz clock signal.

BCD counter

The 1-Hz clock signal goes to the clock input of a BCD counter. This is labelled 'BCD_counter' in the schematic diagram.

The Verilog code for the BCD counter has three separate sections, each of which begins with an *always* statement. In addition, we should point out that two registers are declared for internal use: *SEG* and *COUNT*.

The first function (starting at line 52) is a counter that causes the *COUNT* register to count from 0 to 9. When it reaches the value 10, *COUNT* is reloaded with the value 0.

The second function is traversed each time *COUNT* changes. In line 60 you will find a new statement with the name case. An example of this can be found in Listing 3. C programmers will

Listing 3. The case statement, and grouping signals into an array

```
59 always @ (COUNT)
60 begin
61   case (COUNT)
62     4'd0 : SEG=7'b1111110;
63     4'd1 : SEG=7'b0110000;
        .....
64     4'd9 : SEG=7'b1111011;
65     default : SEG=7'b0000001;
66   endcase
67 end
68
69 always @(SEG)
70 {SEGA, SEGB, SEGC, SEGD, SEGE, SEGF, SEGG} = SEG;
```

find this a familiar concept. In this instance, the case statement has one argument (*COUNT*). This means that the following lines:

```
"4'd0 : SEG=7'b1111110;
4'd1 : SEG=7'b0110000;"
```

can be translated as:

```
if (COUNT==4'd0) SEG=7b...
else if (COUNT ==4'd0 SEG=..."
```

and so on.

The line starting with *default* is processed if the current value of *COUNT* does not appear in the list.

The last section of the Verilog code starts at line 75. As you can see, it is evaluated if the value of register *SEG* changes.

An interesting feature of Verilog can be seen in line 76: several signals can be grouped into an array by using the '{' and '}' characters. As *SEG* is an array and the outputs for the seven-segment display have been declared as individual signals, they must be combined into an array.

Another possible solution would be to couple each signal to an element of the array, for example by using:

```
"SEGA = SEG[6];"
```

This method works just as well, but it would make the code quite a bit longer and thus more difficult to read.

Testing

With regard to testing this example, we must mention a shortcoming of the experimenter's board.

When the CPLD is being programmed, all of its outputs assume the non-active state. Immediately after being pro-

grammed, the CPLD is active. As a result, the oscillator does not start properly. This means that after programming the CPLD, you have to briefly reset it. You can do this by fitting a pushbutton switch with a make contact between pins 2 and 20 of connector K6. Alternatively, you can briefly switch the power off and then on again.

Conclusion

You can do a lot more with the Verilog language than what we've been able to describe in this article. Here we have limited ourselves to the most commonly used features of Verilog. Still, these features allow users to design quite complex digital functions. Various sites dealing with a wide variety of designs using Verilog can be found on the Internet. By studying and simulating these designs, you can quickly accumulate experience with this interesting language.

An important aspect that we were unable to discuss in this article (due to lack of space) is simulating designs in Quartus. The Quartus tutorial should help you quite a bit in this regard, and there is also always the Help function. Incidentally, it's a good idea to develop a design in small parts and simulate these small 'subdesigns' one by one in order to determine whether they work the way they should.

We would appreciate hearing from readers who have created their own interesting applications using the experimenter's board. Good luck!

(030385-2)

Web pointers

<http://www.altera.com/support/examples/verilog/verilog.html>

<http://www.asic-world.com/verilog/index.html>

Tips

- A module can consist of several code segments, each of which is preceded by the statement 'always'. Here the limitation is that an output can only be defined in a single code segment. To get around this limitation, a designer can define two signals (such as wires T1 and T1) and control these two signals using separate code segments. The actual output can then be defined as a Boolean function of these two signals.
- Ensure that all flip-flops in the design respond to the same signal edge (rising or falling). This yields a more efficient (faster) design.
- Bear in mind that the compiler evaluates the code. This is fundamentally different from what happens when a processor executes a segment of code. If a design contains several segments using the 'always' keyword, these segments will actually be executed simultaneously

Smooth Ope

for model railway turnouts and semaphores

Ray King

In many model railway layouts, electromagnets instantly snatch turnouts and semaphores from one position to another with an associated 'clunk' noise. Armed with a PIC micro and a small servo, the circuit described in this article provides much slower, smoother, quieter and hence more realistic operation of these mechanical devices.

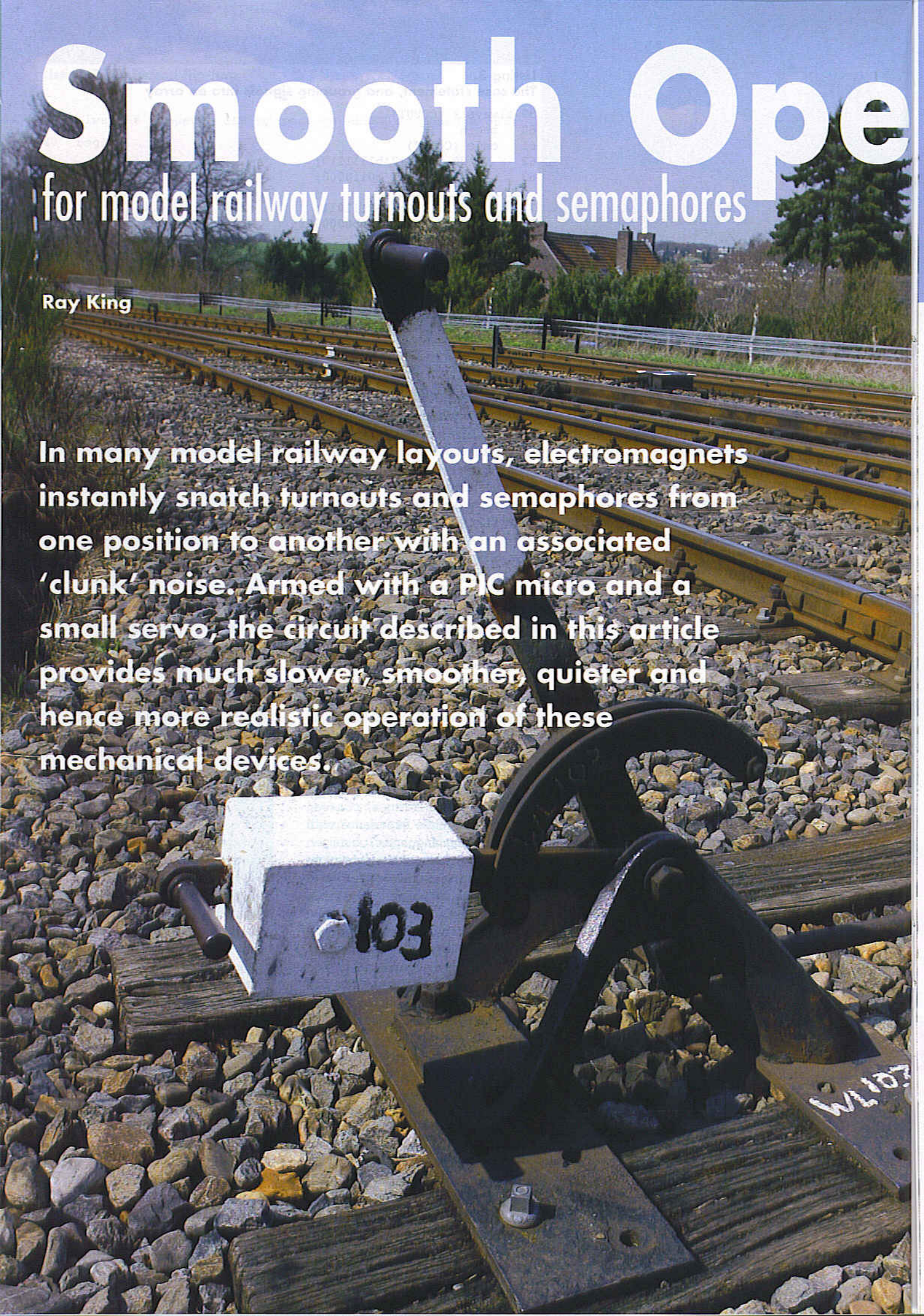

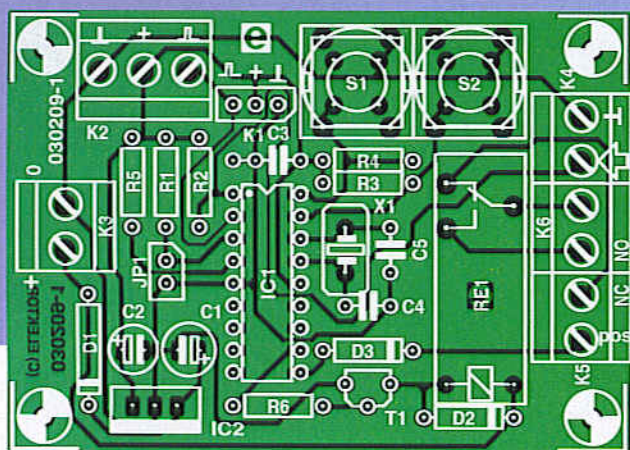

Figure 2. Component overlay of the PCB designed for the turnouts control. The board is available ready-made through The PCBShop.

COMPONENTS LIST

Resistors:

R1-R6 = 10k Ω

Capacitors:

C1 = 100 μ F 25V radial
 C2 = 10 μ F 16 V radial
 C3 = 100nF
 C4,C5 = 22pF

Semiconductors:

D1 = 1N4001
 D2,D3 = 1N4148
 T1 = BC547
 IC1 = PIC16F84-10P, programmed,
 order code 030209-41
 IC2 = 7805

Miscellaneous:

JP1 = 2-way pinheader with jumper
 K1 = 3-way pinheader
 K2 = 3-way PCB terminal block, lead pitch 5mm
 K3-K6 = 2-way PCB terminal block, lead pitch 5mm
 S1,S2 = pushbutton with 1 make contact, e.g., type D6-R
 X1 = 8MHz quartz crystal
 RE1 = relay, PCB-mount, 12V SPDT, e.g., Siemens V23057
 PCB, available through **The PCBShop**
 Disk, Proton PIC Basic Plus source code, order code 030209-11 or **Free Download**

as a feedback signal to the master control system. RB5 effectively controls a relay for use with a 'frog'. Depending on its mechanical structure, the 'frog' employs the normally open (n.o.), normally closed (n.c.) contact, or both. The circuit has an on-board 5-V supply regulator, IC2. The input voltage range should not exceed about 12 VDC.

The PIC has a standard quartz complement in its oscillator circuit consisting of an inexpensive 8-MHz quartz crystal X1 and the two usual small loading capacitors, here C4 and C5.

Printed circuit board

The printed circuit board (PCB) for the turnouts control has been spaciouly laid out. What's more, it contains standard size components only. The component overlay is given in **Figure 2**. Easy to use PCB terminal blocks with 5 mm pin spacing are used for the connectors, except K1 which is a 3-pin pinheader for use with ready-made servo cables. However, in all cases where you are not certain about the servo connections, use terminal block K2 instead. The completed and tested board should be mounted out of sight, which in nearly all cases will mean securing it to the underside of the model railway tabletop. If you do not need 'frog' control, then components R6, T1, D2, K6 and Re1 may be omitted.

Setting up

There are two calibration pushbuttons, S1 and S2. Press them simultaneously and the servo will adopt a central position. The turnout is held in its central

Free Downloads

PIC microcontroller software.
 File number: 030209-11.zip

PCB layout in PDF format.
 File number: 030209-1.zip

www.elektor-electronics.co.uk/dl/dl.htm,
 select month of publication.

Web pointer

How to build a pair of points (turnouts) & pictures of a model 'frog': www.worldrailfans.org/GardenRailway/SLRPointBuilding.shtml

position and attached to the servo's operating arm. Make the control input (RA2) logic High and press S1 and S2 individually to adjust the servo's extreme CCW (counter clockwise) position. Next, make RA2 logic Low and again press S1 and S2 individually until the desired extreme CW (clockwise) position is reached.

If necessary, repeat the adjustments for each level of the control signal, until the servo drives accurately and smoothly from one position to the other. The settings are automatically stored in the PIC's internal EEPROM. Jumper JP1 directs the PIC to use an alternative memory location permitting two settings to be used. Its use is optional.

Software

The source file (.BAS) was written in Proton PIC Basic Plus and should not be too difficult to convert to other PIC compilers. The Proton environment also generates an assembler file which, together with the Basic listing should provide enough clues to adapt the program and assemble it with your favourite assembler for the PIC16F84. The circuit could also be used to operate semaphore signals. By adjusting the parameters for operating speed and/or modifying the program code it should even be possible to mimic the 'bounce' of the semaphore arm as it rises and falls.

(030209-1)

Location photograph courtesy South Limburg Steam Railway Foundation (www.zlsm.nl)

FRUSTRATED!

Looking for ICs TRANSISTORS?
A phone call to us could get a result. We offer an extensive range and with a world-wide database at our fingertips, we are able to source even more. We specialise in devices with the following prefix (to name but a few).



2N 2SA 2SB 2SC 2SD 2P 2SJ 2SK 3N 3SK 4N 6N 17 40 AD
ADC AN AM AY BA BC BD BDT BDV BDW BDX BF
BFR BFS BFT BFX BFY BLY BLX BS BR BRX BRY BS
BSS BSV BSW BSX BT BTA BTB BRW BU BUK BUT BV
BUW BUX BUY BUZ CA CD CX CXA DAC DG DM DS
DTA DTC GL GM HA HCF HD HEF ICL ICM IRF J KA
KIA L LA LB LC LD LF LM M M5M MA MAB MAX MB
MC MDAJ MJE MJF MM MN MPS MPMA MPM MPST
MRF NJM NE OM OP PA PAL PIC PN RC S SAA SAB
SAD SAJ SAS SDA SG SI SL SN SO STA STK STR STRD
STRM STRS SVI T TA TAA TAG TBA TC TCA TDA TDB
TEA TIC TIP TIPL TEA TL TLC TMP TMS TPU U UA
UAA UC UDN ULN UPA UPC UPD VN X XR Z ZN
ZTS + many others

We can also offer equivalents (at customers' risk)

We also stock a full range of other electronic components
Mail, phone, Fax Credit Card orders and callers welcome



Connect

Cricklewood Electronics Ltd

40-42 Cricklewood Broadway London NW2 3ET
Tel: 020 8452 0161 Fax: 020 8208 1441

The Simple Solution! FlexIt

AVR Modular Development System

- Based on the Atmel AVR controller
- Flexible and powerful
- Simple to configure
- Very compact

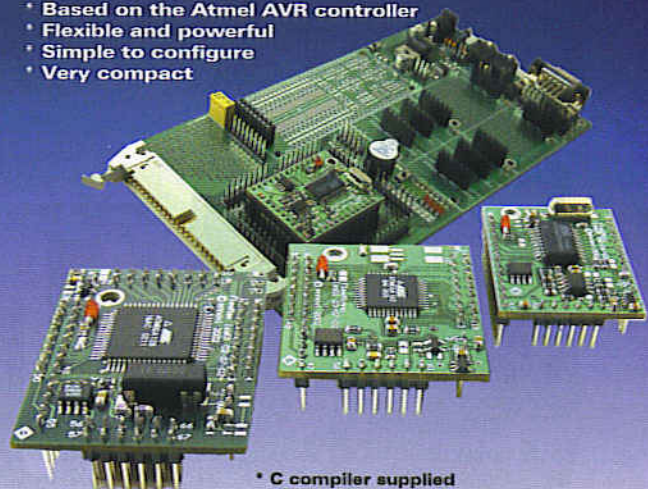

- C compiler supplied
- Compatible with most development tools
- In-system programmable
- Free Atmel debug simulator available
- Peripheral drivers and libraries supplied
- Increasing range of expansion modules
- Full web site support

Check out FlexIt at www.ennovi.co.uk

ennovi Ltd



Dynamic Design
+44 (0)1425 478884
sales@ennovi.co.uk

Precision measurement
Embedded control
Intrinsic safety
Internet embedded systems
USB interface

Easy-PC for Windows

World Beating Value in PCB Design Software

from
£97

High performance Windows based PCB Design Capture,
Simulation and Layout software at prices you'd expect
from your local computer store!



NEW! in Easy-PC 7

- Library Databook
 - Step and repeat plotting
 - Swap Connection Mode
 - Dimensioning
 - Copy to Metafile
- plus much more.....

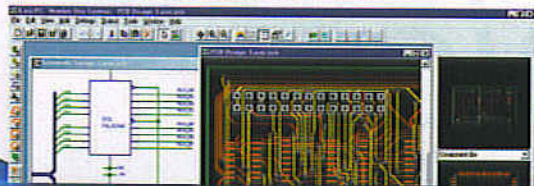

Stop press... by customer demand, now
with Tsien Boardmaker 2 design import...

Number One Systems delivers true 32 bit Windows software applications including features that a few short years ago would only have been available in software tools priced in the thousands!

Test drive Easy-PC and Easy-Spice for yourself and be prepared to be amazed at the super value...

Call for a brochure, price list and demo CD
on +44 (0)1684 773662 or email sales@numberone.com



Number One Systems

Number One Systems
Oak Lane, Bredon
Tewkesbury, Glos GL20 7LR
United Kingdom

or download from
www.numberone.com



**Wouldn't
use yo
as a so**

*Read elektor
electronics.*

leading the way

Can you rather buy our mobile scope?

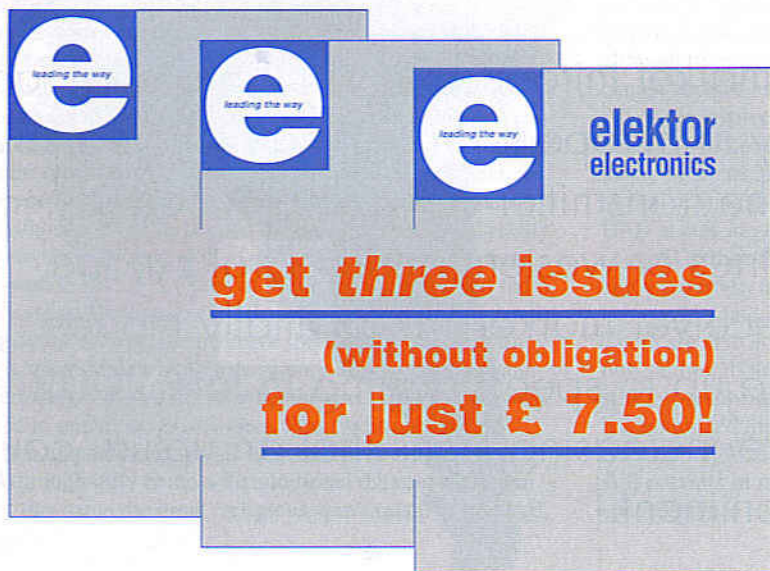

Try out the new
elektor electronics
and get the next 3 issues
(with the July/August
double issue 2004)
delivered at your doorstep.

Your saving:
more than 41%!

Fill out the reply card
with this issue.

The trial subscription
expires automatically.

TEN YEARS AFTER

DAB in Europe

Hans Weber

-  Operational Services
-  Pre-Operational Services

Preparations for the market introduction of DAB digital radio have been underway in Europe for more than ten years. Although setting up the transmitter network proceeded rapidly in most countries of western and central Europe, sales figures in the receiver market were initially modest. In the UK, sales came up to speed starting in late 2002, and recently there are increasing signs that an upturn could also occur on the Continent.



Actually, the strategists and technical specialists in the European radio broadcasting industry all agree that the analogue systems used for FM broadcasting (not to mention medium-wave broadcasting) are technically outdated. Reception quality is not ideal, and the available frequencies are insufficient to meet the demand. They argue that within 15 years, radio broadcasting should be completely converted from analogue to digital. Nevertheless, Digital Audio Broadcasting (DAB) initially remained stuck in the starting blocks. Until recently, Germany (of all countries) provided a splendid example of an unsuccessful strategy.

Please wait...

With wonderful regularity, the 'breakthrough' of DAB was forecast every two years at the Berlin Broadcasting Exhibition. There plans for constructing the transmitter network were presented, public and commercial programme providers declared their willingness to quickly enter into the era of digital radio broadcasting, and several manufacturers presented prototypes and (later on) equipment ready for mass production, although at prices beyond the pale of commercial reality. Nationwide coordination and frequency assignments were discussed in the committees of the federally organised radio broadcasting administration. Broadcasting experts disputed the question of whether listeners should be provided with their accustomed programmes in both digital form and analogue form ('simulcast'), or whether new programmes were needed to attract new customers. Was traditional radio broadcasting sufficient as an application, or would the breakthrough only come with additional data services? On top of this came the great 'religious war': was it to be DAB,

DVB-T, or possibly even DRM?

The decision was announced only last year: the digital successor to VHF (FM) radio could only be DAB. A DVB-T transmitter network providing truly national coverage could not be expected in the near future, since it was not clear who would pay for it. Furthermore, an independent DVB-T multiplex for radio broadcasting alone would not be economically viable, except perhaps in large urban areas, which would mean that radio programmes would only originate as 'companions' to TV programmes and would take second place to them. And in its present form, the third sort of terrestrial digital radio, DRM, is not suitable for servicing regional customers, let alone local customers. The conclusion of a long dispute was thus that DAB, DVB-T and DRM were conceived for three different application areas, and although they can coexist and complement each other, they cannot replace each other.

All of the involved parties agreed on at least one thing: establishing DAB could only succeed with generous state assistance. In the technical area, there was already a substantial stream of state funding. The infrastructure for converting to DAB is now largely in place in Germany. More than 80 percent of German citizens are presently considered to already enjoy coverage, and nearly complete coverage should be achieved by late 2005.

There are also a sufficient number of programmes available now, although the question of which strategy is correct has still not received a unanimous answer. Bavaria in particular has embraced the strategy of providing new programmes that cannot be received via VHF. The simulcast philosophy still prevails in many other German states, primarily for cost reasons.

Figure 1.
International DAB
broadcasting
(source: World DAB Forum)

Figure 2. DAB coverage in the UK.

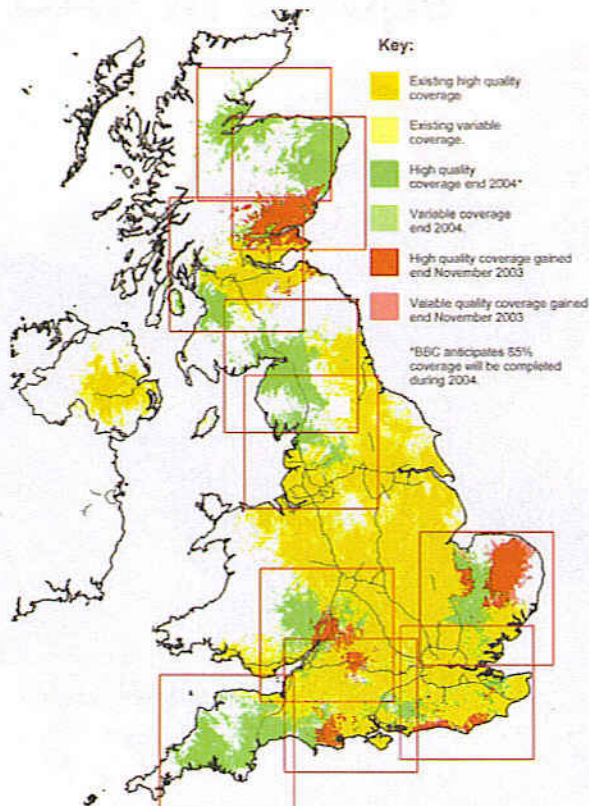

Consumers have apparently not gained very much from all of this: the number of receivers sold up to now is estimated to be around 100,000. That is presumably because there is not yet sufficient awareness of the product. Most Germans regard DAB as a brand of beer, and the trademark currently being used, 'Digital Radio', does not provide adequate differentiation from other types of digital radio broadcasting. As the marketing organisations to be found in almost all of the German states explain, 'First we invested a lot of money in the technology, and now we have to invest even more in promotion'. Success will still take a while.

The 99-quid radio

The situation in Great Britain is quite different. Here the market started to move in late 2002. It was recognised that the only way to achieve widespread market penetration of DAB receivers was via the price. The 'magic boundary' was considered to be a receiver under the 100-pound level. The initiative for producing a '99-quid kitchen radio' did not come from the manufacturers or a similar group, but instead from the programme providers. The BBC and commercial broadcasters, in particular Digital One, provides funding for developing an IC named 'Chorus'. The manufacturing cost of this IC was so low that the receiver price could be brought below the magic boundary, although at first this was only possible with additional subsidies. Shortly before Christmas 2002, the Pure Digital Evoke-1 went on sale in selected shops following an extensive advertising campaign, and it was sold out after only a few hours. This 'initial spark' encouraged other manufacturers to join the competition with attractively priced offerings. Not only did this drive down prices (presently, the cheapest receiver costs around 70 pounds, equivalent to 105 euros), it also increased awareness and attracted other customers who were willing to pay somewhat higher prices. The number of DAB receivers sold in the UK has risen from approximately 50,000 in mid-2002 to the present figure of more than half a million — and that with a degree of coverage originally comparable to that in Germany, and now even somewhat lower.

Of course, the initial situation in Great Britain was also different. Medium-wave broadcasting is much more common here than elsewhere, so the difference in reception quality is more evident than with FM broadcasting. In addition, greater emphasis was placed on 'new' programmes (which cannot be received using analogue receivers), and they were promoted in the media.

Another advantage relative to Germany is that in the UK, DAB is available in only one frequency band (Band III, 174–240 MHz). In Germany, DAB is also transmitted in the L band (1452–1492 MHz), which unfortunately increases costs and reduces transmitter range.

West Europe: a varied situation

Nearly complete coverage has been established in Belgium, which has the highest level of coverage (95 %) in all of Europe.

In France, the focus was on large metropolitan areas from the very beginning. DAB programming is available in Paris, Lyon, Marseille, Toulouse and Nantes, and in total 25 to 30 percent of the population can be reached. In the Nether-



Figure 3. The Restek EDAB high-end DAB tuner (www.restek.de).



Figure 4. Compact DAB receivers for the 'German' L band are available at less than 200 euros (www.thiecom.de). The receiver on the right can also receive VHF broadcasts.

DAB inside

If you look for components for DAB receivers, you will quickly find two British manufacturers: FrontierSilicon (www.frontier-silicon.com) and RadioScape (www.radioscape.com). FrontierSilicon's product line is based on the Chorus FS1010. This IC is a highly integrated multimedia processor with ADC input, a DSP processor core, DAB coprocessors, on-chip RAM and cache memory, and a wealth of on-board peripheral. The DAC is not integrated, so users are free to spend as much as they wish on this component (or as little as they wish, if cost is an objective). For equipment manufacturers, FrontierSilicon also provides convenience products in the form of complete modules that include the RF front end (tuner) and several peripheral components. To produce a complete receiver, the manufacturer only has to add his own user interface (control processor, display and buttons), audio portion (DAC, buffer, sockets or Toslink, etc.), and an enclosure.

RadioScape goes a step further with its tiny RS200 Module Board, which uses the Texas Instruments DRE200 DAB IC and incorporates all of the functions of a DAB/FM digital radio. As you can see from the illustration, a complete DAB/FM tuner can be made by simply adding a few pushbuttons, a rotary encoder, a standard LCD module (2 × 20 characters) and a power supply. With its compact dimensions, the RadioScape module can also be used to build pocket radios.

It's certainly not much of a secret that most DAB receivers are fitted with such modules. As an example, the photos show what's inside the DAB tuner from Restek's Audio Mini Module series (www.restek.de).

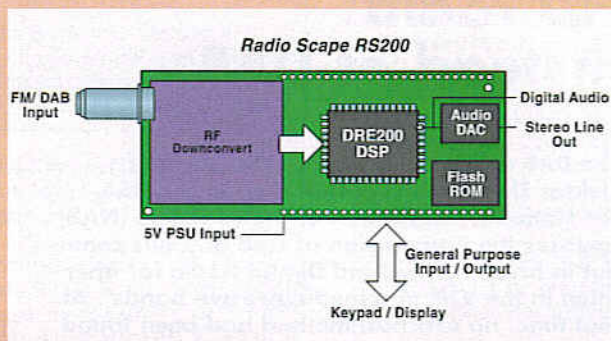

Almost plug-and-play: the RadioScape RS200 DAB/FM tuner module (www.radioscape.com).

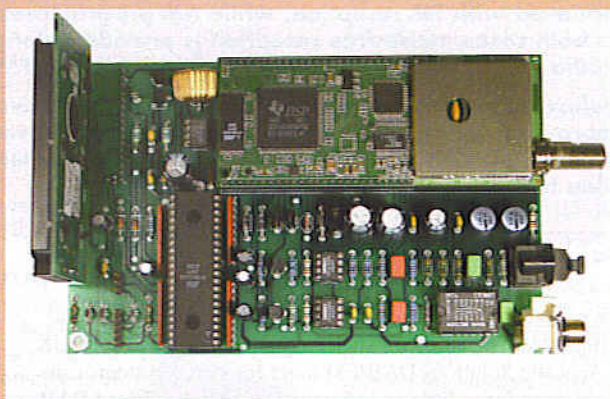

The module used in the DAB tuner in Restek's Audio Mini Module series.

lands, regular DAB operation was only started on 27 February 2004 after a five-year test phase, which surprisingly made the Netherlands the last of the pre-expansion EC countries to introduce regular DAB service. There as well, availability is concentrated in regions with high population density, and according to official statements, approximately 40 percent of the population is currently covered.

All of these countries have in common that the number of receivers sold lags behind the technical investments in the transmitting network. This may in part be due to the fact that in the beginning, relatively small markets are not especially attractive for large manufacturers.

The receiver market

The end-user market is divided into four major segments. The first of these is car radios, which in Germany was initially regarded as the most important market segment. Prices in this segment are relatively stable. The market leader, Blaupunkt, offers its Woodstock 53 (!) model for 579 euros. The Grundig

Allix is somewhat less expensive at 399 euros. Prices do not vary much from one country to the next. Only the UK is again slightly ahead of the curve, with a model (Goodmans) available for less than 200 pounds.

The situation with mobile and portable receivers is different. In the UK, the market is dominated by small, inexpensive receivers that can only receive Band III. Portable receivers are available starting at around 70 pounds. By contrast, prices in Germany maintained a lower limit of approximately 200 euros until recently. This situation changed at the CeBIT exhibition, where TechniSat presented a pair of lower-priced receivers: the DAB-Man for 169.99 euros and, for home use, the Digit-Radio DAB for 159.99 euros. Visitors to the CeBIT could also admire the first combined DAB/DRM receiver, the Starwaves Prelude. This receiver, which is made by a small manufacturer in Hanover, will not become commercially available until late this year. The price is said to be 'in the high three-figure' euro range.

In Germany, DAB tuners for hi-fi systems are still the domain of the high-end manufacturers, such as Restek

Things are different in the USA:

HD radio instead of DAB

The DAB article in the April 1998 issue of *Elektor Electronics* reported that 'in the USA, the National Association of Broadcasters (NAB) opposes the introduction of DAB and has come out in favour of In-Band Digital Radio for operation in the VHF and medium-wave bands'. At that time, no practical method had been found to implement such a solution. The situation has changed since then: under the name 'HD Radio', iBiquity Digital Corporation (www.ibiquity.com) developed a technique that allows digital programmes to be broadcast on existing AM and FM frequencies using existing transmitters. This can be done in combination with conventional AM and FM programmes, which can continue to be broadcast on the same frequencies. All that is necessary to enjoy the improved sound quality and data services of HD Radio is to buy a new receiver with HD Radio capability. CD quality can be achieved with FM reception, while AM programmes have the same quality as current FM broadcasts. In both cases, noise-free reception is provided along with supplemental data functions. Most HD Radio receivers can also receive normal AM and FM broadcasts.

Before even a single receiver was commercially available, iBiquity managed to grant licenses to more than 280 radio stations in 37 US states. Component manufacturers, such as Alps (front-end tuners, A/D and D/A converters, and signal processors) and Philips (SAF3350 HD Radio Processor) plan to start mass production this year.

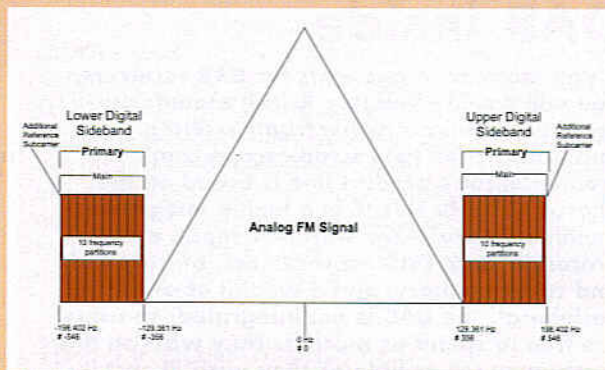

The hybrid HD Radio signal consists of a frequency-modulated main carrier (for FM programmes) and digitally modulated sidebands for HD Radio.

(www.restek.de). Particularly demanding listeners can spend as much as 2700 euros for such a DAB tuner, while in the UK an Acoustic Solutions DAB/FM tuner for stereo systems can be obtained for as little as 115 pounds. Computer-based DAB radios, by contrast, are scarce. The only model available in all countries is the TerraTec DR Box 1 (300 euros or about 210 pounds).

Summaries of available equipment and prices can easily be found on the Internet, such as at www.digitalradio.de for Germany and www.digitalradionow.com for the UK.

What about the future?

In Germany, DAB has been pronounced dead once already. Presently, the situation can be regarded as being more positive. It appears that prices could again drop in the near future: the Anglo-Israeli company Sonarics is offering their CSM DAB module for US\$ 25, and the Analog Devices Blackfin DSP, which allows DAB functionality to be implemented in software, is available at 5 dollars in large quantities. At last, the large manufacturers (in particular Sony) are indicating their willingness to enter the market. In parallel with this, promotional efforts are being increased and coordinated under the direction of Initiative Marketing Digital Radio (IMDR). In any case, in Germany hopes are now being pinned on a 'soft transition' instead of a 'breakthrough'. The demand that VHF radio broadcasting simply be stopped by 2015 (or even earlier) has now been dropped.

(040101-1)

References:

'Digital Audio Broadcasting (DAB)', Part 1 / Part 2, *Elektor Electronics*, March / April 1998.

Web pointers:

www.worlddab.org
www.digitalradio.de
www.radionumerique.be
www.pure-digital.com
www.drdb.org
www.digitalradionow.com
www.restek.de
www.sonarics.com
www.thiecom.de
www.technisat.de
www.radioscape.com
www.frontier-silicon.com



Quasar Electronics Limited
PO Box 6935, Bishops Stortford,
CM23 4WP
Tel: 0870 246 1826
Fax: 0870 460 1045
E-mail: sales@quasarelectronics.com

Add £3.00 P&P to all UK orders or 1st Class Recorded - £5,
Next Day (Insured £250) - £8, Europe - £6, Rest of World - £10 (order
online for reduced price UK Postage).
We accept all major credit/debit cards. Make cheques/PO's payable
to Quasar Electronics. Prices include 17.5% VAT.
Call now for our FREE CATALOGUE with details of over 300 kits,
projects, modules and publications.
MAIL ORDER ONLY.



QUASAR **0871** CREDIT CARD **717 7168**
electronics SALES

Helping you make the right connections!

Motor Drivers/Controllers

Here are just a few of our controller and driver modules for AC, DC, unipolar/bipolar stepper motors and servo motors. See website for full details.

DC Motor Speed Controller (5A/100V)

Control the speed of almost any common DC motor rated up to 100V/5A. Pulse width modulation output for maximum motor torque at all speeds. Supply: 5-15VDC. Box supplied. Dimensions (mm): 60Wx100Lx60H. Kit Order Code: 3067KT - £12.95
Assembled Order Code: AS3067 - £19.95

NEW! PC / Standalone Unipolar Stepper Motor Driver

Drives any 5, 6 or 8-lead unipolar stepper motor rated up to 6 Amps max. Provides speed and direction control. Operates in stand-alone or PC-controlled mode. Up to six 3179 driver boards can be connected to a single parallel port. Supply: 9V DC. PCB: 80x50mm. Kit Order Code: 3179KT - £9.95
Assembled Order Code: AS3179 - £16.95



PC Controlled Dual Stepper Motor Driver

Independently control two unipolar stepper motors (each rated up to 3 Amps max.) using PC parallel port and software interface provided. Four digital inputs available for monitoring external switches and other inputs. Software provides three run modes and will half-step, single-step or manual-step motors. Complete unit neatly housed in an extended D-shell case. All components, case, documentation and software are supplied (stepper motors are NOT provided). Dimensions (mm): 55Wx70Lx15H. Kit Order Code: 3113KT - £15.95
Assembled Order Code: AS3113 - £24.95



NEW! Bi-Polar Stepper Motor Driver

Drive any bi-polar stepper motor using externally supplied 5V levels for stepping and direction control. These usually come from software running on a computer. Supply: 8-30V DC. PCB: 75x85mm. Kit Order Code: 3158KT - £12.95
Assembled Order Code: AS3158 - £26.95



Most items are available in kit form (KT suffix) or assembled and ready for use (AS prefix).

Controllers & Loggers

Here are just a few of the controller and data acquisition and control units we have. See website for full details. Suitable PSU for all units: Order Code PSU345 £9.95

Rolling Code 4-Channel UHF Remote

State-of-the-Art. High security. 4 channels. Momentary or latching relay output. Range up to 40m. Up to 15 Tx's can be learnt by one Rx (kit includes one Tx but more available separately). 4 indicator LED's. Rx: PCB 77x85mm, 12VDC/6mA (standby). Two and Ten channel versions also available. Kit Order Code: 3180KT - £41.95
Assembled Order Code: AS3180 - £49.95



Computer Temperature Data Logger

4-channel temperature logger for serial port. °C or °F. Continuously logs up to 4 separate sensors located 200m+ from board. Wide range of free software applications for storing/using data. PCB just 38x38mm. Powered by PC. Includes one DS1820 sensor and four header cables. Kit Order Code: 3145KT - £19.95
Assembled Order Code: AS3145 - £26.95
Additional DS1820 Sensors - £3.95 each



NEW! DTMF Telephone Relay Switcher

Call your phone number using a DTMF phone from anywhere in the world and remotely turn on/off any of the 4 relays as desired. User settable Security Password, Anti-Tamper, Rings to Answer, Auto Hang-up and Lockout. Includes plastic case. 130x110x30mm. Power: 12VDC. Kit Order Code: 3140KT - £39.95
Assembled Order Code: AS3140 - £49.95



Serial Isolated I/O Module

PC controlled 8-Relay Board. 115/250V relay outputs and 4 isolated digital inputs. Useful in a variety of control and sensing applications. Uses PC serial port for programming (using our new Windows interface or batch files). Once programmed unit can operate without PC. Includes plastic case 130x100x30mm. Power Supply: 12VDC/500mA. Kit Order Code: 3108KT - £54.95
Assembled Order Code: AS3108 - £64.95

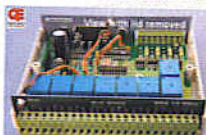

Infrared RC Relay Board

Individually control 12 on-board relays with included infrared remote control unit. Toggle or momentary. 15m+ range. 112x122mm. Supply: 12VDC/0.5A
Kit Order Code: 3142KT - £41.95
Assembled Order Code: AS3142 - £51.95



PIC & ATMEL Programmers

We have a wide range of low cost PIC and ATMEL Programmers. Complete range and documentation available from our web site.

Programmer Accessories:

40-pin Wide ZIF socket (ZIF40W) £15.00
18V DC Power supply (PSU010) £19.95
Leads: Parallel (LEAD108) £4.95 / Serial (LEAD76) £4.95 / USB (LEADUAA) £2.95

NEW! USB 'All-Flash' PIC Programmer

USB PIC programmer for all 'Flash' devices. No external power supply making it truly portable. Supplied with box and Windows Software. ZIF Socket and USB Plug A-A lead not incl. Kit Order Code: 3128KT - £39.95
Assembled Order Code: AS3128 - £49.95



Enhanced "PICALL" ISP PIC Programmer

Will program virtually ALL 8 to 40 pin PICs plus a range of ATMEL AVR, SCENIX SX and EEPROM 24C devices. Also supports In-System Programming (ISP) for PIC and ATMEL AVRs. Free software. Blank chip auto detect for super fast bulk programming. Requires a 40-pin wide ZIF socket (not included). Available in assembled format only. Assembled Order Code: AS3144 - £59.95



ATMEL 89xxx Programmer

Uses serial port and any standard terminal comms program. 4 LED's display the status. ZIF sockets not included. Supply: 16-18VDC. Kit Order Code: 3123KT - £29.95
Assembled Order Code: AS3123 - £34.95



NEW! USB & Serial Port PIC Programmer

USB/Serial connection. Header cable for ICSP. Free Windows software. See website for PICs supported. ZIF Socket/USB Plug A-A lead extra. Supply: 18VDC. Kit Order Code: 3149KT - £39.95
Assembled Order Code: AS3149 - £54.95



www.quasarelectronics.com

Secure Online Ordering Facilities • Full Product Listing, Descriptions & Photos • Kit Documentation & Software Downloads

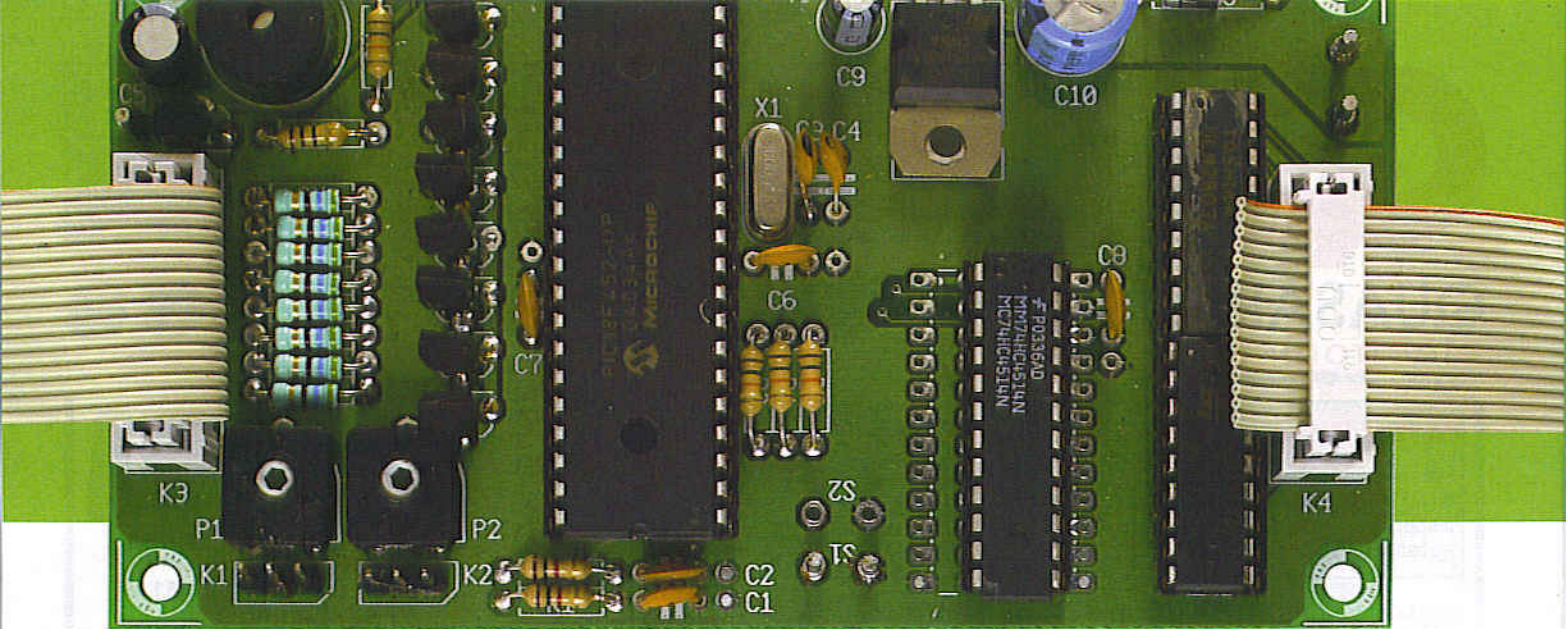

Pocket Pong

a primeval game cast in modern hardware

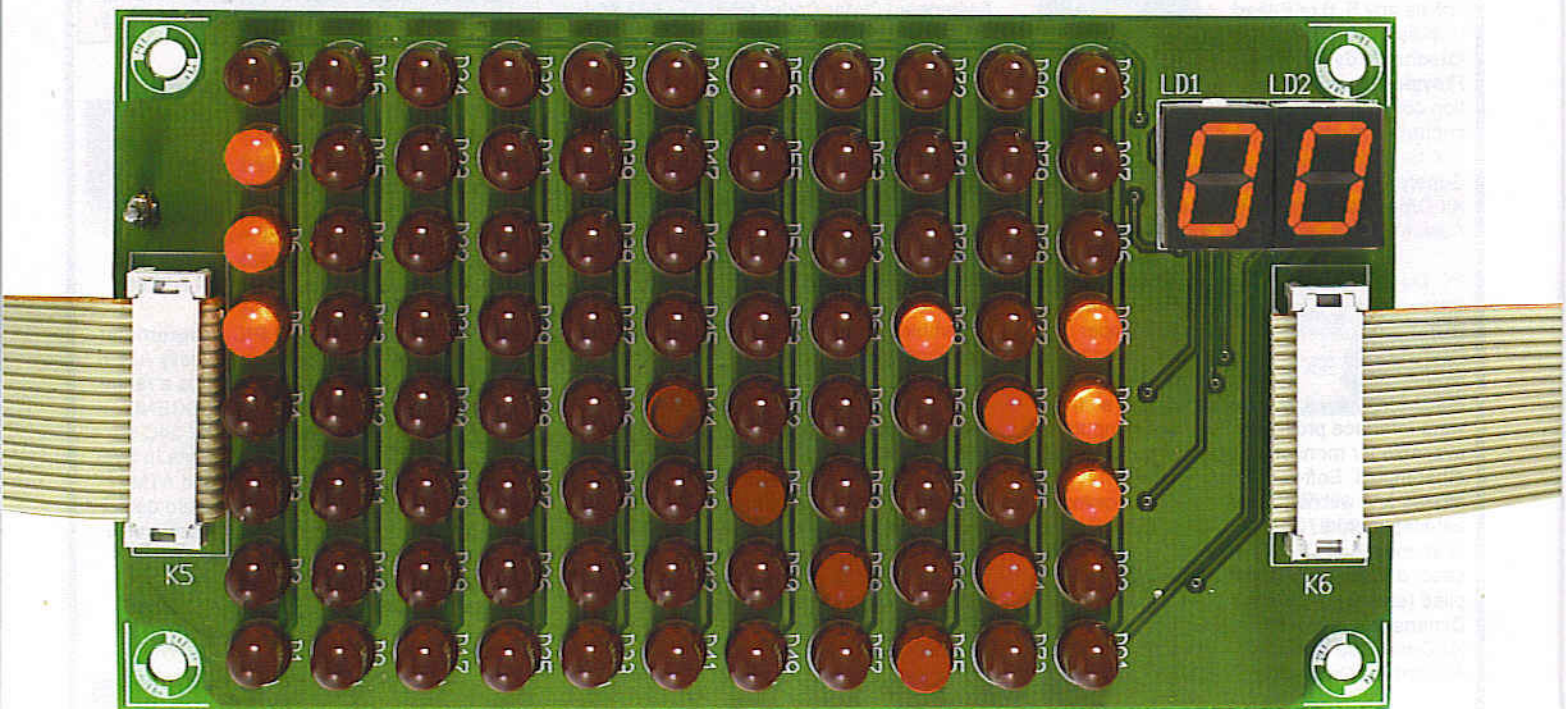

Andy Morell

Provided they manage to recognise them in the first place, youngsters will label classics like Pacman and Pong as video games although historically they are 'video games', the concept behind them dating back to the 1950's. In this article you'll find a modern (computer) version of such a prehistoric game that — as far as we are concerned — has not lost any of its compulsive character.

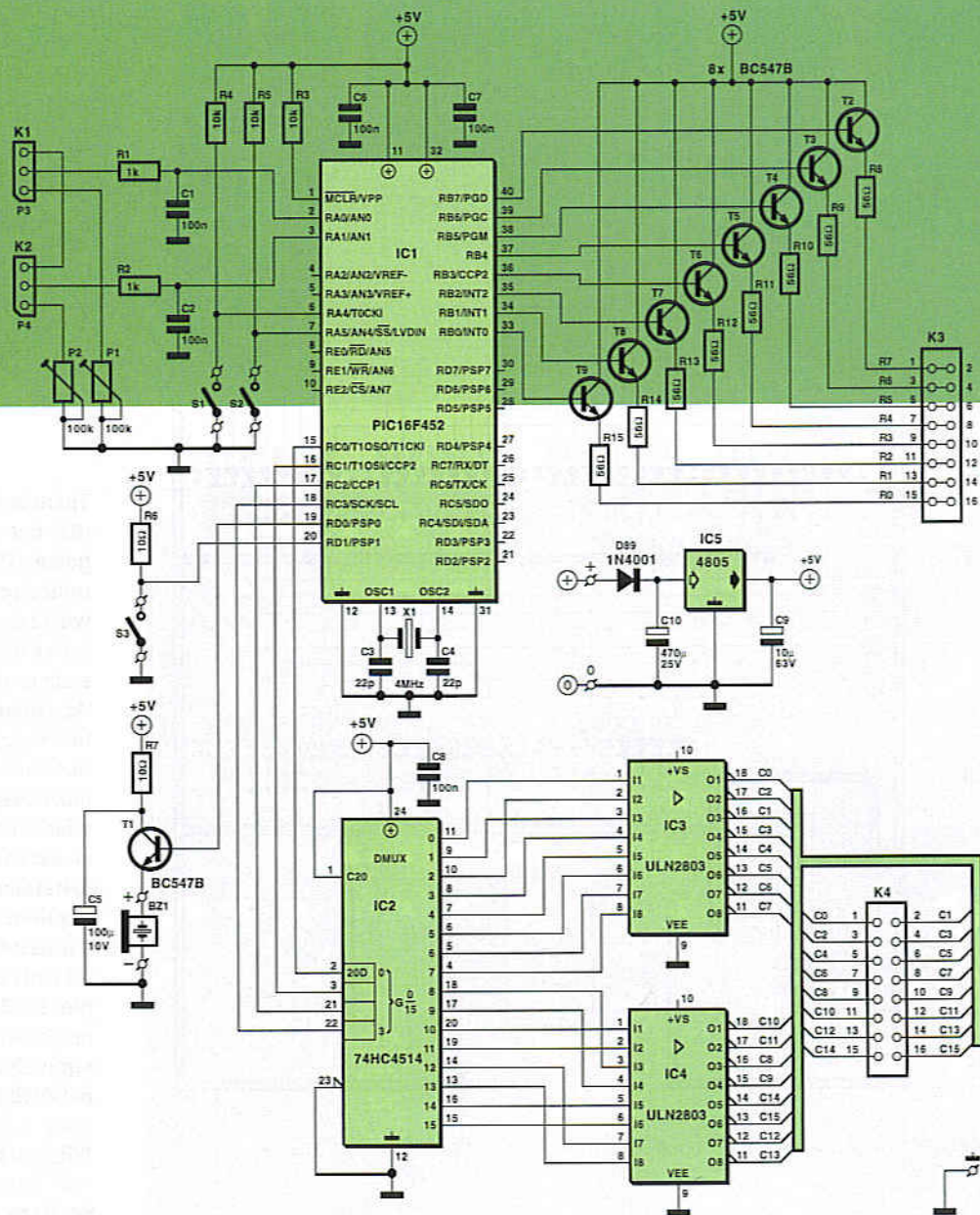

It is easily forgotten that the first electronic games were played on a TV set. In fact, technology at the time nearly did not make it to TV altogether. In 1951, TV technician Ralph Baer thought it would be nice to use the telly as a screen for an electronic game. His boss however did not see the promise and the idea was quickly abandoned. Years later, however, it started to surface again and in 1966 Baer started to build one of his early prototypes. The video game was born. The game covered by this article is Atari's 'Pong' which is actually a derivate of one of Baer's original concepts. The first versions for use at home were designed around 1974. As opposed to other manufacturers, Atari found the pot of gold: an ASIC (application specific integrated circuit) was designed for Pong. The chip allowed

the production costs to be kept low while the game functionality (including a digital on-screen scoreboard and sound effects) was excellent compared to competitive products. The home version of Pong was launched in 1976. Today, 28 years later, we have another go at casting Pong in electronics. This time, we will not be using a TV set for the 'screen' but a LED matrix.

The circuit

Just like Atari did many years ago, we will be designing a chip tailored to the game only. Fortunately, that no longer means you have to design a completely new circuit and burn it into a chip. Today we simply use a microcontroller running software that tells it exactly what to do. We chose the PIC18F452, a 40-pin MCU containing,

among others, 32 kBytes of program memory and a 10-bit A-D converter. As you can see from **Figure 1**, the PIC is not the only IC in the circuit. IC2, a 4-to-16 line decoder, together with IC3 and IC4 arranges the display control. The display actually consists of two parts: the 7-segment displays LD1 and LD2 showing the 'score' and a LED matrix (D1-D88) that mimics the playing field. Virtual rackets or bats move at the left and right side of the court, allowing the ball to be bounced back and forth.

Buzzer Bz1 provides the sound effects. You are looking at a dc (or 'active') piezo buzzer that's driven by transistor T1. C5 and R7 afford sufficient decoupling of the supply voltage.

The power supply around IC5 is dead standard. Diode D89 affords a degree of protection against an accidentally

COMPONENTS LIST

Resistors:

R1,R2 = 1kΩ
 R3-R6 = 10kΩ
 R7 = 10Ω
 R8-R15 = 56Ω
 P1,P2 = 100kΩ preset

Capacitors:

C1,C2 = 100nF
 C3,C4 = 22pF
 C5 = 100μF 10V radial

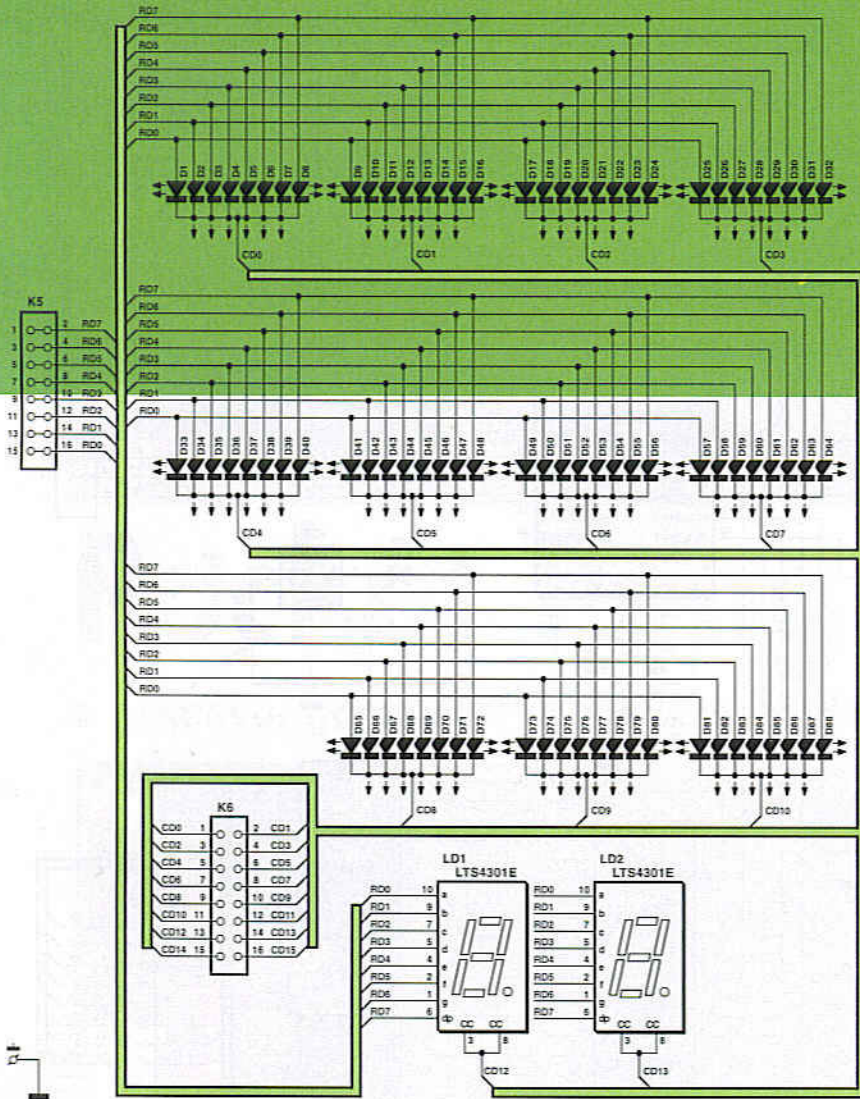

Figure 1. In this game, the 'screen' is formed by a huge number of LEDs.

reverse polarized mains adapter (with 9-12 VDC output). With the PIC drawing just a few milliamps, it is fair to say that the current consumption of our electronic game goes on account on the LEDs. However, thanks to the multiplexed drive scheme used here, the average current consumption remains limited to a modest 35 mA or so.

Display

Both the LEDs in the 7-segment displays and the LEDs in the matrix have their cathodes connected via ULN2803 driver ICs (IC3 and IC4). The anodes are connect to the MCU port lines via transistors T2-T9. It would appear that the transistors are not strictly necessary as the PIC port lines are specified at 25 mA each. This may well be sufficient for high-efficiency LEDs, but it isn't with regular LEDs which at such a low current light dimly, reducing the

'playability' of the game.

Using the indicated component values (i.e. with transistors and R8-R15 = 56 ohm) a LED current of about 27 mA is obtained. By the way, the value of R8-R15 may be changed without problems using Ohm's law. Assume a supply voltage of 5 V, then subtract the following: collector-emitter drop (0.7 V); LED 'on' voltage (approx. 1.8 V for red LEDs); voltage drop across Darlington drivers in the ULN2803 (approx. 1 V). That leaves about 1.5 V across the resistor. If the desired current is 10 mA, $V = I \times R$ tells you that $1.5 = 0.01 \times R$, or $1.5 / 0.01 = 150$ ohms.

Operation

The game is played using two potentiometers and two switches. S1 serves to serve a ball. S3 is the speed selector. When it is closed, the ball moves faster making the game more difficult to play.

There is a connection for a third switch (S2) but this is not used in the Pong game. P3 and P4 may be ordinary rotary potentiometers but slide pots will of course give a more realistic control of the bats on the field. A real joystick is of course the ultimate.

'Analogue' PC joysticks in general contain two potentiometers, one for each direction (horizontal and vertical). In most cases 470-kohm pots are used of which the 0-120 kohm resistance range is actually used. For our circuit, a resistance range of 0-4.7 kohm is required, so if a joystick is connected, a resistor has to be connected in parallel with the input (between +5 V and pin 2 / 3 of the PIC) to make sure a much lower resistance is obtained. The equivalent resistance of the parallel network is calculated from

$$1/R_{eq} = 1/R1 + 1/R2$$

So, if we want 4.7 kohms and the joystick R1 = 120 kohms then

$$1/R2 = 1/120k - 1/4.7k$$

$$R2 = 4.89 k$$

In practice no problems will occur if you use a resistor of 4.7 kohms.

Pins 1 and 3 on the 15-way joystick connector (a sub-D type) are for the horizontal direction and pins 1 and 6 for the vertical direction.

Finally, R1/C1 and R2/C2 suppress noise generated by the potentiometers as they are operated.

Construction

The printed circuit board (Figure 2) consists of two parts interconnected with a piece of flatcable. Building the LED matrix is sure to take some time. Although the job itself is straightforward, we should emphasize the importance of checking the LED polarity because it is hard to think of anything

C6,C7,C8 = 100nF
 C9 = 10µF 63V radial
 C10 = 470µF 25V radial

Semiconductors:

D1-D88 = LED, red, high-efficiency, 5mm, e.g., HP HLMP-D101 (Farnell # 323-044)
 D89 = 1N4001
 LD1,LD2 = LTS4301E LiteOn
 T1-T9 = BC547B

IC1 = PIC18F452-I/P
 IC2 = 74HC4514 (74HCT4514 or 4514)
 IC3,IC4 = ULN2803
 IC5 = 4805

Miscellaneous:

K1 = P3 = 4kΩ7 (5kΩ) linear potentiometer, and a 3-way SIL pinheader
 K2 = P4 = 4k7 linear potentiometer, mono, + 3-way SIL pinheader

K3,K4 = 16-way boxheader
 K5,K6 = 16-way flatcable connector for PCB mounting
 S1 = pushbutton, 1 make contact
 S2 = not fitted
 S3 = switch, on/off
 X1 = 4MHz quartz crystal
 BZ1 = 5V (DC) piezo buzzer

more annoying than 88 LEDs fitted the wrong way around. Usually, the cathode is the largest surface inside the LED as well as the shorter pin. Usually... not always, so make sure of the polarity and in case of doubt use a conductance tester.

The orientation of the 7-segment displays may appear to be wrong but if you follow the indications on the component overlay shown in Figure 2 the circuit will work as expected.

The polarity of the electrolytic capacitors and transistors in the circuit also deserve your attention. Also, run a double check on the orientation of the PIC micro before inserting it into its socket — after all, the PIC is the most expensive component.

The circuit board is best mounted into a case that will also accommodate the switches, mains adapter socket, pots and LEDs. A red bezel on top of the matrix clearance and the score displays will provide the finishing touch to the game.

If necessary the game may be powered by four AA batteries. In that case the current through the LEDs has to be reduced, however, by increasing the value of R8-R15. This is necessary to save battery power.

Software

That leaves us with the software burned into the PIC micro, here, a PIC18F452. Since we are looking at a game that should not cost too much, we looked for an ultra-simple programmer that allows anyone to program the chip using his/her PC. The article 'Free PICProg' elsewhere in this issue comes up with the goods. As usual, the PIC software for his project may be obtained free of charge from our website as file number 030320-11 (see Free Downloads, month of publication) The PIC assembly code file is well commented.

(030320-1)

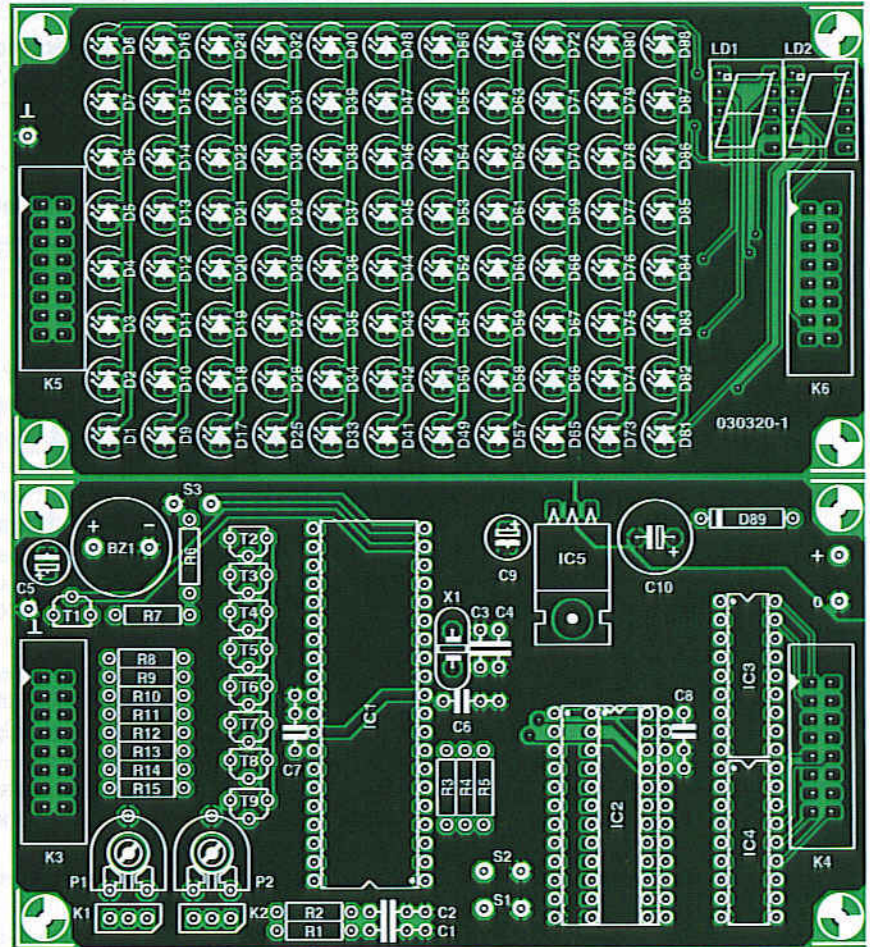
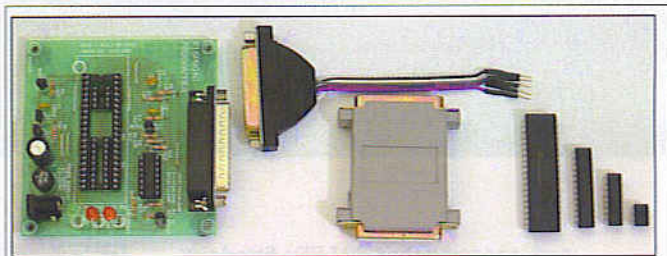
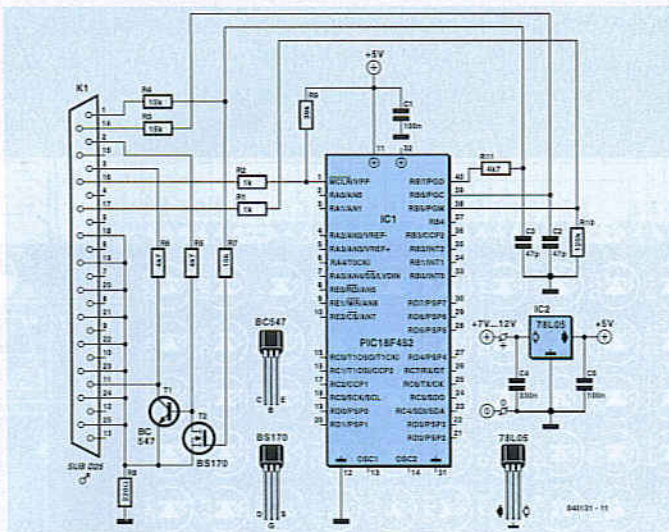

Figure 2. The PCB consists of two parts to be connected with flatcable.



FreePicProg PIC Programmer Version 1.0 (17 January 2004)
 Copyright (c) 2004 Steven Simon

[Click here to download FreePicProg](#)
[Click here to download the FreePicProg source code](#)
[Click here view the C++ source code](#)

Introduction

FreePicProg is a Windows command line application designed to program flash memory based PIC microcontrollers. The FreePicProg software currently supports two PIC programmers: The 'P16PRO40' and my own low voltage in circuit programmer called 'SimplePicProg'.

FreePICProg

cheap 'n easy PIC programming

David Daamen

The PocketPong game found elsewhere in this issue was designed around a PIC18F452 for which, we have to admit, no suitable programmer was ever published in this magazine. Sure, investing in a commercially produced programmer is an option, but making one yourself is cheaper and much more fun, too!

We reckon that's what Steven Simon must have thought when he needed a programmer for one of the newer PIC micros. On his website, Steven describes the software he produced for the purpose — both the executable and the source code files may be downloaded free of charge. The program can work with various hardware variants which are also described on the site. The circuit shown in **Figure 1** is a related item, albeit a very rudimentary one. No LEDs or other

frills — just connect & program!

Construction and operation

The circuit consists mainly of passive parts, the majority of them serving to shape and tidy up various switching signals. Of the active parts, the transistors ensure that the edge steepness of the signal found at the BUSY line (pin 11) is improved. That leaves us with voltage regulator IC1, which we take it is so familiar as to defy further description. The circuit should be easy to build on a small piece of Veroboard. For K1 it is wise to use an angled connector and solder it directly on to the board. The programmer may be plugged directly into the printer port on the PC. The power supply is uncritical and may be realised using a simple mains adaptor with an output voltage of 7-12 VDC.

Software

The little program called 'fpp.exe' allows a HEX file to be burned into the PIC micro. The software is compatible with all versions of Windows. However, because the printer port is accessed, Windows NT, 2000 and XP do require an extra driver to be installed — in this case, 'DLPortIO' from Scientific Software Tools. Incidentally, only LPT1 (0x378h) is supported.

The hardware may be tested by typing this command line:

```
fpp lvp -t
```

where the 'lvp' option specifies the programmer type. You may also choose 'lvp_fast' which speeds up the programming sequence. It may not work in all cases, though, so first give it a try.

Once the hardware has been recognised, the PIC may be installed with the programmer supply switched off. The actual programming operation is launched with

```
fpp lvp <PIC type> -p <HEX file>
```

There are also options for reading a PIC device ID, blank checking, erasing, etc. Type

'fpp' only for an overview of all available parameters.

PICs supported

FPP V1.00 supports the following PIC types:

- 12F629
- 16F876, 16F877, 16F628 (-A suffix versions are not supported!)
- 18F252, 18F452

Although the 12F675 is in principle also supported by the software, the hardware shown here is unsuitable for this particular PIC device. For more information, have a look at the web pages covering FPP

(040131-1)

FPP website:

www.geocities.com/SiliconValley/Hills/1924/freepicprog.html

FPP download from Elektor Electronics:

file # 040131-11,
www.elektor-electronics.co.uk/dl/dl.htm,
 select month of publication.

DLPortIO

www.driverlinx.com/Download/DLPortIO.htm

Analog University

attend National Semiconductor lectures

David Daamen

Sure, the Internet contains thousands of electronic circuits covering equally vast numbers of applications. That's all very well, but King Shallow & Sgt Superficial often rule and it may take a lot of searching if you really want to know all the ins and outs of a certain design aspect. Of course, enough theory may be found in datasheets and application notes published but various renowned manufacturers, but somehow the method does not appear very efficient.

In this month's instalment of *Review Copy* we'd like to draw your attention to National Semiconductor's 'Analog University', a virtual academy that's existed for about a year now and has grown into a sizeable collection of mini courses covering

a wide range of subjects. The curriculum [1] is divided into the following categories:

- *Power Management*, about linear and switch-mode power supplies and converters;
- *LVDS*, about low voltage differential signalling and bus configurations, as well as transmission lines for these technologies;
- *Data Conversion*, about analogue-to-digital converters;
- *Audio*, about thermal properties and cost cutting;
- *Displays*, about the principles behind the design of TFT and CRT screens;
- *Wireless*, basics of RF technology and information on various PLL techniques;
- *Thermal Management*, about thermal control systems, analogue and digital temperature sensors;
- *Amplifiers*, about (high-speed) opamps, low-power and low-voltage amplifiers;

The courseware comprises, among others, articles, application notes and pointers to relevant contributions in the Knowledge Base. Moreover quite a few subjects are supported by Online Seminars. Using a Java presentation — complete with sheets and sound — your lecturer will explain the subject matter in great detail. Eventually, the knowledge acquired in this way may be verified with the aid of a short research assignment or a quiz.

The lectures are also accessible via a separate overview [2]. National's website offers a lot more, including a massive Knowledge Base [3] with a search engine. There's also a section called Design Tools [4] comprising WEBENCH, an on-line design, simulation and construction assistant!

Finally, we should not forget to mention "The Bob Pease Show" aptly called "Reality TV for Analog Designers" by National Semiconductor themselves.

(045043-1)

Web references

- [1] analoguni.national.com
- [2] www.national.com/onlineseminar
- [3] knowledgebase.national.com
- [4] www.national.com/design
- [5] www.national.com/rap

All links are also accessible from the National Semiconductor homepage: www.national.com

Precision Function Generator

MAX038 goes SMD

Klaus-Jürgen Thiesler

Although surface-mount parts are not the easiest to handle, the reward in test and measurement equipment is increased accuracy.

Integrated precision function generator type MAX038 is now an old faithful with a history of ten years. In the June 1995 issue we described a full-blown function generator built from standard size parts and using what is now considered a large PCB. The project was hugely successful and PCB sales reached several thousands. In 1995, the use of SMDs in Elektor circuits was more or less prohibited because the advantages of a smaller board did not outweigh the disadvantages of problematic supply and mounting methods.

Today there's no way you can avoid SMDs anymore, however we generally do not use them unless they serve a good purpose, or if the component we wish to use is simply not or no longer available in 'leaded' form. Other compelling reasons to use SMS are the ongoing miniaturisation of circuits and near elimination of stray capacitance and inductance (particularly in compact RF gear).

In some case, however, SMDs simply serve advancing technology — if you build the function generator from SMD instead of leaded parts and ensure low-inductance (i.e., *short*) PCB tracks then the instruments' technical

specifications as well as its frequency range can be improved dramatically. A digital frequency range switch in combination with multilayer ceramic capacitors (MLCC) in SMD technology not only improve the general performance of the MAX038 chip but also extend its frequency downwards to below 0.1 Hz and upwards to over 20 MHz. Such improvements we feel are worth just that extra effort in building up the circuit.

Two easily realised design aspects will help to unlock the full potential of the MAX038:

- an optimised PCB layout with the shortest possible copper tracks to keep stray inductance and capacitance to a minimum;
- SMD parts are marked by lower temperature coefficients and closer tolerances.

The circuit and PCB layout presented here do not represent a complete construction project. Rather, the publication aims at providing a few useful tips when you really want to juice the MAX038 for maximum performance. Hence Mr. Thiesler's contribution fills this month's Start Here pages.

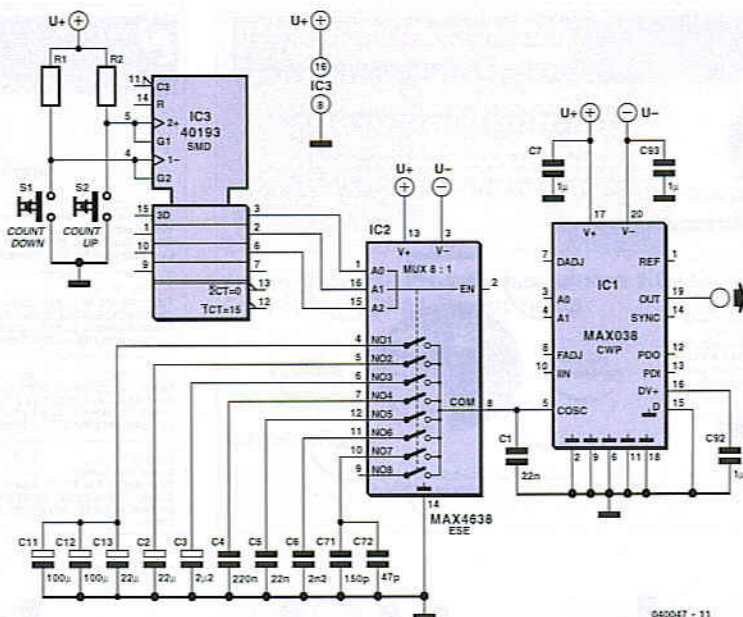

Figure 1. Suggested circuit diagram for a precision function generator based on the MAX038 (now in an SMD case).

Range switch

Instead of the mechanical range switch we propose an electronic CMOS analogue switch type MAX4638ESE, an 8-1 multiplexer that, depending on its control, connects the various frequency-determining capacitors to the internal oscillator. In the highest frequency range (20 MHz), it is essential for capacitor C8 to be connected directly to the MAX038 — and not by way of the multiplexer. Using the SMD stuffing in SO16 and 0815 enclosures this can be realised without problems. The ground side of C8 has to be connected directly to pin 6 (GND) — the other ground pins are unsuitable for that purpose.

The switching currents through the frequency determining capacitors are really low and the oscillator voltage (COSC) is just -1 V (at a supply of ±5 V). This makes the selection of the CMOS switch rather easy. Much more critical however is the PCB layout; 1 cm of 1-mm wide copper track representing an inductance of 7 nH. Long wires cause large stray capacitances and that is where SMDs are clearly superior to their leaded counterparts. As a bonus, SMDs are manufactured to closer tolerance specifications.

MLC capacitors

Solid, leaded, capacitors in the microfarads range are every expensive, inaccurate and bulky components and it is not surprising to see they are rarely used these days. SMD multilayer ceramic chip capacitors (MLCCs) are much more accurate, tiny and cheap mainly because they are manufactured by the millions for use in mobile phones. Mind you, MLCCs are not a new development — in fact they have been around for at least ten years. The codes stated in the parts list indicate the dielectric (X5R...) and the case shape (1210).

For the low end of the frequency range a 100-µF MLCC with a working voltage of 6.3 V is used with excellent results. Its ESR (equivalent series resistance) is stunningly low at less than 10 mΩ. A 100-µF, 68-µF and 22-µF MLCC stacked to make a neat pile was measured and found to have an equivalent capacitance of 216 µF.

Large value ceramic capacitors in X5R technology have a typical tolerance of ±20%, as opposed to +80/-20% for Y5V types. RF ceramic capacitors like the 22-pF MLCC with COG structure and a maximum deviation of 0.5 pF are manufactured by, among others,

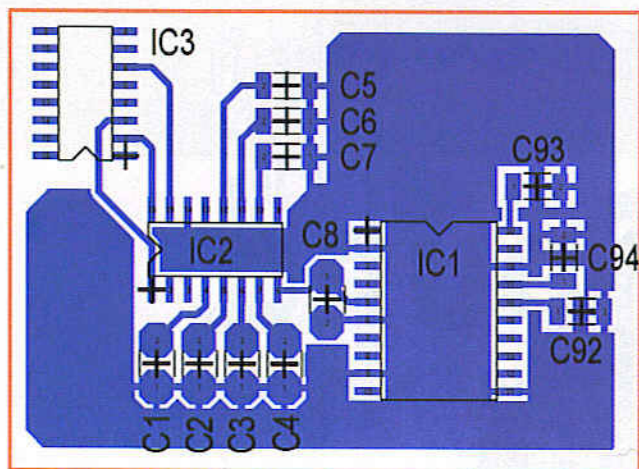

Figure 2. Proposed PCB layout featuring ultra-short tracks and an 8-way all-electronic frequency range switch.

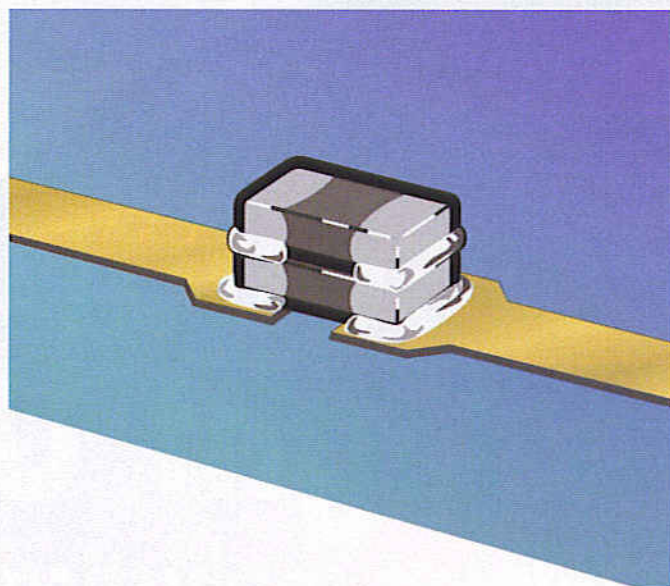

Figure 3. Capacitor stacking — no problem with MLCCs.

Taiyo Yuden. Although the temperature coefficient of just ± 30 ppm (Class 1) is a bit over the top for our application, it does demonstrate the technological advances made by passive component designers. The author found that Reichelt (www.reichelt.de) supplies an assortment of 0805 style COG ceramic chips at a reasonable price.

Adjustment requires a capacitance meter to be able to select the frequency determining capacitors for desired value, or combine a nmef of them to arrive at the desired values. These chip capacitors may be stacked onto each other and occupying just one pair of PCB solder pads. As you can see from Figure 3, the 'tower block' method helps to keep copper tracks as short as possible. For a change, you'll find that the trusty solder iron has the edge over industrial mounting methods like flow soldering or hot air! Although SMD components in 0805 and 1210 cases are really small, they can still be soldered manually if you have a steady hand.

(040047-1)

Components list:

Capacitors:

C1a, C1b = 100 μ F ceramic MLCC	Y5V	1210
C1c, C2 = 22 μ F ceramic MLCC	X5R	1210
C3 = 2 μ F2 ceramic MLCC	X7R	1210
C4 = 220nF ceramic MLCC	X5R	0805
C5 = 22nF ceramic MLCC	X7R	0805
C6 = 2nF2 ceramic MLCC	COG	0805
C7a = 150pF ceramic MLCC	COG	0805
C7b = 47Fp ceramic MLCC	COG	0805
C8 = 22pF ceramic MLCC	COG	0805

Semiconductors:

IC1 = MAX038CWP (SO-20)
IC2 = MAX4638ESE (SO-16)
IC3 = 40193 (SMD)

n	Frequency ranges		
	@ 2.2×10^n pF	@ 4.7×10^n pF	@ 1.0×10^n pF
8	0.1 - 1 Hz	0.04 - 0.4 Hz	0.2 - 2 Hz
7	1 - 10 Hz	0.4 - 4 Hz	2 - 20 Hz
6	10 - 100 Hz	4 - 40 Hz	20 - 200 Hz
5	100 Hz - 1 kHz	40 - 400 Hz	200 Hz - 2 kHz
4	1 - 10 kHz	400 Hz - 4 kHz	2 - 20 kHz
3	10 - 100 kHz	4 - 40 kHz	20 - 200 kHz
2	100 kHz - 1 MHz	40 - 400 kHz	200 kHz - 2 MHz
1	1 MHz - 10 MHz	400 kHz - 4 MHz	2 - 20 MHz

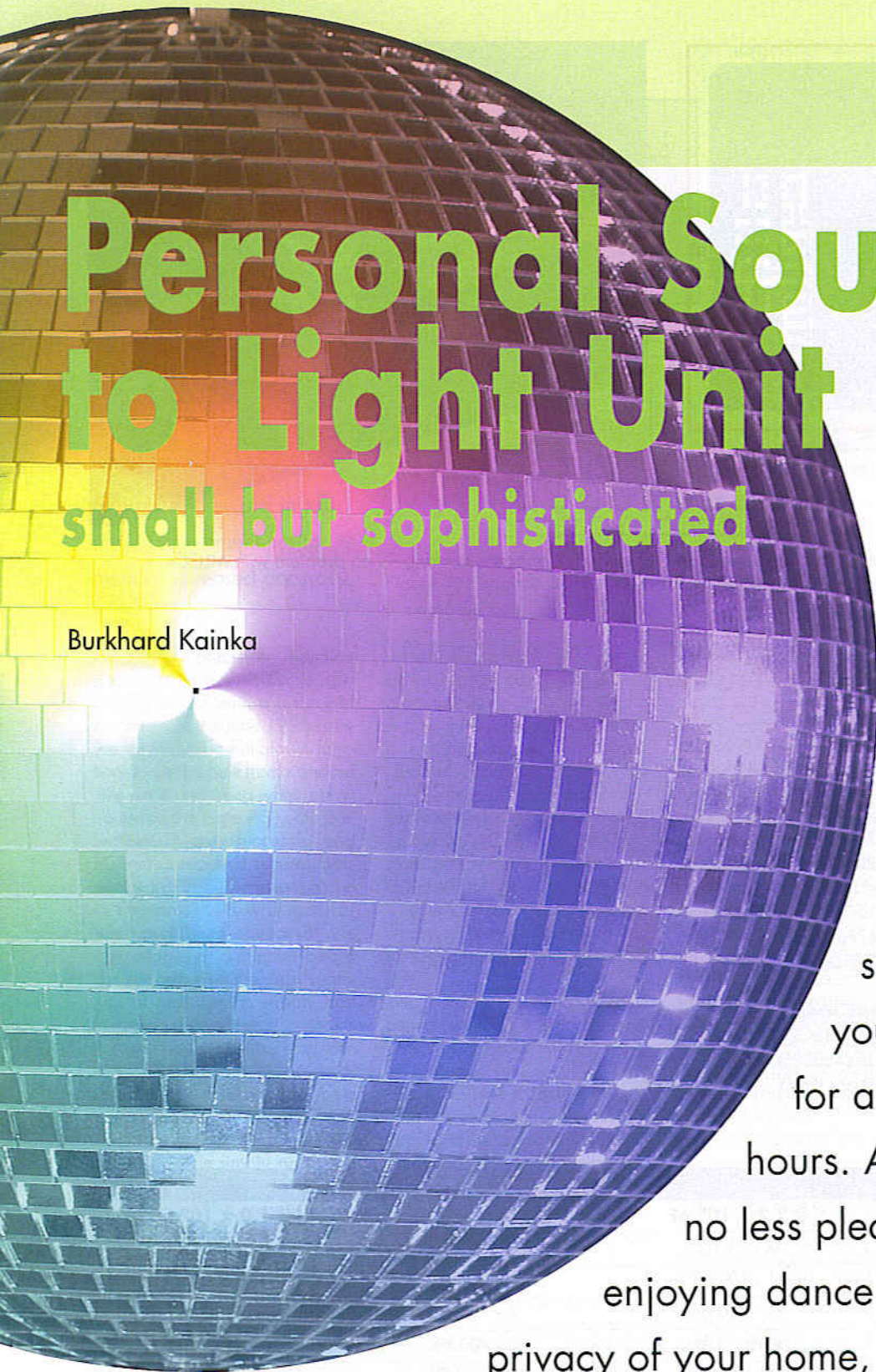

Personal Sound to Light Unit

small but sophisticated

Burkhard Kainka

Disco nights are great fun from time to time but you don't want to overdo it in regard of the sound volumes you're exposed to for a couple of hours. Arguably there's no less pleasure in enjoying dance music in the privacy of your home, study or student digs. However, the true disco feeling is not obtained without a matching sound to light unit, so here's a really small version.

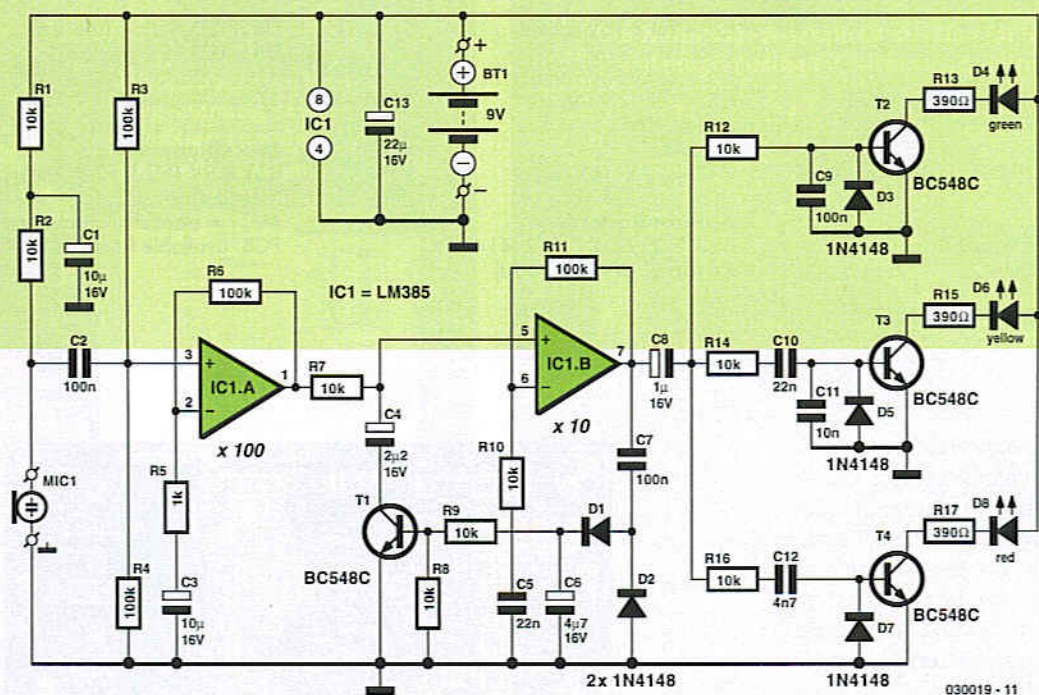

Figure 1. The circuit of the sound to light unit consists of a controlled-gain amplifier followed by a 3-way frequency splitter.

A sound to light unit converts music signals into light pulses. In most cases, three channels are used to cover different frequency ranges. The bass channel will then indicate the 'beat' of the music by a more or less rhythmical flash, while the two other channels represent the higher frequency ranges of the music channel.

The 'private' version of a sound to light unit discussed in this article employs three coloured LEDs instead of powerful flashing lights or floodlights as used in most discos. For the rest, it has practically the same functionality as the 'real thing' experienced on Saturday nights. However, a direct connection to the music amplifier is not necessary as the unit we've in mind has been designed to pick up the sound information through a microphone. Another peculiarity of the circuit is the automatic sensitivity adaptation to the music volume detected. In this way the circuit can work without any controls.

The circuit draws an average current of just 20 mA and works happily off a 9-volt PP3 block battery. However, the low current requires super bright LEDs to be used to ensure sufficient brightness.

Amplify it

High amplification is required to enable the tiny signals produced by an

electret microphone to be turned into bright flashes from LEDs. The circuit diagram in Figure 1 shows that we employ two operational amplifiers with a total gain of about 1000 times. The input of the first opamp (IC1.A) is connected to the electret microphone capsule via coupling capacitor C2. The microphone is given a certain DC bias level obtained from the 9-V supply rail by resistors R1 and R2. R1 together with electrolytic capacitor C1 decouple the supply voltage for the sensitive microphone while R2 equals the microphone impedance. Capacitor C2, then, ensures that the microphone bias level does not appear at the opamp input. In other words, it will only pass the alternating component, which is caused by sound picked up by the microphone. The + input of the opamp has its own bias voltage supplied by potential divider R3-R4. Because the two resistors have the same value, the supply voltage is effectively halved, i.e., 4.5 V exists at the junction of R3 and R4 (assuming a nominal 9 V supply). This bias voltage will also exist at the output of the first opamp and, because of R7, at the input of the second one (IC1.B) whose output will also copy this dc level. In this way, R3 and R4 keep both opamps biased at half the supply voltage. Both opamps are used in the non-inverting configuration

hence provide unity ($\times 1$) dc gain.

For alternating signals, however, the gain is much greater. In the case of the first opamp, the gain is determined by the ratio between resistors R6 and R5, or R11/R10 for the second opamp. Just look at the relevant resistor values and you'll discover that IC1.A is configured for a gain of 100 and IC1.B for a gain of 10.

The signal level at the output of IC1.B is rectified by D1 and D2, smoothed by C6 and then used to drive n-p-n transistor T1. To the signal voltage at the output of IC1.A, the combination of R7 and T1 looks like a voltage divider. With rising signal levels, the rectified voltage on C6 also rises and the transistor is driven harder because of the larger base current supplied by R9. The result is a lower resistance in the transistor and consequently a lower AF signal behind R7.

You may wonder why we did not use an n-p-n transistor without direct current in the collector circuit. Alternatively you might have expected to see a FET at this position, its drain-source junction acting as a controlled resistance. It is less known that virtually the same function may be obtained from a regular switching/AF transistor like the ubiquitous BC548C. An n-p-n transistor, too, represents a variable resistance that can be controlled with

Components list

Resistors:

R1,R2,R7-R10,R12,R14,R16 = 10kΩ
 R3,R4,R6,R11 = 100kΩ
 R5 = 1kΩ
 R13,R15,R17 = 390Ω

Capacitors:

C1,C3 = 10µF 16V radial
 C2,C7,C9 = 100nF

C4 = 2µF 16V radial
 C5,C10 = 22nF
 C6 = 4µF 16V radial
 C8 = 1µF 16V radial
 C11 = 10nF
 C12 = 4nF
 C13 = 22µF 16V radial

Semiconductors:

D1,D2,D3,D5,D7 = 1N4148
 D4 = LED, green (see text)

D6 = LED, yellow (see text)
 D8 = LED, red (see text)
 IC1 = LM385N (with socket)
 T1-T4 = BC548C

Miscellaneous:

BT1 = 9V PP3 (6F22) battery with clip-on lead
 MIC1 = electret microphone
 PCB, available from The PCBShop

hin a certain range. However, for a low-distortion volume control, only a tiny signal level (of the order of millivolts) may be applied to the collector. This condition is not satisfied here as the output voltage is regulated to about 1 V_{pp}. If the second stage has a gain of 10, about 100 mV_{pp} can be found at the collector. At such a level, distortion occurs that will not be acceptable in other applications. No problem for the sound to light unit, however, because the output signal is used to control LEDs than drive an audio amplifier. If you do want to use such a 'volume control' for audio applications, you should make sure a much smaller signal level is handled, which is probably easiest realised by moving the automatic volume control towards the circuit input.

Filter

The output signal supplied by the second opamp drives the LED controls by way of simple filters. Each LED driver stage consists of a transistor (T2, T3 and T4). To prevent the transistor bases from being charged with negative levels, anti-parallel diodes (D3, D5, D7) are used on each base terminal. Each transistor is only actuated on the positive half cycle of the drive voltage. Overall, however, the higher frequencies do cause an impression of average brightness.

The filters consist of simple RC networks broadly dimensioned for a cut-off frequency using the formula

$$f_c = 1 / (2 \pi R C) \quad [\text{Hz}]$$

For example, the low-pass section R12/C9 is dimensioned for about 160 Hz using 10 kΩ (R12) and 100 nF (C9). All lower frequencies in the music signal will therefore pass through this 'channel'. The mid-tone channels contains a combined high-pass / low-pass

filter R14/C10+C11. The treble channel is driven by a simple high-pass R16/C12. If necessary the cut-off frequencies may be changed to suit individual requirements and that's easiest done by making small changes to the capacitor values.

Printed circuit board

If the circuit of a relatively simple design, the actual construction of the sound to light unit is made even simpler by a printed circuit board (Figure 2). The two opamps we've discussed are contained in a single IC type LM385, which is best fitted in an IC socket (look at the notch in the IC body). The single-sided PCB has no wire links. No problems are expected to arise if you watch the polarity of the diodes, electrolytic capacitors and

LEDs and work carefully all the way. The electret (or 'condenser') microphone insert can be almost any available type as long as it has two terminals.

The maximum LED current amounts to about 18 mA so the circuit is suitable for LEDs described as 'standard', 'bright' and 'superbright'. Using the latter the effect of the 3-way filtering is more pronounced, while for a relatively small room with not too much light ordinary LEDs will be found to be perfectly suitable. If you decide to use low-current LEDs, the value of series resistors R13, R15 and R17 should be increased to 3.3 k or even 3.9 k. The resulting reduction in current consumption will enable your 9-V battery to last much longer.

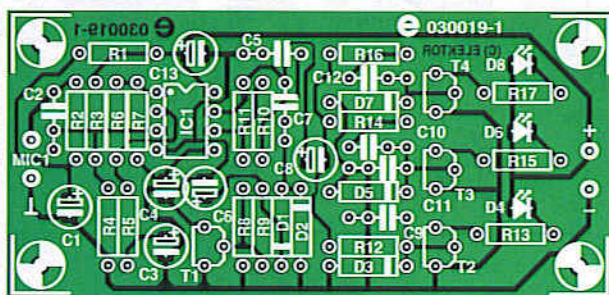
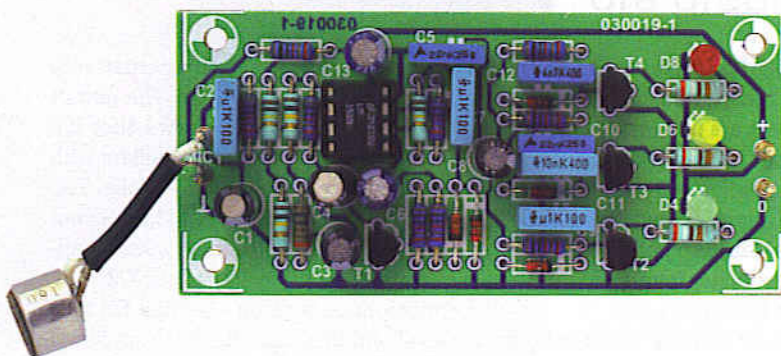

Figure 2. The single-sided PCB has no wire links.



(030019-1)

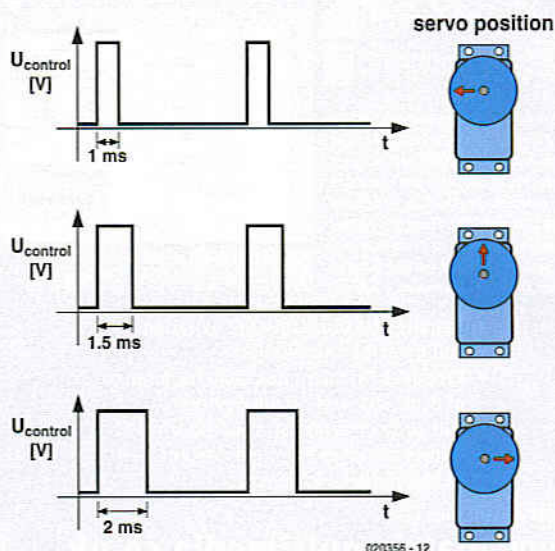
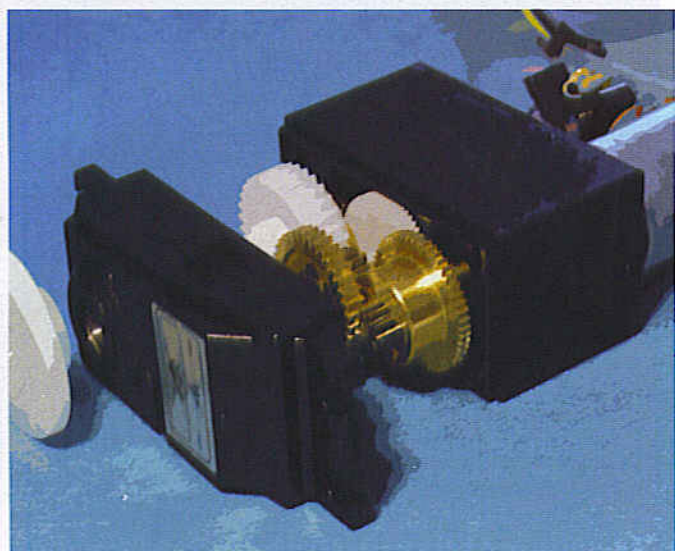

Figure 1. Spindle (actuator) position as a function of pulsewidth.

Digital Motors

intelligent drive for servos

Giel Dols

Analogue servos are really ingenious bits of hardware. But there's an even better alternative: the digital servo! Based on the operation of the 'normal' servo we tell you what's so much better about the latest digital ones.

A servo is a combination of a dc, ac or brushless motor with a position detection circuit. In modelling and robotics, we usually find three-wire dc servos. Such a servo then consists of dc motor, a reduction gearbox and two mechanical 'stops' preventing the spindle from turning beyond extreme positions. Usually, the servo also contains a potentiometer

that enables the position of the spindle to be communicated to a small piece of electronics. The circuit, then, is the link between the motor, the measured position and the real world. The three wires carry the supply voltage, ground and the drive signal to the servo. The drive signal — in RC modelling usually supplied by a

receiver — determines the target position of the servo spindle. If external forces (like air pressure on a model plane rudder) try to change the spindle position, the feedback in the control circuitry will counteract the movement and ensure the rudder remains in the desired position. As long as its drive signal remains unchanged, a servo will main-

tain the current spindle position, correcting it if necessary. Only if there's a change in the drive signal will the spindle move to a different position.

Operation

The drive signal consists of rectangular pulses with a swing of 5 V. The pulse period time is constant and the width of individual pulses determi-

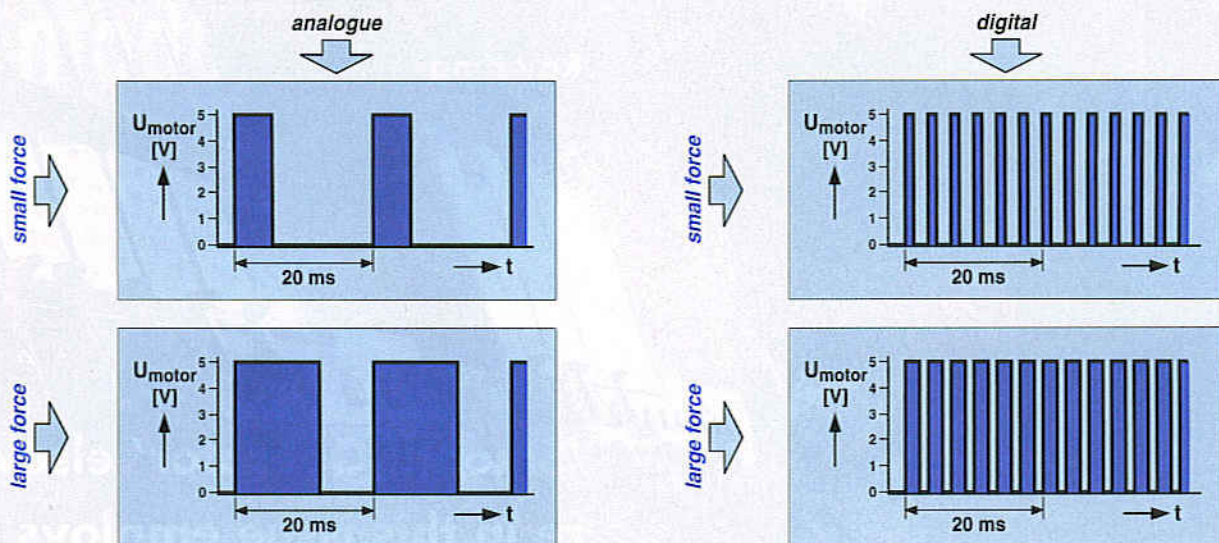

Figure 2. Motor voltage when a certain spindle position is maintained (left: analogue — right: digital).

ness the spindle position. The zero or home position of a servo corresponds to a pulse width of about 1.5 ms. Depending on the desired amount of spindle rotation, the control pulses are shortened or lengthened. However, the period of 20 ms is maintained all the time.

The servo actuator spindle is coupled to a potentiometer. Consequently, the potentiometer's wiper position not only indicates the spindle position but also equates to a certain pulsewidth. The internal electronics looks after this fixed relationship, maintaining the spindle position until a change in the drive signal pulsewidth occurs.

The digital way

In recent years, servos have seen great improvements — size, response time and actuator force have been subject to constant improvements. The latest development called 'digital servo' is an important step forward. In principle, the digital servo is

equal to its analogue ancestor. The only difference exists in the activities of a microcontroller constantly analysing the drive signal and if necessary driving the motor. The mechanical construction is the same as that of the analogue counterpart.

The use of a microcontroller offers significant advantages. As already mentioned, an analogue servo is capable of correcting its spindle position to counteract external forces. Not much will happen if the external 'disruption' is small, as small changes equate to narrow pulses. In many cases, the effective power fed to the motor under these conditions is too low to get the motor to turn so a certain amount of hysteresis is created: below a certain limit, the servo will respond in a non-linear fashion to disturbances in the spindle position. With digital servos, the microcontroller has been programmed to 'know' the motor's specific response and account for it in the way it is

driven. For example, the width of the pulses sent to the motor in response to a relatively small spindle movement will be larger than with an analogue servo. Because the software allows the processor to calculate the optimum amount and length of the drive pulses for a certain disturbance or desired position, a digital servo will show much faster accurate responses.

It's not just the 'intelligence' that makes the servo behave the way we want. A further difference with analogue servos is the use of much higher switching frequencies of the motor drive pulses. This not only benefits the accuracy, but also allows more power to be delivered as the motor can be 'on' more often. Extra power is not only practical in maintaining the existing spindle position, but also when moving to a new one because the sensor can accelerate much faster and reach the target position well before its analogue counterpart.

Disadvantage?

Increased energy consumption is a direct consequence of higher motor pulse speeds. This disadvantage should be duly considered when applying the new digital servos in any battery-powered equipment like model craft. Fortunately, the problem is far from insurmountable thanks to recent advances in battery technology.

(040041-1)

Rail

Ray King

'Smooth Operator' elsewhere in this issue employs model control servos to drive the turnouts on a model railway. One of its advantages is that it can be activated over a single wire making it ideal for computer control described... here! Rail Router is a hardware/software combination capable of controlling up to 127 turnouts.

Router

model train routing with a PC

The Rail Router hardware comes in two flavours: a **master** router board capable of directly controlling up to 15 devices and a **slave** board connected up via a ribbon cable and adding a further 16 turnout controls. The general layout of the system is illustrated in **Figure 1**. The master and slave circuits use the same printed circuit board stuffed to reflect the desired function. Slave routers are optional — if you are satisfied with 'just' 15 turnouts and/or semaphores then you're fine with just the master router.

A dual-purpose circuit...

The circuit diagram shown in **Figure 2** is unusual in that it shows the master as well as the slave circuit. Dashed outlines and connections are used to indicate the difference between the two circuits, which can be built on one and the same board. Electrically the difference between the two circuits exists in the presence or absence of jumpers and circuit parts. The MAX232 two-way RS232/TTL level converter, for example, is only required for the master function, which (as you may have guessed already) requires a connection with a PC running the specially written Rail Router control software (more about this further on). The RS232 port on the PC is connected up to the Rail Router master board via sub-D socket K17. Only Tx/Rx traffic is used, without handshaking. A PIC16F877 microcontroller is found at the heart of the master as well as the slave circuit. Although the micro is loaded with the one that the same software

for the master or slave function, it actually selects between two different code chunks by looking at the logic level you've defined at port line RC5 by means of jumper JP1. The 16F877 ticks at 8 MHz as determined by quartz crystal X1 and its loading capacitors C1 and C2.

The master and slave router boards require a power supply of 8 V to 15 V DC which can be provided by a small mains adaptor or from a DC outlet on one of the railway speed governors.

Master operation

The PIC micro continuously monitors the incoming serial information, determining whether the device specified in the command is comprised in the first 15 turnouts. If so, it changes the state of the turnout control (via K2-K16). If not, it passes the information over to buffer IC3 and from there to connector K18 for slave units to test. Each output connector (K1-K16) on the router board comprises an unregulated supply (V+) ground and the control lead as required by the 'Smooth Operator' servo control circuits. Note that Output #1 (K1) is not used by the master configuration. It is planned to employ it at a later stage for enhanced facilities.

Slave operation

The operation of the slave board is similar to that of the master but simpler because of the absence of the RX/TX serial interface with the PC. The unique address of each slave board is determined by the settings of DIP switch S1. Setting the address to 001, for example, allows the slave board to operate turnouts 16 through 31, where code 001 is RE2 = 0; RE1 = 0 and RE0 = 1 on the PIC.

... and a dual-purpose circuit board

As already suggested by the circuit diagram, the circuit board designed for the Rail Router system can act as a master or a slave, depending on how it is populated. The two different component stuffing plans are given in **Figures 3a** (Master) and **3b** (Slave). Carefully study the parts list and the component overlays to avoid hard to find problems. If necessary, refer back to the circuit diagram. All components on the two boards are regular-size devices and construction is therefore not expected to cause any difficulty if you take your time and pay attention to polarised components in particular (ICs, transistors, electrolytic caps). We recommend using a good quality socket for the PIC device(s) as it (they) will be the most expensive part(s) in the circuit.

The PIC software

We can be very brief about the software run by the PIC micro(s) used in this project. Do-it-yourself programmers among you will be pleased to know that the complete annotated source code files supplied by Ray King are available free of charge from our website under ref. **030403-11**. Simply download them, compile and then program your own 16F877 chip. Alternatively use the hex code directly. Those of you without the means or wherewithal to burn your own PIC chip may resort to our Readers Services who supply ready-programmed PIC chips for this project under order code **030403-41**.

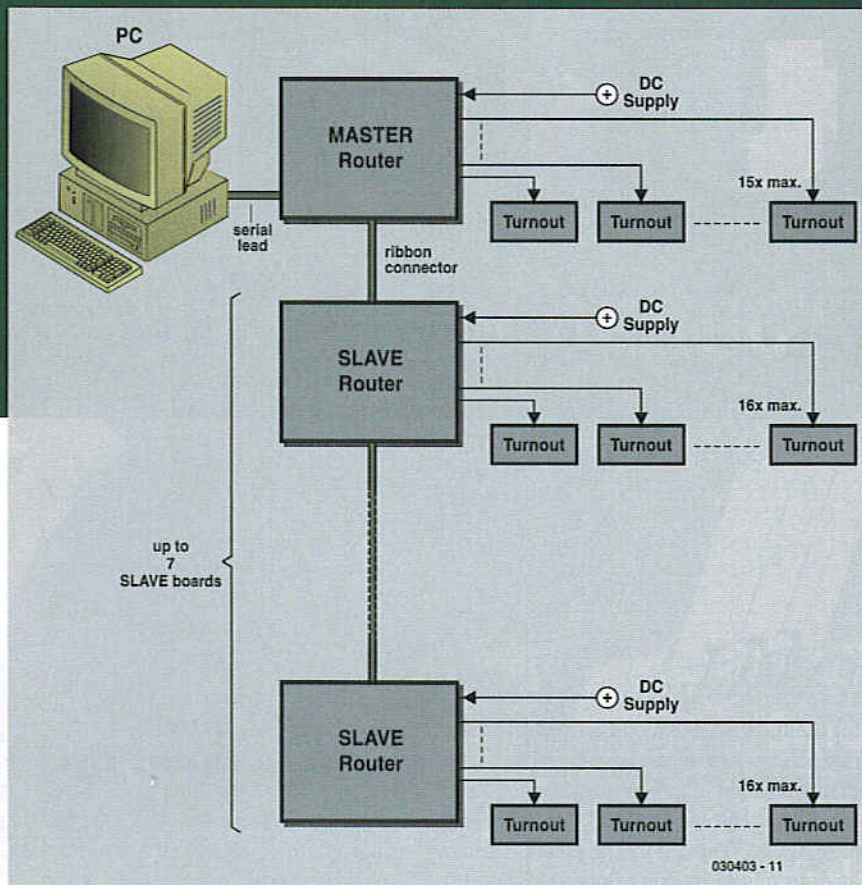

Figure 1. A complete system would be set up like this. The boxes marked 'turnout' represent a 'Smooth Operator' unit.

Rail Router for the PC

A screenshot of the Rail Router software running on a PC is shown in Figure 4. Any number of track layout

designs may be stored on the PC and loaded when the Rail Router program is launched, or at any time during a session. The software written by Ray offers the facility to design and alter the railway layouts before saving them

to disk. The baud rate to the master router is 9600 bits/s. The PC software was written in Visual Basic 6 (VB6). The source code (.VBP and components) as well as the executable version are included in the 'software package' for the project, ref. 030403-11. Simply run the railrouter.exe file and the program will be installed on your computer. The latest updates and hardware additions may be found at Ray King's website.

Design a track layout...

Click on the 'Change Layout Design' button and the design screen will appear. Click on any square in the layout area, then click on the required symbol to be put in this square. Continue adding symbols until your layout is complete. Make sure all sidings as well as roads in and out of the layout end

COMPONENTS LISTS

Master Router

Resistors:

R1 = 4kΩ
R2, R3, R4 = 10kΩ
R5 = 47kΩ

Capacitors:

C1, C2 = 22pF
C3-C7, C9 = 10µF 25V radial
C8, C11, C12 = 100nF
C10 = 1µF 16V radial

Semiconductors:

IC1 = PIC16F877-20/P, programmed, order code **030403-41**
IC2 = MAX232
IC3* = 74HCT241
IC4 = 7805

Miscellaneous:

JP1, JP2 = jumper
K2-K16 = 3-way SIL pinheader

K17 = 9-way sub-D socket (female) angled pins, PCB mount
K18* = 10-way boxheader
K19 = 2-way PCB terminal block, lead pitch 5mm
X1 = 8MHz quartz crystal PCB, order code **030403-1** (see Readers Services page)
Disk, all project software (PIC & PC), order code **030403-11** or Free Download

* only required when a Slave Router is connected

Slave Router

Resistors:

R2, R3 = 10kΩ
R5-R8 = 47kΩ

Capacitors:

C1, C2 = 22pF
C9 = 10µF 25V radial
C12 = 100nF
C10 = 1µF 16V radial

Semiconductors:

T1 = BC550
IC1 = PIC16F877-20/P, programmed, order code **030403-41**
IC4 = 7805

Miscellaneous:

K1-K16 = 3-way SIL pinheader
K18 = 10-way boxheader
K19 = 2-way PCB terminal block, lead pitch 5mm
S1 = 3- or 4-way DIP switch
X1 = 8MHz quartz crystal PCB, order code **030403-1** (see Readers Services page)

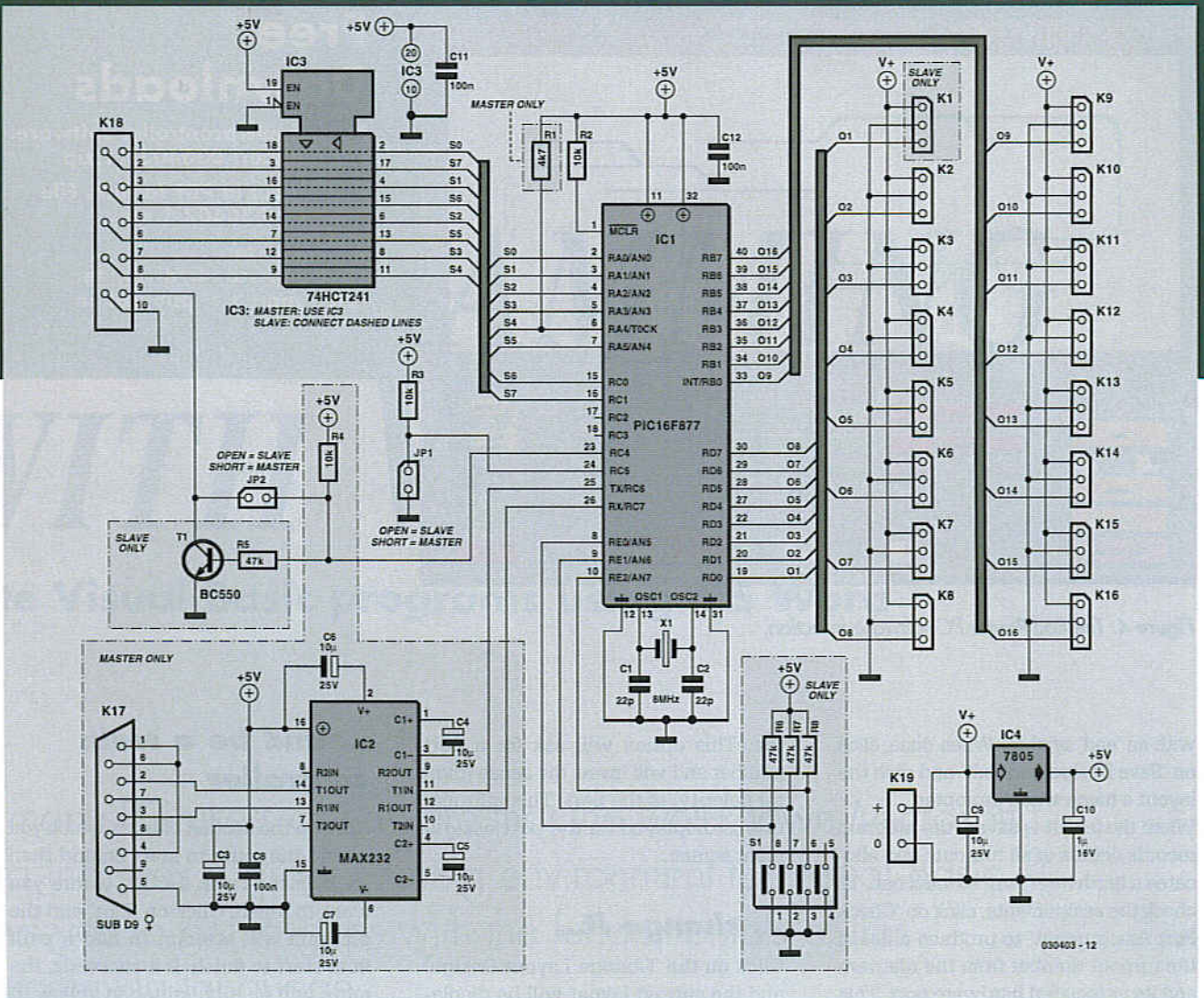

Figure 2. Combined circuit diagram for the Master and Slave Router configurations.

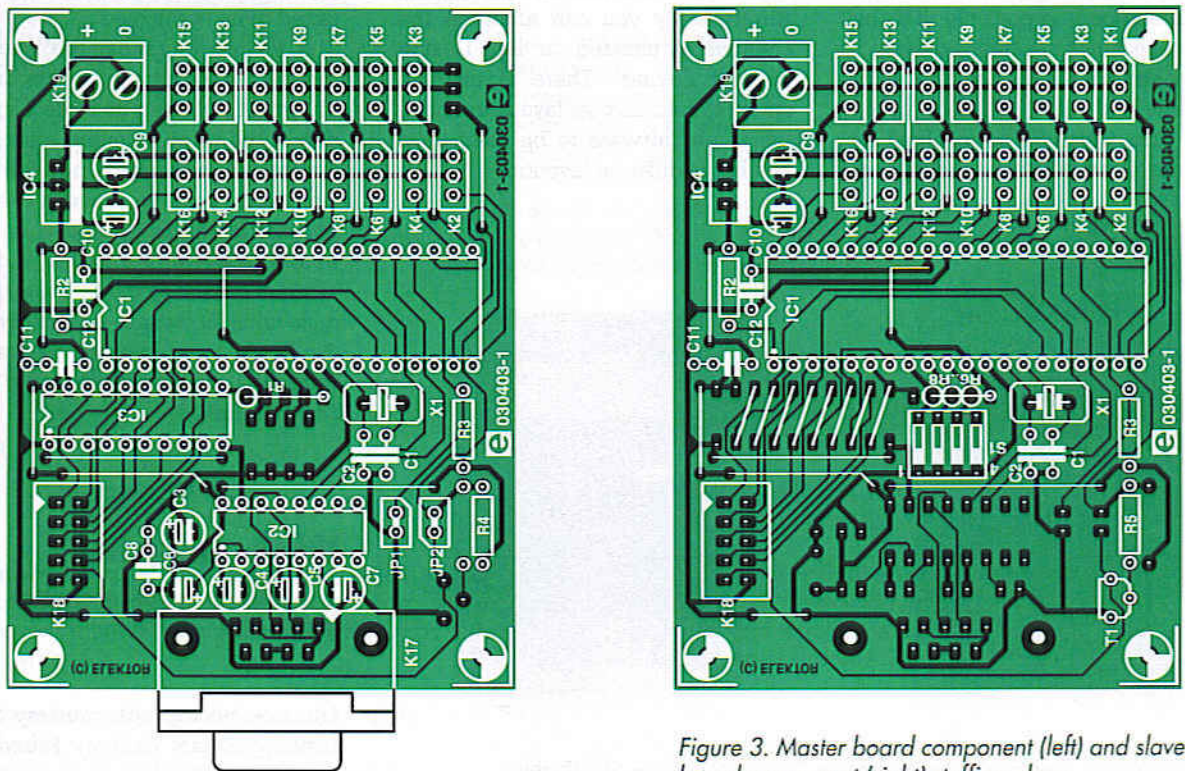

Figure 3. Master board component (left) and slave board component (right) stuffing plans.

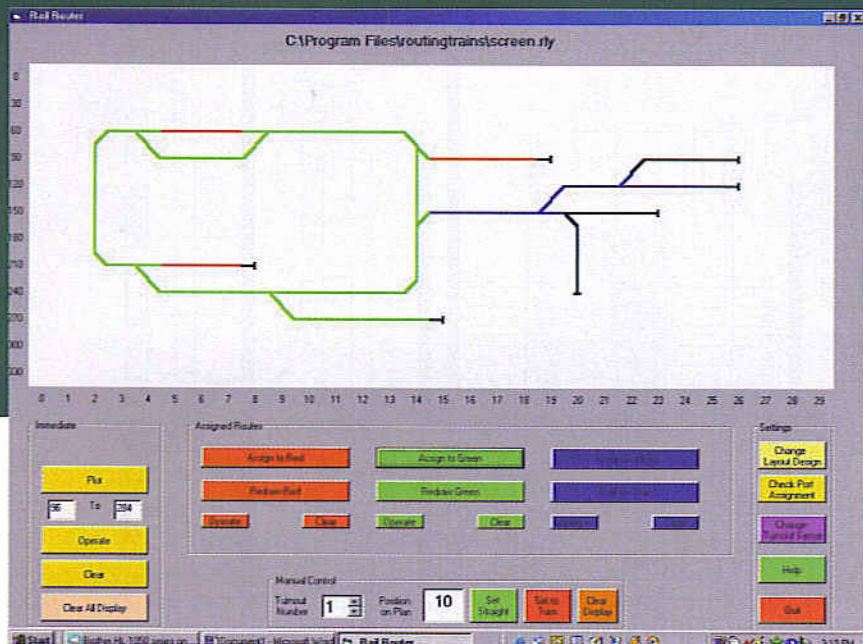

Figure 4. The Rail Router PC software in action.

with an 'end' symbol. When done, click on 'Save Design and Exit' and give the layout a name when prompted. When the layout is saved, the program records details of all turnouts and allocates a hardware 'port' to each one. To check the assignments, click on 'Check Port Assignment' to produce a list of the turnout number from the diagram and its associated hardware port. This hardware port (i.e., K2-K16 on a master board, or K1-K16 on a slave board) should be wired to the 'Smooth Operator' control for that particular turnout. On installation it is possible that the turnout mechanism works in the opposite sense to the software, that is, if 'ahead' is selected the turnout moves to the turn. This can be resolved by using the 'Change Turnout Sense' but-

ton. This option will ask for a port number and will invert the sense (digital polarity) of the port. This information is displayed on the port assignment screen.

... change it...

Click on the 'Change Layout Design' and the current layout will be displayed. You can add or delete symbols to change the layout as necessary. Next, save the modified design by clicking on the 'Save and Exit Design' button. Alternatively you can abandon the changes by clicking on 'Exit Design without Saving'. There is also an option to load another layout, enabling the same software to be used for a number of different layouts.

Free Downloads

PC and microcontroller software.
File number: 030403-11.zip

PCB layout in PDF format. File
number: 030403-1.zip

www.elektor-electronics.co.uk/dl/dl.htm,
select month of publication.

... and be a train controller

Click on the section of track which you intend the route to start on and then click on the track section where you want to finish. Click on 'Plot' and the program will attempt to find a path from start to finish. If it succeeds, the route will be highlighted in yellow. If not, 'No Route Found' will be visible. If the routing is successful but you feel there is a better way through then simply click on 'Plot' again until your preferred route is selected.

The yellow route can be operated directly using the appropriate button, alternatively it can be stored against one of the three coloured routes and operated at any time. Up to three different routes can be stored in this way. Avoid starting or ending your route from a crossover, turnout or end sign as these can cause the software to produce unusual results — normally false 'No Route' messages, which, come to think of it, is not as bad as 'No Train Services Today'.

(030309-1)

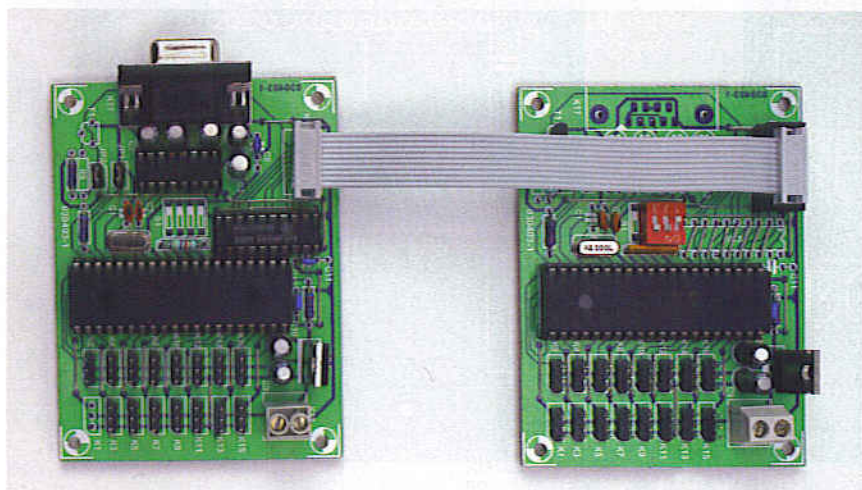

Figure 5. Master Router coupled to a Slave Router by a piece of flatcable.

Web pointer

[www.king.ray.btinternet.co.uk/
index.htm](http://www.king.ray.btinternet.co.uk/index.htm)

Location photograph courtesy South
Limburg Steam Railway Foundation
(www.zlsm.nl)

PROGRAMMING WITH WORD

write Visual Basic programs using MS Word

Not many PC users are aware that the well-known Microsoft Word includes a programming environment for Visual Basic. It allows you to get to grips with the fundamentals of this programming language.

This article will be of particular interest to those of you who don't have the complete Visual Basic package, but who would still like to play with a programming language under Windows. The trick here is: use **Visual Basic for Applications**, which is available in Word as well as Excel.

Step 1

Start Word. All the screendumps and programs shown here were made using Word 2000, but other versions such as Word 97 work just as well!

Step 2

From the *View* menu click on *Toolbars*. Then select *Visual Basic*, as shown in figure 1.

Step 3

The *Visual Basic* toolbar appears (figures 2 and 3).

Step 4

Now we'll make a button called **CommandButton** (figure 4). To look at a list of the properties of the button you have to position the mouse cursor over the button, then right-click on it and select *Properties*.

A new window pops up containing all the properties of the object (figure 5).
The two most important properties are *name* and *caption*.

Give a name to the button, which in our example is **Button-TestMessage**.

Replace the text on the button with **Click on this button!**. You can also change other settings, such as the size, font, background colour, background picture, etc.

As an aside, Visual Basic has many windows that are clearly laid out, or not! That is left to the user, but try not to get confused by all those open windows.

Step 5

Double-click on the button.

The Visual Basic editor opens. The procedure *ButtonTestMessage_Click* is created, if it didn't exist already, and the cursor appears **HERE**, where you will write your program (figure 6)!

This procedure is run with every click on the **Button-TestMessage** button.

Or more precisely, the procedure *Click* is linked to the object **ButtonTestMessage**, of type *CommandButton* (also described as: belongs to the *CommandButton* class).
The code for this procedure is entered here.

Step 6

Enter the line: *MsgBox ("You've clicked here!")* (figure 7a).

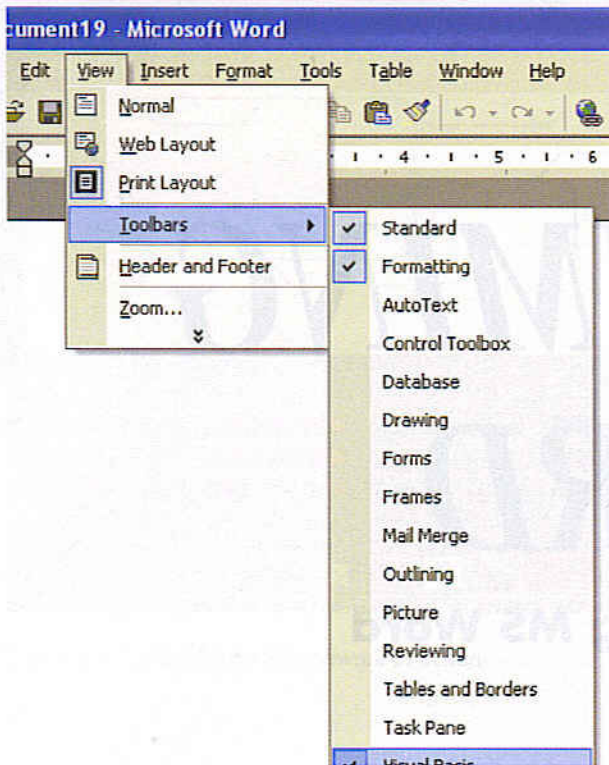

1



4

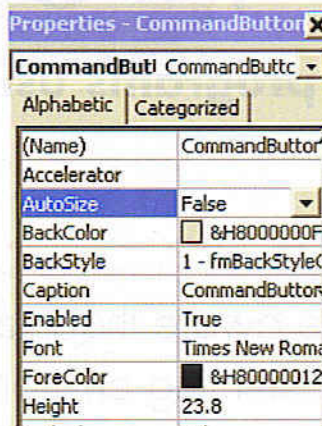

Name of the button you're about to create. Choose an unambiguous and clear name stating its function. For example: 'LightSwitch'.

Text appearing on the button. Do not confuse it with its functional name.

5



Click on the 'Control Box' icon.

Activate 'Design Mode'.

2

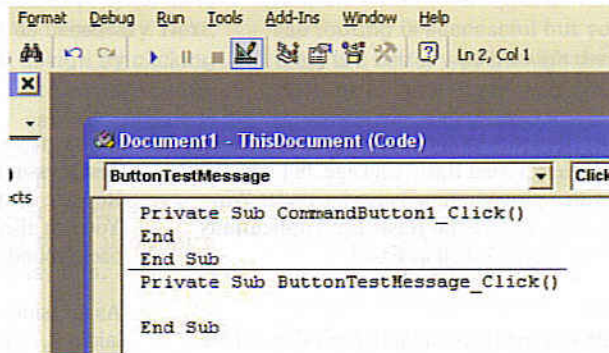

6



3

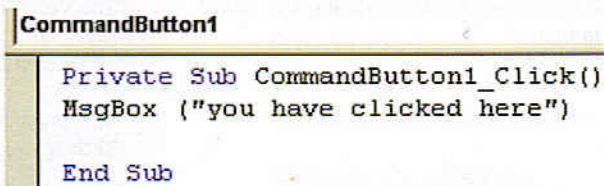

7a



7b

Step 7

Return to Word, using Alt-Tab for example, and return to Run-mode by deselecting the two icons on the Visual Basic toolbar (figure 7b).

You can also minimise the *Visual Basic* toolbar if you want to have a clear desktop, but you will have to enable it again if you want to continue programming.

Step 8

Save the file in Word format and test how it runs.

Summary

A small program can be written in seconds using MS Word. You should now have an idea of all the possibilities it offers. The same method can also be used in MS Excel to program in Visual Basic: create windows with buttons, input fields for text or data, pictures, etc. Show the information in graphs, personalise the Word menu with user-defined commands, run other programs. It is also possible (although that really needs a separate article) to use API's under Windows, to program the parallel port for example. Complex programs that hide the standard menus can be written this way. The users will think that they're running a dedicated program, whereas the reality is that it runs under Word or Excel.

(040046-1)

Help, my program doesn't work!

Three possible solutions and some advice.

1. Security level.

If a button doesn't work you should first check that the security level has been set to 'Medium'. The setting of this level determines how Word deals with macros and Visual Basic code that are embedded in documents. Word always asks this question when a document is opened. A high security level gives you no choice and programs written in Visual Basic cannot be opened.

The security level in Word can be changed as follows:

- From the Tools menu click on **Macro** and then on **Security**.
- Select the **Medium** security level.
- Now save your work and close Word.
- Re-open the document.

When the document is opened, Word gives a warning that it contains macros. In this instance, we click on **Enable Macros**.

2. Problems when running a program.

Your program could contain a bug, which has to be tracked down.

The debugger is a utility that stops your program at the point where the error occurs! The screendump below shows a typical window that you could see.

The Visual Basic editor then opens automatically.

3. It still doesn't work.

It's possible that the cause of the problem lies elsewhere. Try the following: Save the program and close Word. Open the document again. Amazingly, this trick is often enough to get a program to work.

If none of these help, there is a large amount of information on various Internet sites and in discussion forums.

Internet links:

Further information on Visual Basic

<http://msdn.microsoft.com/vbasic/>

Visual Studio

<http://msdn.microsoft.com/vstudio/>

Source codes in VB

<http://www.vbcode.com/>

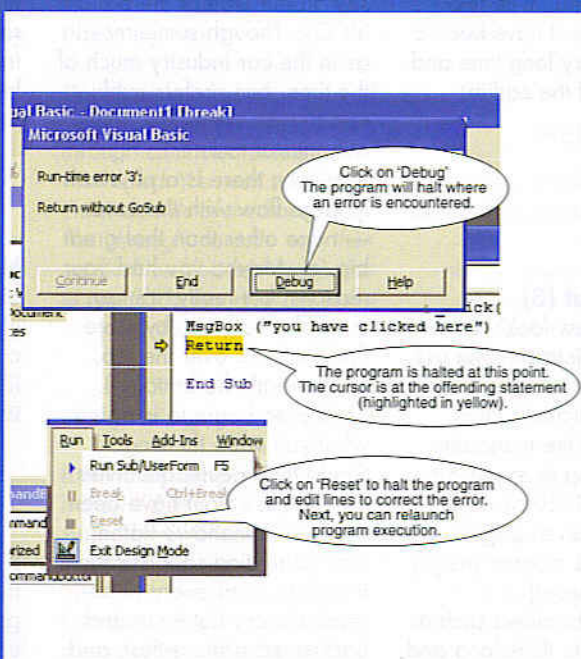
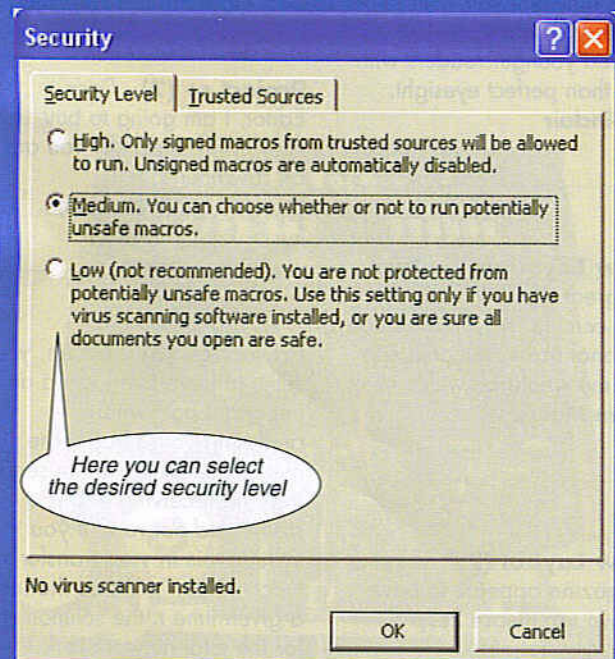

New Layout (1) I have been an Elektor reader since 1977. Your magazine has always kept up with times and this new format is no exception. Graphics/icon based format is the way forward and you could not have done better. One picture tells a thousand words. Elektor is simply the best.
Cemal Ozturk

New Layout (2) Hi, you have asked for feedback on the restyled Elektor magazine. I like the new style, it is reminiscent of the style used in the French and Italian electronics mags which I often buy when on holiday abroad. I would like to make one adverse comment, I do not like white characters on black background. The readability is very poor. If one must have a black background then yellow or magenta is quite good. I know this applies to the monitor and may well apply to the printed page. Perhaps you could do an experiment in a future issue and invite readers' comments. I have been a reader for very long time and have some of the earliest issues.
Mike Baker

New Layout (3) I'm afraid the 'new look' is a bit of a disappointment. The use of a full page image preceding major articles is clear attempt to fill the magazine without having to create content. The April 2004 issue has at least seven pages wasted in this manner (nearly 10% of the issue!). Magazine subscribers such as me will have to think long and hard when it comes to renew-

al time if this practice is maintained. I would rather see reprints of manufacturers' datasheets or even adverts than this. The new logo also instantly made me think of other ill-conceived re-branding exercises, such as BP's daft flower thing and the 'Royal Mail' madness during their brief 'Consignia' phase. Your old logo was instantly recognisable and yet not dated, why any company would wish to abandon years of branding is beyond me. I can only assume that there are people in the company spending too much time 'in meetings'. If all this seems negative, it is due in no small part to the high regard I have had for your magazine in the past. I would not wish to see *Elektor Electronics* go down the same path that others have, such as *Wireless World*. Change for the sake of change is madness.
Owen Grantham.

New Layout (4) As we say on our side of the pond, it's OK. Though sometimes, as in the car industry much of the time, one prefers evolution to revolution. Still, that's a matter of taste. However, there is a physical large flaw with the cover — none other than that great big 'e'. Maybe you had your reasons, but really, it's too clever by half, no, by more than half. It's over the top, no, beneath the bottom. I can't even begin to imagine what you were thinking. Could therapeutic quantities of Guinness Stout have been involved somehow? Rather than connoting sophistication, it calls to mind every oh-so-revolutionary but lame and hackneyed e-this, e-that, and e-the-other-thing that has ever

wended its way into an e-business e-advert e-cliché during the entire course of e-history. And — e-ek — it also reminds one of Microsoft's Internet e-xplorer, which ... let's not go there. It would be a considerable kindness for you to lose it just as soon as the e-novelty wears off.
Paul Schick

New Layout (5) I was very surprised to receive a copy of your restyled Elektor Electronics magazine. I am 54 years old and wear glasses, which were barely adequate to resolve the printed words on pages 5 onwards. When it came to reading the circuit diagram, I had to resort to using a magnifying glass to read the component values! I consider my eyesight to be average for my age and therefore assume that your team are much younger than me and therefore have better eyesight? My advice to you is to not proceed with this mini version if you wish to retain your older readers and indeed younger readers with less than perfect eyesight.
C. Sinclair

New Layout (6) I think it's great. Keep the good articles coming. Anything of educational basics for amateurs like me would be welcome.
Brian Moore

New Layout (7) The magazine appears to have grown up. Please keep it in your new format.
Edward Williams

Project c+ (1) Dear Jan, referring to the 'time inversion' article, The oscillograms in the article fail to use a time reference in order to locate ourselves in time. At the time of pressing the trigger (to initiate the approximate 1-second pulse to drive the pulse shaper) we should establish the reference on the oscilloscope 1 and 2 (channels B). At the moment it seems that the very long transmission line is a momentary short circuit to the poor overloaded opamp... the wave travels to the receiver shows itself on scope 2 and LED, then travels back to the source and at last makes the led light up. Of course there is a delay as the signal has travelled twice the distance. Nice try.... As I was looking for your email address I suddenly thought of the month... I hope some people did not trim too much. I like the touch with the high precision parts. Thank you for a fantastic magazine.
G. Brennet (by email)

Project c+ (2) Dear Editor, I am going to buy shares in Project c+. You are on a winner!
Don Phelps (by email)

Project c+ (3) Hi Jan, you seem to have overlooked an important part when analysing your circuit. The connection between the sending and receiving end is a *distributed network*. If you include this in your transfer-function, you will find that at a given time t , the solution for the total network is 040104, and the solution for

the sending part alone is 040204. It is quite obvious that 040104 is just one time unit ahead of 040204. I hope this has clarified the obvious.

Knut Bakke (by email)

Your projects, my projects

Dear Sirs, I have been a long time reader of Elektor, and would like to thank all Elektor (sic) staff for their superb circuits.

Your April 2004 magazine is a success and with each new issue you prove that electronics can be conveyed in interesting ways.

My favourite pastimes are audio and music and I've actually built many of your circuits. Some of these may be seen on the photographs on the enclosed CD-ROM. Equipment cases, screen prints and loudspeaker cases are all home made.

As I enjoy every good circuit you provide and build lots of them, I thought I'd show you a few examples of finished equipments.

D. Bozanic

The photographs on the CD-ROM Mr. Bozanic kindly sent us certainly prove his skills at building high-end audio equipment. The photograph reproduced here shows his version of the Prelude stereo preamp, a classic we published decades ago.

Stealing current Dear Editor, I am constructing the project 'Burglar Alarm' published in the January 2004 issue of Elektor. I have a few doubts about the power supply section. Apparently you have not provided over-charge protection for the 12-V SLA battery. Will this not reduce battery life or destroy it due to over charging? Also, the battery charge current limiting resistor used is 1 k (R1) and the series diode (D6) adds around 500 ohms to it. Will this combination provide enough current for efficient charging? I would like to use a 12 V/7 Ah SLA battery.

Kinjal (by email)

With lead-acid batteries (which includes sealed SLAs), charging

with a certain maximum voltage such as 13.2 V or even 13.8 V also serves as an effective over-charge protection. Regarding the charge current, this is intended for continuous charging. There's nothing wrong with the current of about 0.3 mA used in this case (battery capacity 1.2 Ah) as the circuit is continuously connected to the mains. In your case, you intend to use a much larger battery and the current may be increased by changing the 1-kΩ resistor into 680 Ω. Do not use lower values as that may cause R1 to burn out.

Contact those CPLDs

Dear Jan, your 'Hands-On CPLDs' project is supported by a beautiful double-sided board. Unfortunately, the length of the PLCC socket pins and DIP switch pins is such that they can not be soldered at both sides of the board although it is clear that signals have to be routed to a number of these pins. Do you have a solution to this problem or am I barking up the wrong tree?

Philip Hyams

Double-sided boards supplied through our Readers Services are through-contacted unless otherwise stated. You need to solder at the underside of the board only. The through contact will then establish an electrical connection to any tracks that may run at the component side.

Exotic opamp Dear Editor, I'd like to build the Audio Level Check for Line Input project published in the November 2002 issue as I find that signals from my stereo system are causing overdriven recordings.

Unfortunately the TS924IN is unavailable locally, can I use a TL074 instead?

Bernard Hook (by email)

Because of the minimum supply voltage it is not possible to use a 'regular' opamp of the type you suggest. If you need to find an alternative, go for a 'rail to rail' opamp.

CORRECTIONS & UPDATES

MIDI Lights & Slide Control

March 2001, p. 26-33, 000179-1.

A few readers have reported lamp flicker when the control is operated. No problems are observed with constant brightness. Flicker may be suppressed by lengthening the synchronisation pulse. This is easiest done by increasing the value of C1 and C2 to 3.3 nF.

MailBox Terms

- Publication of reader's correspondence is at the discretion of the Editor.
- Viewpoints expressed by correspondents are not necessarily those of the Editor or Publisher.
- Correspondence may be translated or edited for length, clarity and style.
- When replying to Mailbox correspondence, please quote Issue number.
- Please send your MailBox correspondence to:

editor@elektor-electronics.co.uk or Elektor Electronics, The Editor, P.O. Box 190, Tunbridge Wells TN5 7WY, England.

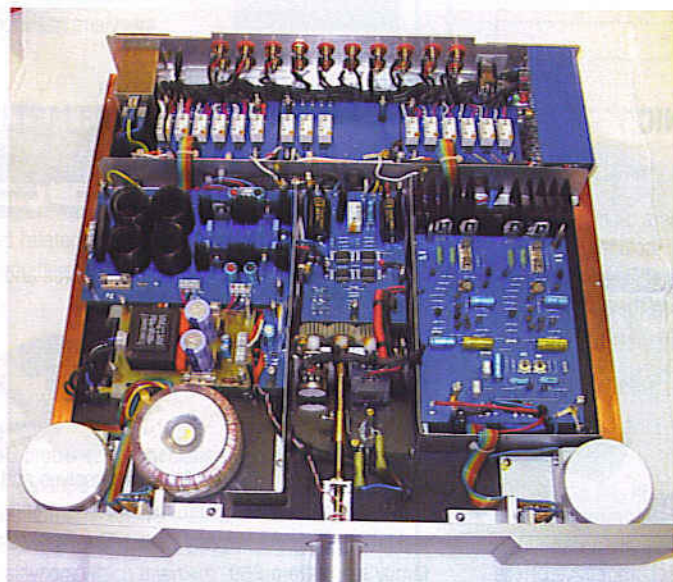

To book your website space contact **Bernard Hubbard**

Tel 00 44 (0)1242 510760 Fax: 0044 (0)1242 226626

ALLGOOD TECHNOLOGY

www.allgoodtechnology.com

Low-medium volume sub-contract assembly. SMT specialist since 1990. Customers include military, aerospace etc. 0402 to BGA capabilities, automatic assembly and hand built prototypes.

BETA LAYOUT

www.pcb-pool.com

Beta layout Ltd Award-winning site in both English and German offers prototype PCBs at a fraction of the cost of the usual manufacturers' prices.



BURN TECHNOLOGY LTD

<http://www.burntec.com>

Distributors of a wide range of device programmers, package adaptors, test and soldering equipment. Order online and get free delivery on all orders over £30.00.

COMPUCUT

<http://www.compucutters.com>

Computer Numerical Control from your home PC. Great for tricky jobs, and accurate repetitive work. We supply: - Software - Interface - Manual - Support
Price £250 plus postage.

CONFORD ELECTRONICS

<http://www.confordelec.co.uk>

Lightweight portable battery/mains audio units offering the highest technical performance. Microphone, Phantom Power and Headphone Amplifiers. Balanced/unbalanced signal lines with extensive RFI protection.

DANBURY ELECTRONICS

<http://www.mc-h.demon.co.uk/transformers.html>

Here you will find our mains and output transformers in Mike Holme's range of valve/tube amplifiers (PP & SE). Also circuits, parts lists, chassis, advice.

DEBUG INNOVATIONS UK

<http://www.debuginnovations.com>

Introducing hassle free prototyping

- RF / Analogue
- High speed digital
- Surface mount
- 0.1" grid
- Power planes
- Unique patch architecture



Forget custom PCBs, start your project now!

EASYSYNC

<http://www.easysync.co.uk>

EasySync Ltd sells a wide range of single and multi-port USB to RS232/RS422 and RS485 converters at competitive prices.



ELEXOL PTY LTD

<http://www.elexol.com>

Developer and manufacturer of

- USB Development Modules.
 - USBMOD Series.
 - USBIO24 Digital Input/Output Module.
 - MP3 Solutions.
 - MP3MOD4 Module.
- Distributor inquiries welcome.



ELNEC

www.elnec.com

- device programmer manufacturer
- selling through contracted distributors all over the world
- universal and dedicated device programmers
- excellent support and after sale support
- free SW updates
- once a months new SW release
- reliable HW
- three years warranty for most programmers



ERVAN INTERNATIONAL CO.

<http://www.ervan-int.com>

Power Electronics and Solar Energy Design and Consultants. Also offers; Discount prices of:

- Ultra Bright LEDs
- PCB LED Cluster Kits
- Laser Pointers
- Solar Modules
- Batteries

FOREST ELECTRONIC DEVELOPMENT

<http://www.fored.co.uk>

FED supply PIC programmers, Basic modules, and development software including a PIC C Compiler, Prog 'n Drop Visual Development and a well featured debugging environment.

FUTURLEC

<http://www.futurlec.com>

Save up to 60% on

- Electronic Components
- Microcontrollers, PIC, Atmel
- Development Boards, Programmers

Huge range of products available on-line for immediate delivery, at very competitive prices.



FUTURE TECHNOLOGY DEVICES

<http://www.ftdichip.com>

FTDI designs and sells USB-UART and USB-FIFO interface i.c.'s.

Complete with PC drivers, these devices simplify the task of designing or upgrading peripherals to USB



HAMMOND ELECTRONICS

<http://www.hammondmfg.com>,

sales@hammond-electronics.co.uk

tel: 01256 812812.

Small die-cast, plastic and metal enclosures for the hobbyist and professional. Widely available from major distributors.



LONDON ELECTRONICS COLLEGE

<http://www.lec.org.uk>

Vocational training and education for national qualifications in Electronics Engineering and Information Technology (BTEC First National, Higher National NVQs, GCSEs and Advanced Qualifications). Also Technical Management and Languages.

MQP ELECTRONICS

<http://www.mqpelectronics.co.uk>

Leaders in Device Programming Solutions.

- Online shop
- Low Cost Adapters for all Programmers
- Single Site and Gang Programmers
- Support for virtually any Programmable Device



NEW WAVE CONCEPTS

<http://www.new-wave-concepts.com>

Software for hobbyists:

- Livewire circuit simulation software, only £29.36
- PCB Wizard circuit design software, only £29.36

Available from all Maplin Electronics stores and www.maplin.co.uk



PEAK ELECTRONIC DESIGN LIMITED

www.peakelec.co.uk

Cool component test gear for your passives and semis. Instant identification, measurement and validation. Connect anyway round. The Peak Atlas family starts from £59.



QUASAR ELECTRONICS

www.QuasarElectronics.com

Over 300 electronic kits, projects and ready built units for hobby, education and industrial applications including PIC/ATMEL programming solutions. Online ordering facilities. Tel: +44 (0) 870 246 1826 Fax: +44 (0) 870 460 1045 Email: sales@QuasarElectronics.com



ROBOT ELECTRONICS

<http://www.robot-electronics.co.uk>

- Ultrasonic rangefinders
- Motor H-Bridge controllers
- Magnetic Compasses
- RC servos and controllers
- PIC programmers and components
- Electronic Design/Development and Manufacturer to industry



TECHNOBOTS

<http://www.technobots.co.uk>

Welcome to Technobots - the one stop shop specially for the remote operated robot builder, radio control and engineering hobbyist.



TELNET

<http://www.telnet.uk.com>

The site shows graphically Telnets wide range of quality second-user test and measurement equipment, including oscilloscopes and spectrum analysers.



ULTRALEDs

<http://www.ultraleds.co.uk>

tel: 0871 7110413 Large range of low cost Ultra bright leds and Led related lighting products. Major credit cards taken online with same day despatch.

USB INSTRUMENTS

<http://www.usb-instruments.com>

USB Instruments specialises in PC based instrumentation products and software such as Oscilloscopes, Data Loggers, Logic Analysers which interface to your PC via USB.



VIEWCOM

<http://www.viewcom.f9.co.uk>

tel: 020 8471 9338 fax: 020 8552 0946

- Mail Order supplier of:
- Integrated Circuits and Components.
- Kit and parts for Elektor projects.
- Transistors, FETs, Capacitors, Resistors, Crystals, etc and hard to find devices.

Viewcom Electronics, 77 Upperton Road West, Plaistow, London E13 9LT

WTECK

www.component-technology.co.uk

Kits/modules for students /hobbyists. PIC microcontroller 18F45X, 16F87X ProtoBoards for ease and fast development. CCTV infrared Illuminators. 5% discount code 'eenlink2004' for Elektor Readers.



PROMOTE YOUR WEBSITE HERE

Elektor Electronics have a feature to help customers to promote their websites, Net Links - a permanent feature of the magazine where you will be able to highlight your site on a regular basis.

- For just £120 + VAT (£10.90 per issue for eleven issues) Elektor will publish your company name, a 25-word description and your website address.
- For £300 + VAT for the year (£27.27 per issue for eleven issues) we will publish the above plus run a 3cm deep full colour screen shot from your site.

Places are limited and spaces will go on a strictly first come, first served basis, please fax back your order today!

I wish to promote my company, please book my space:

- Text insertion only for £120 + VAT
- Text and photo for £300 + VAT

NAME: ORGANISATION:

JOB TITLE:

ADDRESS:

..... TEL:

PLEASE COMPLETE COUPON BELOW AND FAX BACK TO 00-44-(0)1242 226626

COMPANY NAME

WEB ADDRESS

25-WORD DESCRIPTION

.....

.....

.....

.....

.....

.....

ELECTRONIC ENTHUSIASTS

Only one magazine tests its projects and circuits in its own lab before publication -

ELEKTOR ELECTRONICS
THE ELECTRONICS & COMPUTER MAGAZINE

SUBSCRIBE TODAY!

Contact: Worldwide Subscription Service Ltd,
Unit 4 Gibbs Reed Farm, Pashley Road, Ticehurst
TN5 7HE Telephone: (+44) (0) 1580 200657
Fax: (+44) (0) 1580 200616 Or visit our Website:
www.elektor-electronics.co.uk

Danbury Electronics

U.K. Manufacturers & designers of quality Transformers for over 20 years.

- IVA-750VA size range, medium quantities
- Mains, Audio, Loudspeaker & ferrite types
- Specialise in Valve/Tube mains and output transformers.
- Rewind/Replacement of rare/special transformers
- A standard range of Valve/Tube Amp mains & Output Tx's (P/P, SE etc) is available through Mike Holme's web site: www.mc-h.demon.co.uk/transformers.html (Also, Valve circuits, Parts lists, Chassis & Advice)
- Established supplier to Maplin Electronics (www.maplin.co.uk) for over 15 years.

Contact **David Brooks I.Eng MIEE (Proprietor)**

Phone : 01245 328174

Fax: (24Hr) 01245 328963

Email: DanburyElectX@aol.com

20 Cutlers Rd, Saltcoats Ind. Estate,
South Woodham Ferrers, Essex. CM3 5XJ (UK)



**elektor
electronics**

New

Item Tracer

1985 - 2003

EIT contains the digital contents list of all articles published in the magazine over the period 1985-2003. The EIT is supplied on a 3.5-inch diskette, runs under Windows and offers an attractive graphics interface. The program allows searching for various keywords or combinations.



£ 8.25 (US\$9.50)

Computer requirements:
PC386/486/pentium
4 MB RAM
at least Windows 3.1
2 MB free space on disk

Order now using
the Order Form
in the Readers
Services section
in this issue

See also www.elektor-electronics.co.uk



**elektor
electronics**

RRP £16.25
(US\$28.75)

New CD elektor 2003

Volume 2003 on CD-ROM

The Elektor 2003 CD-ROM contains all articles, with the exception of news columns, published in volume 2003. Using the supplied Acrobat Reader program, articles are presented in the same page layout as the magazine originals.

Additional features:

- print pcb layouts with up to 600 dpi resolution;
- adapt pcb layouts with a drawing program;
- quickly find articles, components, subjects, and so on, from monthly contents lists, the year index (on subject basis), or on the basis of titles, words, and components;
- transfer diagrams, illustrations, pcb layouts and text to other programs.
- HTML overview for MacOS and Linux users



NEW! DiskMirror to run multiple year volumes from hard disk

Order now using the Order Form
in the Readers Services section
in this issue.

Elektor Electronics (Publishing) P.O. Box 190
Tunbridge Wells TN5 7WY England
Telephone +44 (0) 1580 200 657

Fax +44 (0) 1580 200 616

See also
www.elektor-electronics.co.uk

Please Note

Software items marked @ are available from the Free Downloads page of the Publishers' website at www.elektor-electronics.co.uk.
Diskettes are supplied for the convenience of readers without Internet access.

EVERGREENS

	£	US \$
Elektor Electronics Help Disk		
966022-1 Disk, Windows version	8-15	14.45
Elektor Electronics Item Tracer 1985-2003		
046003-11 contents database (disk, Windows version)	8-15	14.35
Universal Prototyping Boards		
UPBS-1 PCB	2-45	4.30
UPBS-2 2 PCBs	4-10	7.25
UPBS-4 4 PCBs	6-55	11.55

no.333 JUNE 2004

Multimedia Programmer		
@ 020336-1 PCB	8-80	15.60
@ 020336-11 Disk, firmware & source code	4-90	8.65
Pocket Pong		
@ 030320-11 Disk, PIC software	4-90	8.65
Rail Router		
@ 030403-1 PCB	10-80	19.15
@ 030403-11 Disk, PIC & PC software	4-90	8.65
@ 030403-41 PIC16F877-20/P, programmed	21-45	37.95
Smooth Operator		
@ 030209-11 Disk, PIC software	4-90	8.65
@ 030209-41 PIC16F84-10/P, programmed	14-70	26.00

no.332 MAY 2004

Design Your Own IC		
@ 030385-1 PCB	15-65	27.70
High-End Preamp		
@ 020046-1 PCB — main board	8-45	14.95
@ 020046-2 PCB — relay board	7-50	13.30
@ 020046-3 PCB — PSU board	6-70	11.85
@ 020046-11 Disk	4-90	8.65
@ 020046-41 PIC18LF452-VL, programmed	28-20	49.90
Wind Speed & Direction Meter		
@ 030371-11 Disk, project software	4-90	8.65
@ 030371-41 PIC16F871, programmed	17-55	31.05

no. 331 APRIL 2004

Drop-in Microcontroller Board		
@ 020148-1 PCB	8-60	15.20
@ 020148-11 Disk, sample project file	4-90	8.65
Pandora's Sound & Music Box		
@ 030402-1 PCB	10-60	18.75
@ 030402-11 Disk, source and hex code files	4-90	8.65
@ 030402-41 PIC16F871/P, programmed	20-55	36.40
VHF-Low Explorer		
@ 020416-1 PCB	8-80	15.50

No. 330 MARCH 2004

Build Your Own DRM Receiver		
@ 030365-1 PCB	9-10	16.10
@ 030365-11 Disk, DRM.exe program	4-90	8.65
Code Lock		
@ 020434-1 PCB	9-60	16.95
@ 020434-11 Disk, source & hex code files	4-90	8.65
@ 020434-41 PIC16F84A-4/P, programmed	14-70	26.00
Hands-on CPLDs (2)		
@ 030052-1 PCB	8-90	15.75
@ 030052-11 Software	4-90	8.65
@ 030052-41 EPM7128SLC84-15, programmed	33-40	59.10
Multichannel Failsafe for Radio Controlled Models		
@ 020382-11 Disk, source code file	4-90	8.65
@ 020382-41 AT89C52-24/JL, programmed	6-70	15.40
Multifunction Frequency Meter		
@ 030136-1 PCB	9-35	16.55
@ 030136-11 Disk, project software	4-90	8.65
@ 030136-41 AT90S2313-10/PC, programmed	7-95	14.05

No. 329 FEBRUARY 2004

Digital Alarm Clock		
@ 030096-11 Disk, PIC source and hex code	4-90	8.65
@ 030096-41 PIC16F84-04/p, programmed	15-20	26.90
iAccess		
@ 020163-11 Disk set, source code and control software	7-50	13.30
@ 020163-41 AT89S8252-12PC, programmed	13-90	24.60
Simple 12-to-230V Power Inverter		
@ 020435-1 PCB	8-50	15.05
Touch-controlled Switch		
@ 030214-11 Disk, PIC source code	4-90	8.65
@ 030214-41 PIC12C508A04/S08, programmed	6-15	10.90

No. 328 JANUARY 2004

64-K 80C552 Flash Board		
--------------------------------	--	--

GENERAL

Printed-circuit boards (PCBs), self-adhesive front panel foils, ROMs, EPROMs, PALs, GALs, microcontrollers and diskettes for projects which have appeared in Elektor Electronics may be ordered using the Order Form printed opposite. The form may also be used to order books (private customers only).

= The artwork for making a PCB which is not available ready-made through the Readers Services may be found in the relevant article.

= EPROMs, GALs, PALs, (E)PLDs, MACHs, PICs and other microcontrollers are supplied ready-programmed.

Prices and item descriptions subject to change. The publishers reserve the right to change prices without prior notification. Prices and item descriptions shown here supersede those in previous issues. E & OE

PAST ISSUES

Past issues, if available, should be ordered from Worldwide Subscription Service Ltd, Unit 4, Gibbs Reed Farm, Pashley Road, TICEHURST TN5 7HE, England, telephone (+44) 1580 200657, fax (+44) 1580 200616, email wwss@wwss.demon.co.uk

Prices of past issues (except July/August and December), including postage for single copies, are £4.75 (UK and Eire); £5.30 (air mail Europe); £6.10 (airmail outside Europe). Prices of past July/August and December issues, including postage for single copies, are £6.65 (UK and Eire); £7.35 (airmail Europe); and £8.45 (airmail outside Europe).

PAST ARTICLES

For information on past articles, please contact our Editorial and Administrative Offices, telephone (01580) 200657; fax 200616, email sales@elektor-electronics.co.uk

	£	US \$
@ 030042-1 PCB	9-35	16.55
@ 030042-11 Disk, misc. project software	4-90	8.65
@ 030042-21 29F010, programmed	10-00	17.70
@ 030042-31 GAL 16V8D150R, programmed	6-10	10.80
Climate Logger		
@ 030076-1 PCB	7-75	13.70
@ 030076-11 Disk, Windows software	4-90	8.65
FMS Flight Simulator Encoder		
@ 030066-1 PCB	10-20	18.05
@ 030066-41 87LPC767BN, programmed	17-05	30.15
LED Roulette		
@ 030168-1 PCB	17-90	31.60
@ 030168-11 Disk, source and hex files	4-90	8.65
@ 030168-41 89C2051-12PC, programmed	8-05	14.25
Multi-event Alarm Clock		
@ 020304-11 Disk, C (source) hex files	4-90	8.65
@ 020304-41 AT89C2051-12PC, programmed	6-10	10.80
Stepper Motors Uncovered		
@ 020127-41 PIC16F873-20/SP	19-10	33.80
No. 327 DECEMBER 2003		
FM Remote Control Transmitter & Receiver		
@ 034044-1 PCB	10-20	18.05
LED Christmas Decoration		
@ 030157-1 PCB	7-55	13.35
P87LPC76x Programmer		
@ 030313-11 Disk, project software	4-90	8.65
Project Timekeeper		
@ 020350-11 Disk, source & object code files	4-90	8.65
@ 020350-41 PIC16F84-10/P, programmed	13-15	23.25
Stepper Motors Uncovered (2)		
@ 020127-11 Disk, source code file	4-90	8.65
Universal Clock Generator		
@ 020395-11 Disk, source code file	4-90	8.65
Wireless RS232 Link		
@ 030204-1 PCB	8-70	15.40
No. 326 NOVEMBER 2003		
Precision Measurement Central		
@ 030060-4 PCB	8-70	15.40
No. 326 NOVEMBER 2003		
Rev Counter for R/C Models		
@ 024111-1 PCB	17-50	31.00
@ 024111-11 Disk, source and hex code	4-90	8.65
@ 024111-41 89C2051-12PC, programmed	8-85	15.65
Running Text Display		
@ 020407-11 Disk, source and hex code	4-90	8.65
USB Analogue Converter		
@ 020374-1 PCB	7-65	13.50
@ 020374-11 Disk, hex code and Windows software	4-90	8.65
@ 020374-41 PIC16C765, programmed	13-25	23.45
No. 325 OCTOBER 2003		
DDS RF Signal Generator		
@ 020299-1 PCB, generator	11-60	20.55
@ 020299-2 PCB, control/supply	12-10	21.45
@ 020299-41 AT90S8515 8PC, programmed	30-55	54.05
Minimalist Induction-Balance Metal Detector		
@ 020290-1 PCB	8-95	15.85
Xilinx PROM Programmer		
@ 010109-11 Software	4-90	8.65
No. 324 SEPTEMBER 2003		
ATV Picture Generator		
@ 020295-11 Disk, source & hex code files	4-90	8.65
@ 020295-41 AT90S8515-8PC, programmed	15-20	26.90

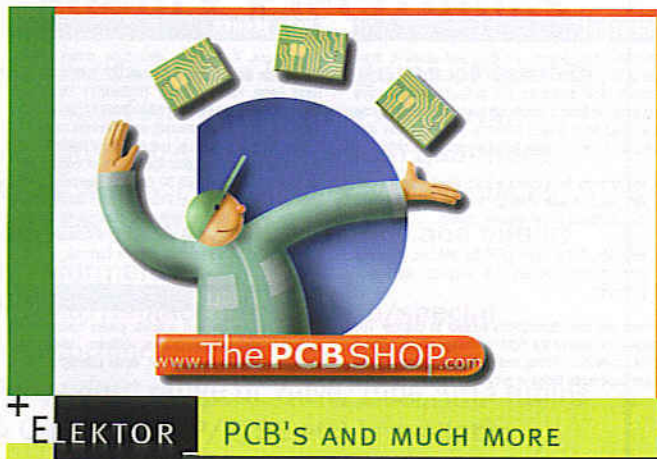

	£	US \$
020295-42 AT90S1200-12PC, programmed	13-90	24.60
DTMF Remote Telephone Switch		
@ 020294-1 PCB	11-65	20.60
@ 020294-11 Disk, project software	4-90	8.65
020294-41 PIC16F84A-20/P, programmed	14-70	26.00
LC Display with I²C Bus		
@ 030060-2 PCB	7-35	13.00
PICProg 2003		
@ 010202-1 PCB	9-05	16.00
@ 010202-11 Disk, Windows software	4-90	8.65
010202-41 PIC16F874-20/P, programmed	23-55	41.65
Polyphonic Doorbell		
@ 020354-11 Disk, project software	4-90	8.65
020354-41 PIC16F84A-10/P, programmed	14-45	25.55
Precision Measurement Central		
030060-91 Ready-assembled & tested board	69-00	112.50
Valve Preamp (1)		
@ 020383-1 PCB, amplifier board	11-55	20.40
@ 020383-2 PCB, power supply board	11-40	20.20
@ 020383-3 PCB, I/O board	10-10	17.80
No. 323 JULY/AUGUST 2003		
Add a Sparkle		
@ 020293-11 Disk, HEX and source files	4-90	8.65
020293-41 PIC12C509A-04/SM, programmed	7-40	13.10
AT90S2313 Programmer		
@ 034036-1 PCB	9-05	16.00
Hard Disk Selector		
@ 034050-1 PCB	9-45	16.75
Mini Running Text Display		
@ 020365-11 Disk, source code file	4-90	8.65
Mini Test Chart Generator		
@ 020403-11 Disk, PIC source code	4-90	8.65
Programming Tool for ATtiny15		
@ 030030-1 PCB	7-55	13.35
@ 030030-11 Disk, project software	4-90	8.65
Quad Bridge Car Amp		
@ 034039-1 PCB	8-70	15.35
Remote Light Control with Dimmer		
@ 020337-11 Disk, HEX and source files	4-90	8.65
020337-41 AT89C2051-12, programmed	6-25	11.05
No. 322 JUNE 2003		
AVR TV Tennis		
@ 030026-1 Main PCB	8-70	15.40
@ 030026-2 Pushbutton PCB	8-60	15.25
@ 030026-11 Disk, AVR source code	4-90	8.65
030026-41 AT908515, programmed	15-20	26.90
Electronic Knotted Handkerchief		
@ 020308-11 Disk, PC and controller software	4-90	8.65
020308-41 AT90S2313-10PC, programmed	12-60	22.30
Low-Cost LCD Controller (2)		
@ 020114-1 PCB	8-70	15.35
@ 020114-11 Disk, project software	4-90	8.65
Night Light Control		
@ 020115-11 Disk, hex and source code	4-90	8.65
020115-41 AT90S2313-10PC, programmed	12-85	22.75
Universal XA Development Board		
@ 010103-1 PCB	13-20	23.35
@ 010103-11 Disk, GAL code, EPROM hex files, XADEV	4-90	8.65
010103-21 EPROM IC8, 27C256-90, programmed	10-00	17.70
010103-22 EPROM IC9, 27C256-90, programmed	10-00	17.70
010103-31 GAL 16V8, programmed	4-80	8.50

	£	US \$
No. 321 MAY 2003		
Countdown Timer		
@ 020296-11 Disk, source and hex code	4-90	8.65
020296-41 AT90S1200, programmed	13-90	24.60
USB Audio Recorder		
@ 012013-11 Disk, EPROM hex code	4-90	8.65
012013-21 EPROM 27C512, programmed	12-60	22.30
Valve Final Amp (2)		
@ 020071-1 Amplifier board (one channel)	15-10	26.75
@ 020071-2 Power supply board	10-05	17.75
No. 320 APRIL 2003		
8-Channel Disco Light Controller		
@ 010131-1 PCB	13-10	23.15
010131-41 87C750 or 87C71, programmed	23-00	40.70
Pico PLC		
@ 010059-1 PCB	18-70	33.10
@ 010059-11 Disk, test program	4-90	8.65
Single-Chip Tone Control		
@ 020054-4 PCB	10-90	19.30
Switched-Outlet Power Bar with RS232 Control		
@ 020298-1 PCB	10-80	19.10
@ 020298-11 Disk, project software	4-90	8.65
Temperature Indicator for the PC		
@ 020380-11 Disk, source and compiled code	4-90	8.65
020380-41 AT89C2051, programmed	10-25	18.15
No. 319 MARCH 2003		
17 V / 10 A Switch-Mode Power Supply		
@ 020054-3 PCB	9-45	16.65
Add-on Switch unit for R/C Models		
@ 020126-1 PCB	8-95	15.85
@ 020126-11 Disk, hex and source files	4-90	8.65
020126-41 PIC16C712-041/S0, programmed	15-20	26.90
AVR Development System		
@ 020351-1 PCB	13-20	23.35
@ 020351-11 Disk, example programs	4-90	8.65
Guitar Effects Switchbox		
@ 020181-1 PCB	13-15	23.30
Intelligent Fan Timer		
@ 020170-11 Disk, project software	4-90	8.65
020170-41 MSP430F1121, programmed	11-30	20.00
SAA3049 Replacement		
@ 020085-1 PCB	13-05	23.10
@ 020085-11 Disk, source and hex code	4-90	8.65
020085-41 87LPC764BN, programmed	9-90	17.55
Two-Colour Running Light		
@ 010134-1 PCB, controller board	8-25	14.60
@ 010134-2 PCB, LED board	10-65	18.80
@ 010134-11 Disk, project software	4-90	8.65
010134-41 AT89C2051-12PC, programmed	7-15	12.65
No. 318 FEBRUARY 2003		
20/40 MHz Logic Analyser		
@ 020032-1 PCB	15-20	26.85
@ 020032-11 Disk, demo program	4-90	8.65
020032-41 AT90S8515-8PC, programmed	15-10	26.70
Active Loudspeaker System (2)		
@ 020054-2 PCB	7-95	14.05
Autoranging Capacitance Meter		
@ 020144-1 PCB	7-35	13.00
@ 020144-11 Disk, source and hex files	4-90	8.65
020144-41 PIC16F84A-20/P, programmed	15-20	26.90
Dimmer with 0-10 V Control Input		
@ 010125-1 control PCB	9-60	17.00
@ 010125-2 dimmer PCB	8-95	15.85
Electronic Hourglass		
@ 020036-1 PCB	18-55	32.85
@ 020036-11 Disk, project software	4-90	8.65
020036-41 PIC16F84-04/P, programmed	15-20	26.90
Optimise your PC Soundcard		
@ 020184-11 Disk, Excel spreadsheet	4-90	8.65
No. 317 JANUARY 2003		
Active Loudspeaker System (1)		
@ 020054-1 PCB	6-90	12.20
Electronic RPG Dice Roller		
@ 020005-1 PCB	10-05	17.75
@ 020005-11 Disk, source code file	4-90	8.65
020005-41 AT90S4433-8PC, programmed	30-80	54.50
Rodent Deterrent		
@ 020110-1 PCB	12-05	21.30
SMS-Controlled Mains Sockets		
@ 020157-1 PCB	12-90	22.85

Products for older projects (if available) may be found on our web site <http://www.elektor-electronics.co.uk>

ORDERING INSTRUCTIONS, P&P CHARGES

Except in the USA and Canada, all orders, except for subscriptions (for which see below), must be sent BY POST or FAX to our Tunbridge Wells address using the Order Form overleaf. On-line ordering: <http://www.elektor-electronics.co.uk>

Readers in the USA and Canada may (but are not obliged to) send orders, except for subscriptions (for which see below), to the USA address given on the order form. Please apply to Old Colony Sound for applicable P&P charges. Please allow 4-6 weeks for delivery.

Orders placed on our Tunbridge Wells office must include P&P charges (Priority or Standard) as follows:

UK: £3.50 Europe: £5.00 (Standard) or £7.00 (Priority) Outside Europe: £8.00 (Standard) or £12.00 (Priority)

HOW TO PAY

Unless you have an approved credit account with us, all orders must be accompanied by the full payment, including postage and packing charges as stated above. Payment may be made by cheque drawn on a London clearing bank (but see para. 4 below), postal order, VISA, Access, MasterCard or EuroCard (when paying by credit card, the order must go the cardholder's address). Do not send cash through the mail. Cheques and postal orders should be crossed and made payable to 'Elektor Electronics (Publishing)'. Payment may also be made by direct transfer from a private or business Giro account to our **Giro account No. 34 152 3801** by completing and sending to the National Giro Centre, in a National Giro postage paid envelope, a National Giro transfer/deposit form. Do not send Giro transfers direct to us, as this will delay your order. If you live outside the UK, payment may also be made by Bankers' sterling draft drawn on a London clearing bank, Eurocheque made out in pounds sterling (with holder's guarantee card number written on the back), or US or Canadian dollar cheque drawn on a US or Canadian bank. If you pay by Bankers' sterling draft, make clear to the issuing bank that your full name and address MUST be communicated to the London clearing bank. Our bankers are **NAT WEST PLC, 1 St James's Square, Wadhurst, East Sussex TN5 6BH, England. Our account number is 3512 5225, Sorting Code 60-22-15. IBAN code: GB40 NWB K6 022 15 3512 5225 BIC code: NWB KGB 2L**

COMPONENTS

Components for projects appearing in Elektor Electronics are usually available from certain advertisers in this magazine. If difficulties in the supply of components are envisaged, a source will normally be advised in the article. Note, however, that the source(s) given is (are) not exclusive.

TERMS OF BUSINESS

Delivery Although every effort will be made to dispatch your order within 2-3 weeks from receipt of your instructions, we can not guarantee this time scale for all orders. **Returns** Faulty goods or goods sent in error may be returned for replacement or refund, but not before obtaining our consent. All goods returned should be packed securely in a padded bag or box, enclosing a covering letter stating the dispatch note number. If the goods are returned because of a mistake on our part, we will refund the return postage. **Damaged goods** Claims for damaged goods must be received at our Tunbridge Wells office within 10 days (UK); 14 days (Europe) or 21 days (all other countries). **Cancelled orders** All cancelled orders will be subject to a 10% handling charge with a minimum charge of £5.00. **Patents** Patent protection may exist in respect of circuits, devices, components, and so on, described in our books and magazines. Elektor Electronics (Publishing) does not accept responsibility or liability for failing to identify such patent or other protection. **Copyright** All drawings, photographs, articles, printed circuit boards, programmed integrated circuits, diskettes and software carriers published in our books and magazines (other than in third-party advertisements) are copyright and may not be reproduced or transmitted in any form or by any means, including photocopying and recording, in whole or in part, without the prior permission of Elektor Electronics (Publishing) in writing. Such written permission must also be obtained before any part of these publications is stored in a retrieval system of any nature. Notwithstanding the above, printed-circuit boards may be produced for private and personal use without prior permission. **Limitation of liability** Elektor Electronics (Publishing) shall not be liable in contract, tort, or otherwise, for any loss or damage suffered by the purchaser whatsoever or howsoever arising out of, or in connexion with, the supply of goods or services by Elektor Electronics (Publishing) other than to supply goods as described or, at the option of Elektor Electronics (Publishing), to refund the purchaser any money paid in respect of the goods. **Law** Any question relating to the supply of goods and services by Elektor Electronics (Publishing) shall be determined in all respects by the laws of England.

January 2004

SUBSCRIPTION RATES

FROM JANUARY 2004 ISSUE

	Standard	Plus
United Kingdom	£39.50	£45.50
Economy Mail		
Rest of the World (excluding Europe)	£51.30	£57.30
Priority Airmail		
Europe & Eire	£52.50	£58.50
Middle East, Africa, Southwest Asia, Central & South America	£64.00	£70.00
Australia, New Zealand, Far East & Pacific Territories	£66.00	£72.00
Airfreight		
USA & Canada only	US\$88.00	US\$96.50

Payment should be made by:

- Cheque or bankers' draft in sterling drawn on a London clearing bank (except in the USA and Canada — see below);
- US\$ cheques drawn on a US or Canadian bank — only by subscribers in the USA or Canada.
- Direct transfer to our bank (NAT WEST PLC, 1 St James's Square, Wadhurst, East Sussex TN5 6BH, England). Our account number is 3512 5225, Sorting Code 60-22-15. IBAN code: GB40 NWB K6 022 15 3512 5225 BIC code: NWB KGB 2L
- Postal order.
- Credit card: VISA, ACCESS, Euro/MasterCard, JCB Electron or Switch.
- Transfer to our Giro Account number 34 152 3801. Giro transfers should be made by completing and sending the appropriate transfer/deposit form to the National Giro Centre (UK) or to your national Giro Centre.

Cheques and postal orders should be made payable to Elektor Electronics (Publishing). Do not send cash through the mail.

SUBSCRIPTION CONDITIONS

The standard subscription order period is twelve months.

If a permanent change of address during the subscription period means that copies have to be despatched by a more expensive service, no extra charge will be made. Conversely, no refund will be made, nor expiry date extended, if a change of address allows the use of a cheaper service.

Student applications, which qualify for a 20% (twenty per cent) reduction in current rates, must be supported by evidence of studentship signed by the head of the college, school or university faculty. A standard Student Subscription costs £31.60, a Student Subscription-Plus costs £37.60 (UK only).

Please note that new subscriptions take about four weeks from receipt of order to become effective.

Cancelled subscriptions will be subject to a charge of 25% (twenty-five per cent) of the full subscription price or £7.50, whichever is the higher, plus the cost of any issues already dispatched. Subscriptions cannot be cancelled after they have run for six months or more.

January 2004

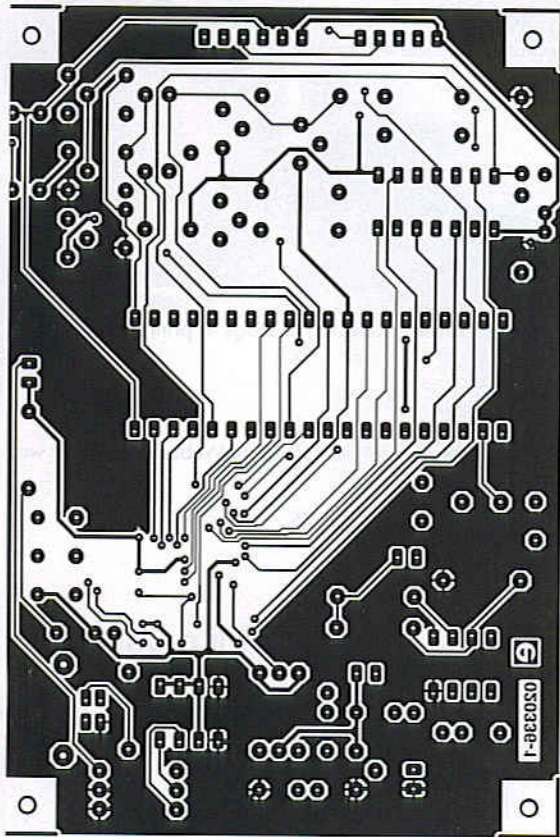

Multi Programmer 020336-1 (solder side)

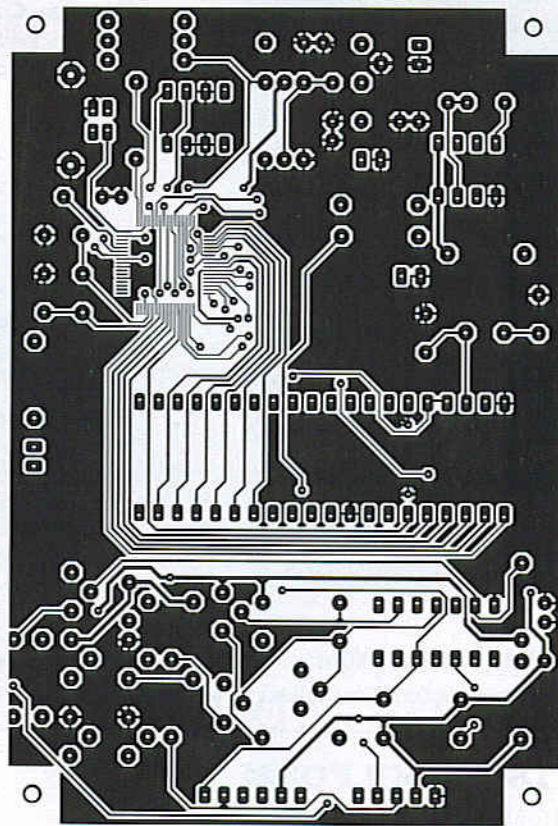

Multi Programmer 020336-1 (components side)

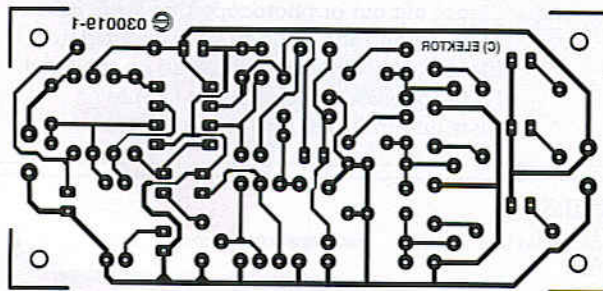

Personal Sound to Light Unit 030019-1

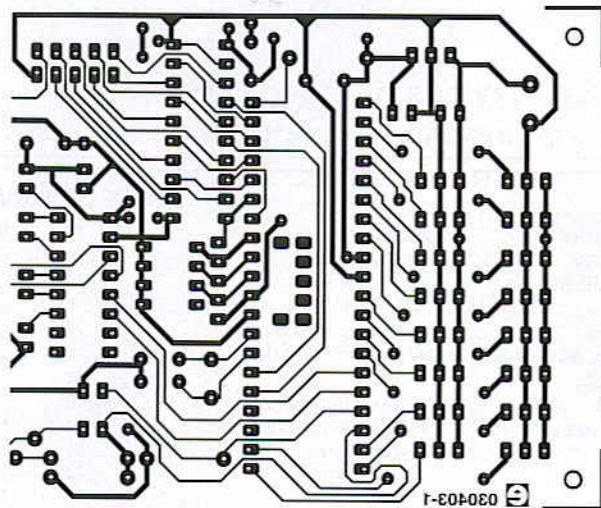

Rail Router 030403-1

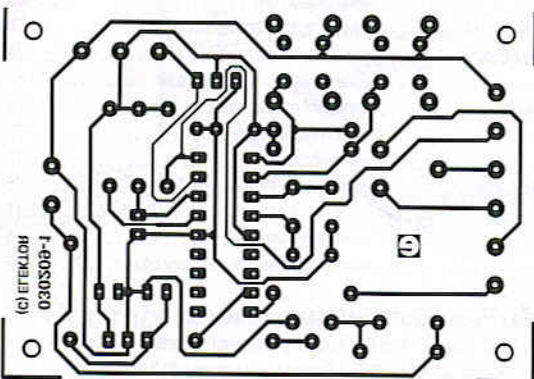

Smooth Operator 030209-1

All PCB layouts shown reflected and at true size (100%) unless otherwise stated.

Mini Webserver for Internet and Intranet

A newly developed add-on interface for our incredibly popular MSC1210 microcontroller board (also known as 'Precision Measurement Central') provides network and Internet connectivity, allowing the processor to publish its own data pages onto the web. As a practical example, the article describes a temperature logger allowing the user to enter, via the Internet, temperature limits and an email alarm address to which a predefined message is sent. Likewise, the Mini Web Server makes it possible for network ports to be switched or interrogated, all from an Internet-connected PC, literally anywhere on the globe.

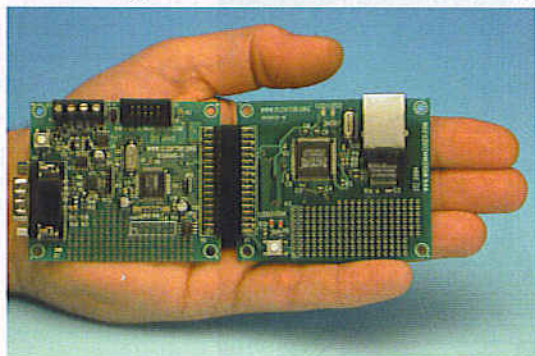

Do not miss the best selling issue of the year. Reserve your copy NOW.

Summer Circuits 2004

The combined July/August 2004 issue will contain a collection of more than 50 short articles covering

- small circuits
- design ideas
- IC presentations
- application notes
- hardware & software tips
- free downloads
- PCB layouts
- junkbox projects

... and that's more than some of our competitors manage to print in four months.

Other regular-size articles

Besides the small circuit collection and our bumper 'Mini Webserver' project we intend to run the following full-size articles:

- TV Commercials Killer
- Working with Active X
- Room Thermometer
- Wireless Control for Canon EOS Cameras

RESERVE YOUR COPY NOW!

UK subscribers will receive the magazine a few days before this date.

The July/August 2004 issue goes on sale on Friday 18 June 2004 (UK distribution only).

Article titles and magazine contents subject to change.

NEWSAGENTS ORDER FORM

SHOP SAVE / HOME DELIVERY

Please save / deliver one copy of *Elektor Electronics* magazine for me each month

Name:
 Address:
 Post code:
 Telephone:
 Date:
 Signature:



**elektor
electronics**

Please cut out or photocopy this form, complete details and hand to your newsagent. *Elektor Electronics* is published on the third Friday of each month, except in July. Distribution S.O.R. by Seymour (NS).

INDEX OF ADVERTISERS

Allgood Technology, Net Links	www.allgoodtechnology.com	74
Beta Layout, Net Links	www.pcb-pool.com	9, 74
Burn Technology LTD, Net Links	www.burntec.com	74
CMS	www.cms.uk.com	9
Compucut, Net Links	www.compucutters.com	74
Conford Electronics, Net Links	www.confordelec.co.uk	74
Cricklewood	41
Danbury, Net Links	www.mc-h.demon.co.uk	74, 76
Debug Innovations, Net Links	www.debuginnovations.com	74
Display Electronics	www.distel.co.uk	31
Easysync, Net Links	www.easysync.co.uk	74
Elexol, Net Links	www.elexol.com	74
Elneec, Net Links	www.elneec.com	74
Ennovi	www.ennovi.co.uk	41
Ervan International, Net Links	www.ervan-int.com	74
Eurocircuits	www.thepcbshop.com	78
Forest, Net Links	www.fored.co.uk	17, 74
Future Technology Devices, Net Links	www.ftdchip.com	74
Futurlec, Net Links	www.futurlec.com	74
Hammond Electronics, Net Links	www.hammondmfg.com	74
ITP	www.itp101.com	9
Labcenter	www.labcenter.co.uk	84
London Electronics College, Net Links	www.lec.org.uk	74
Matrix Multimedia Ltd	www.matrixmultimedia.co.uk	61
Milford Instruments	www.milinst.demon.co.uk	23

MQP Electronics, Net Links	www.mqpelectronics.co.uk	74
Net Links	74, 75
New Wave Concepts, Net Links	www.new-wave-concepts.com	74
Number One Systems	www.numberone.com	41
PAGM	www.pagm.co.uk	2
Peak Electronic, Net Links	www.peakelec.co.uk	74
Pico	www.drdaq.com	83
Quasar Electronics, Net Links	www.quasarelectronics.com	49, 75
Robot Electronics, Net Links	www.robot-electronics.co.uk	75
Stewart of Reading	www.stewart-of-reading.co.uk	61
Technobots, Net Links	www.technobots.co.uk	75
Telnet, Net Links	www.telnet.uk.com	75
Ultraleads, Net Links	www.ultraleads.co.uk	75
USB Instruments, Net Links	www.usb-instruments.com	75
Vero Technology	www.veroll.com	17
Viewcom, Net Links	www.viewcom.f9.co.uk	75
Wteck, Net Links	www.component-technology.co.uk	75

ADVERTISING SPACE for the issue of **17 August 2004** may be reserved not later than **21 July 2004** with Elektor Electronics (Publishing) Advertisement Office - 3 Crescent Terrace - Cheltenham GL50 3PE - England - Telephone 01242 510 760 - Fax 01242 226 626 - e-mail: bernardhubbard@ukonline.co.uk to whom all correspondence, copy instructions and artwork should be addressed.

DrDAQ Data Logger

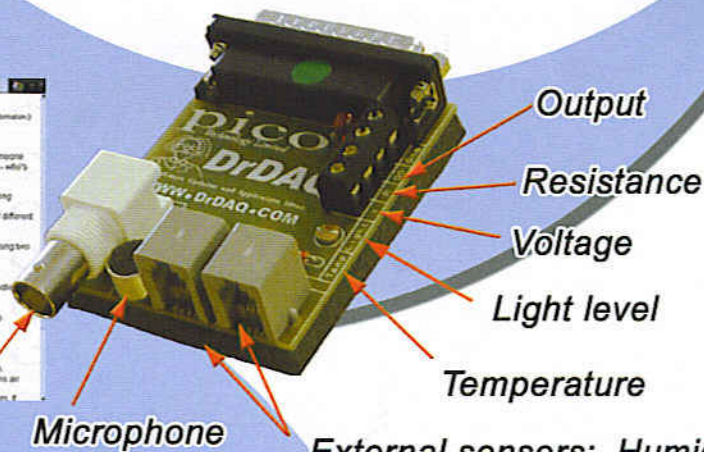
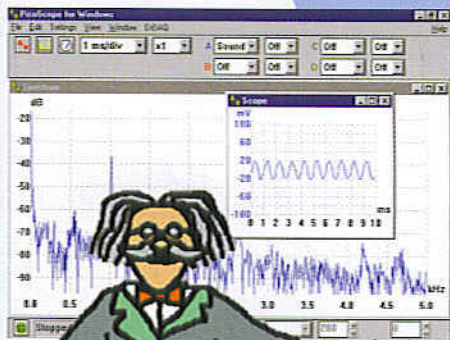

- Low cost - under £60
- Built in sensors for light, temperature and sound (level and waveforms)
- Use DrDAQ to capture fast signals
- Outputs for control experiments
- Supplied with both PicoScope (oscilloscope) and PicoLog (data logging) software

For more information on DrDAQ, please visit:

www.picotech.com/drdaq94

PC Oscilloscopes

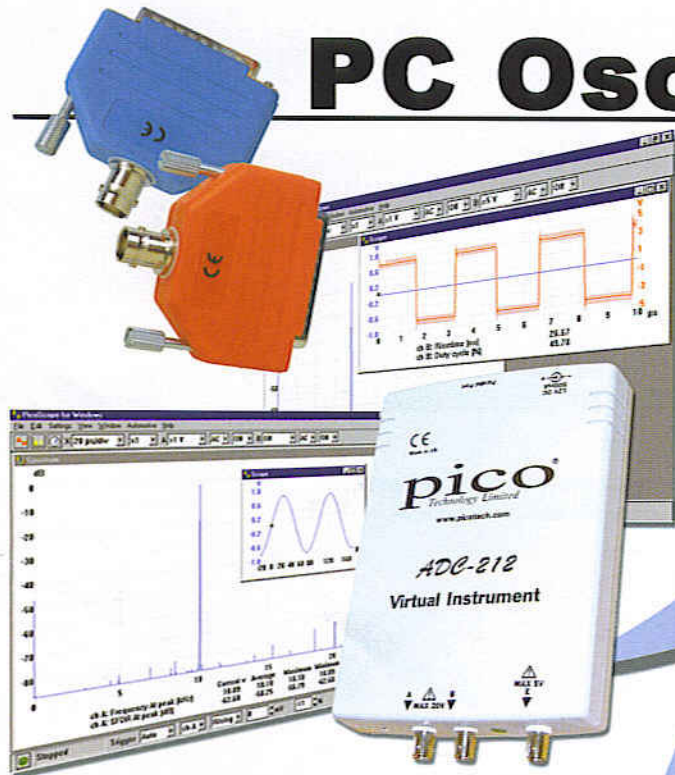

- Scope and spectrum analyser functions
- A fraction of the cost of benchtop scope
- Save multiple setups, for ease of use
- Save, print and e-mail your traces
- FREE technical support for life
- FREE software and upgrades
- Automated measurements

For more information on our scopes, please visit:

www.picotech.com/scope165

Tel: 01480 396395 Fax: 01480 396296 E-mail: sales@picotech.com

PICO
Technology Limited

PROTEUS

The Complete Electronics Design System

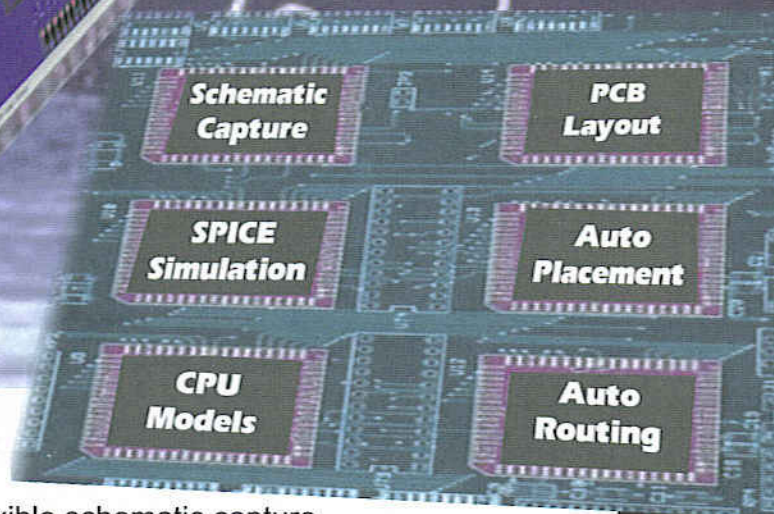
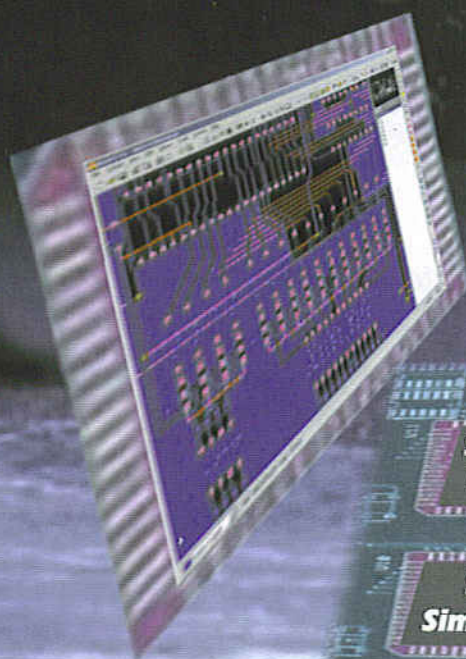

VSM

Virtual System Modelling

Schematic & PCB Layout

- Powerful & flexible schematic capture.
- Auto-component placement and rip-up/retry PCB routing.
- Polygonal gridless ground planes.
- Libraries of over 8000 schematic and 1000 PCB parts.
- Bill of materials, DRC reports and much more.

Mixed Mode SPICE Circuit Simulation

- Berkeley SPICE3F5 simulator with custom extensions for true mixed mode and interactive simulation.
- 6 virtual instruments and 14 graph based analysis types.
- 6000 models including TTL, CMOS and PLD digital parts.
- Fully compatible with manufacturers' SPICE models.

Proteus VSM - Co-simulation and debugging for popular Micro-controllers

- Supports PIC, AVR, 8051, HC11 and ARM micro-controllers.
- Co-simulate target firmware with your hardware design.
- Includes interactive peripheral models for LED and LCD displays, switches, keypads, virtual terminal and much, much more.
- Provides source level debugging for popular compilers and assemblers from Crownhill, IAR, Keil, and others.

New Features in Version 6

- Drag and drop toolbars.
- Visual PCB packaging tool.
- Improved route editing.
- Point and click DRC report.
- Multiple design rules (per net).
- Multiple undo/redo.

Call Now for Upgrade Pricing



labcenter

Electronics
53-55 Main Street, Grassington. BD23 5AA

Tel: 01756 753440
Fax: 01756 752857

Contact us for
Free Demo CD

www.labcenter.co.uk
info@labcenter.co.uk