



TRIAx



# User Guide

## House Distribu/on Amplifier

Model

**GHV 900 Series**

Item no.

**892288**

Version

02 - 2014

EN

[triax.com](http://triax.com)

# In the box

1 x Amplifier with jumpers

1 x User Guide

The **GHV 900 Series** is a low noise coaxial House Distribution Amplifier, for use in smaller to medium CATV distribution networks in multi dwelling houses.

The GHV 900 Distribution Amplifier Series share a modular design with return path all-on-board for easy setting and installation

Rotary switches and jumpers provide for readable, easy and reproducible setting of attenuation and equalization, maintaining a non-breakable signal path down- and upstream to avoid down-time.

- Cost optimized 1 GHz technology
- Downstream 20 to 40 dB amplification / High output level
- Adjustable attenuation and equalization settings in 1dB steps using rotary switches and jumpers.
- Switchable operation modes: VHF Band I (RC=OFF) or 5-65 MHz Return Path (RC=ON)
- Selectable Return Path: On/Off, Active/Passive.
- Upstream switchable amplification ( except GHV 920 )
- All-on-board return path technology, all features available without module.
- Optional Automatic Return-path Activation (ARA) module connector. (Switchable return path blocker for Noise suppression)
- All connectors are F-connector female, individually mounted.
- -20dB input- and output- Test connectors
- Extensive ESD- and Surge-Protection
- Unit is Mains fed via an EU-type power plug.
- High output level low power consumption

©

Copyright © Triax A/S

Copying and distribution only with prior written permission from Triax A/S



Triax A/S, Bjørnkærvej 13, 8783 Hornsyld. [www.com](http://www.com)

# Table of Contents

## Table of Contents

	Page
<b>1. Introduction</b>	<b>12</b>
1.1 Description	12
1.2 Who should read this?	12
1.3 Abbreviations and Symbols	12
1.4 Warranty	12
<b>2 . Security</b>	<b>12</b>
2.1 Important	12
2.2 Requirements and wrong handling	12
2.3 Safety precautions	13
<b>3. Installation</b>	<b>13</b>
3.1 Local Setup	13
3.2 Mounting	13
<b>4. Settings</b>	<b>14</b>
4.1 Open the Amplifier	14
4.2 Overview	14
4.3 Setings	15
4.4 Setup switches and Jumpers	15
4.5 Close the Amplifier	15
<b>5. Technical Specifications</b>	<b>16</b>
<b>6. Maintenance/Service</b>	<b>16</b>
<b>7. Recycling</b>	<b>16</b>

# Introduction

1 Introduction	Multimedia capable House Distribution Amplifier for smaller House installations.
1.1 Description	<p>All functional parts such as Pre-amplifier, Diplex filters, Return Channel Amplifier and their settings and adjustment components are fully integrated onto the circuitboard of the Amplifier. This allows a complete installation and setup based upon local requirements.</p> <ul style="list-style-type: none"><li>• All Amplifier attenuation and slope-adjustments are done via a 16-step rotary switch in 1dB steps</li><li>• The GHV Series comprise versions with 20 to 40dB downstream amplification.</li><li>• Easy setup for switching between return channel (5-65 MHz) and VHF Band I.</li><li>• Return channel settable for: "active", "passive", "ON" (default) or "OFF"</li><li>• Return channel amplification setting allows to switch Gain (except GHV 920).</li><li>• Suitable for CATV Cable Operators.</li></ul>
1.2 Who should read this?	This User Guide is suitable for Technicians, Installers and other Educated and Authorized Personnel who Setup, Repair and Maintain Cable Network Distribution Networks.
1.3 Abbreviations and Symbols	<ul style="list-style-type: none"><li>• Important Points</li><li> Actions</li><li> Conclusions</li><li> Info</li></ul> <p>Remarks and tips for the practical use of the units.</p>
1.4 Warranty	Please refer to your local sales representative for the Warranty Terms of this product. Unauthorized handling, installation and setup voids any warranty claim.
2 - Security	
2.1 IMPORTANT	<b>WARNING!</b> Non-compliance to the safety precautions for this unit can cause Injuries, Death and can also damage the unit.
2.2 Requirements and wrong handling	Only Technicians, Installers and other Educated and Authorized Personnel should Install, Setup, Repair and maintain this unit under full compliance to the safety precautions. Damage caused by unauthorized, wrong Installation or use, bad connections or other unauthorized handling voids the Warranty.

# Installation

## 2.3 Safety precautions

### **BEWARE:**

You must adhere to the Safety Precautions of EN 60728-11

- Before you start working on the installation, turn off Mains Power to the circuit.
- Only let an authorized Electrician do the Mains power plug installation if needed.
- Never do Installation or Repair during Thundr Storms.
- Always connect the network by use of the Grounding Terminal of the device (with a copper wire (diameter min. 4 mm<sup>2</sup>) to the Building Grounding Terminal!

## 3. Installation

Before you start working on the installation, turn off Mains Power to the circuit!  
Observe the safety precautions!

### 3.1 Local setup

Mount the Amplifier...

- Horizontal, free on the wall and so that the convection cooling of the unit is not compromised.
- On non-flammable material (Concrete or Brick Wall)
- In a dustfree environment, protected against moisture and fluid. (Drop- and spray water)
- Not in a spot with direct Sun radiation (e.g.. On the Roof)
- Not directly along with Heat Sources (e.g. Heating Room)
- In compliance with the highest allowed working Temperature (measured at the Airflow under the Amplifier)

### 3.2 Mounting

Wallmounting:

- ☞ Fasten the Amplifier according to its measurements (See Fig. 1.) on the wall. (Screws- $\varnothing$  max. 4.8 mm, Distance between holes 158 mm)
- ☞ Create a Grounding potential using the screw A and a sufficient fitted and stable cable (diameter min. 4 mm<sup>2</sup>)
- ☞ Connect the RF-Input B and the RF-Output C. Make sure you get perfect connection between Coax cable and Connector.
- ☞ Turn on the Mains Power to the circuit again.

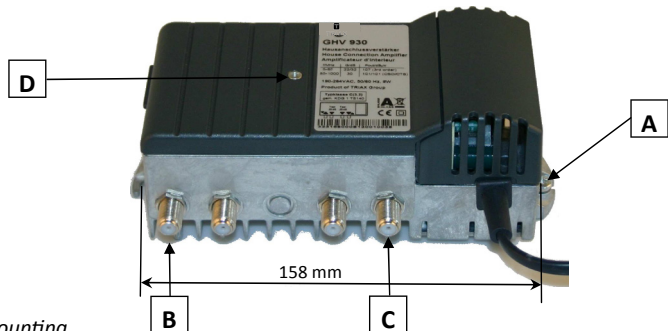

Fig. 1 Mounting

# Settings

## 4. Settings

### 4.1 Open Amplifier

### 4.2 Overview

Remove the top cover of the Amplifier by removing screw D (see Fig. 1)

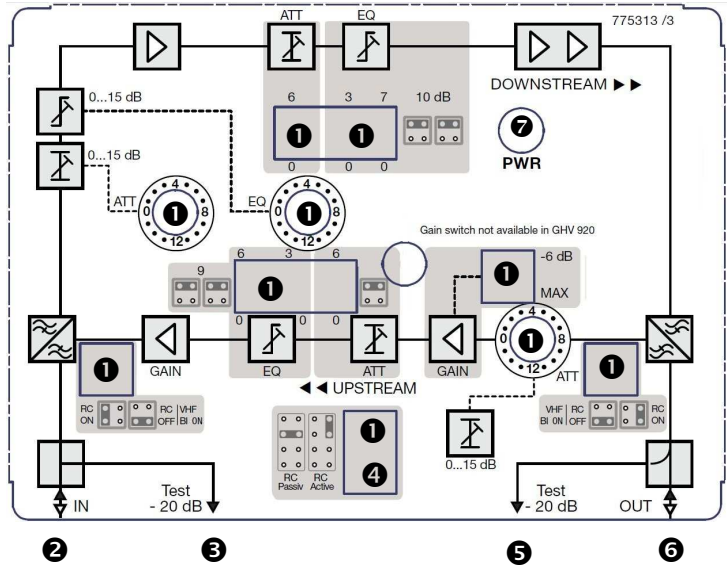

Fig. 2 Inside view

- ❶ Setting elements/Rotary switch
- ❷ RF-Input, RP-Output
- ❸ Test connector RF-Input / RP-Output (bidirectional) -20dB
- ❹ Connector for optional ARA module
- ❺ Test connector RF-Output (uni-directional) -20dB
- ❻ RF-Output, RP-Input
- ❼ Power ON/OFF LED

# Adjustments

## 4.3 Settings

The Amplifier is configured using Rotary Switches and Jumpers as shown:

See Fig. 3	Downstream	Setting Range	Default setting	Setting element, Jumper Fig.
1 / 11	Return Path-ON/OFF	ON/OFF	ON	Jumper, A
2	Attenuator (Input) in 1dB-Steps	0-15 dB	0 dB	Rotary switch
3	Slope (Input) in 1dB-Steps	0-15 dB	0 dB	Rotary switch
4	Attenuator (Interstage)	0 / 6 dB	0 dB	Jumper, B
5	Slope (Interstage)	0 / 3 / 7 / 10	0 dB	Jumper, B
<b>Upstream/Return Path</b>				
6	Return Amplifier Gain*	-6 dB	Max Gain	Jumper, B
7	Attenuator (Input) in 1 dB-Steps	0/15 dB	0 dB	Rotary switch
8	Slope (Interstage)	0 / 3 / 6 / 9	3 dB	Jumper, B
9	Attenuator (Interstage)**	0 / 6 dB	0 dB	Jumper, B
10	Return Path Active/Passive	Active/Passive	Active	Jumper, C

\*) not in GHV 920

\*\*\*) not in GHV 920 and GHV 930

## 4.4 Setup Switches and Jumpers

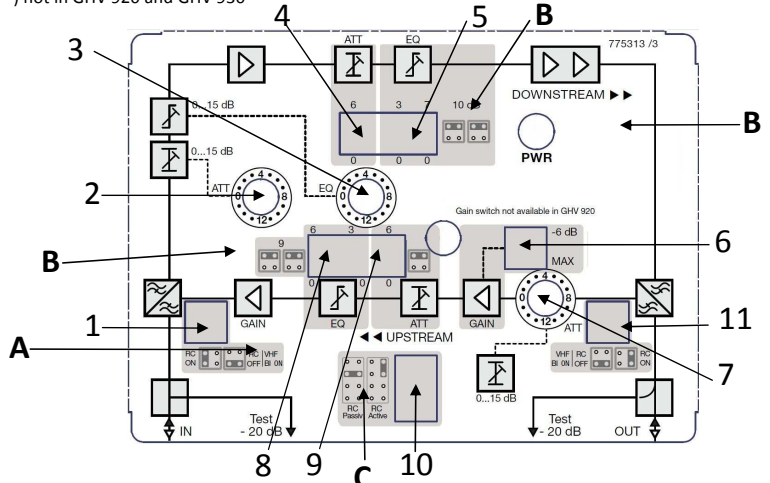

## 4.5 Close the Amplifier

Mount the Amplifier cover

Fig. 3 Position of Jumpers/Setting elements



# TRIAX

connecting the future

## 5. Technical Specifications\*

Type	GHV 920	GHV 930	GHV 935	GHV 940
Article number	323150	323158	323162	323166
<b>Forward path (downstream)</b>				
Frequency Range (VHF BI on / RC on)	MHz	47...1006 / 85...1006		
Max. Output level**, Slope 0/7 dB	dBµV	98/100	103/105	103/105 / 107/109
Gain	dB	20	30	35 / 40
Attenuation, Interstage, Jumper	dB	0 / 6		
Attenuation, Input	dB	0...15 (1dB-Steps)		
Slope, Interstage, Jumper	dB	0 / 3 / 7 / 10		
Slope, Input	dB	0...15 (1dB-Steps)		
Noise Figure	dB	7		
<b>Return path (upstream)</b>				
Frequency Range (VHF BI on / RC on)	MHz	- / 5...65		
Max. Output level (IMA2 / IMA3) > 60dB	dBµV	96/117		98/119
Upstream load (KDG 1TS 140)		Typ C	Typ C	Typ C / Typ D
Gain (-6dB** / max)	dB	20 fixed	22/28	24/30 / 26/32
Attenuation, Interstage, Jumper	dB	-		0 / 6
Attenuation, Input	dB	0...15 (1dB-Steps)		
Slope, Interstage, Jumper	dB	0 / 3 / 6 / 9		
Noise Figure	dB	5		
<b>General</b>				
Linearity	dB	± 1		
Return loss (@40MHz, -1.5dB/Oktave)	dB	>18		
Test connector (75Ω) Input/output/test		F-female		
Test connector In-/Output (-20dB)		Bi- / Uni-directional		
<b>Operating conditions</b>				
Diameters W x H x D	mm	169 x 76 x 65		
Input supply voltage	V-/Hz	190—264 / 50...60		
Power Consumption (typ.)	W	4,9	6,0	6,4 / 9,5
ESD/Surge protection	kV	10 / 1		
Operating temperature	°C	-25...+55		
Safety/Protection		Class II / IP 20		
Weight	g	750		

\*) Measured according to EN 60728-3 \*\*\*) CTB and CSO > 60 dB (42 ch.) \*\*\*) Switching gain in first amplifier by using one jumper

## 6. Maintenance / Service

Repair only by an Authorized Technician and Service Center.

Please refer to Your Sales Representative for more info.

You must adhere to the Legal Requirements and precautions that applies to your local Area for Recycling this product.

[triaux.com/support](http://triaux.com/support)



Copyright © 2016 TRIAX. All rights reserved. The TRIAX Logo and TRIAX, TRIAX Multimedia are registered trademarks or trademarks of the TRIAX Company or its affiliates. All specifications in this guide are subject to change without further notice.

TRIAX A/S | Bjørnkærvej 3 | DK-8783 Hornslyd | Denmark