

The “Leapfrog” Method Of Switching Amplifier Control Loop Design

analog@ieee.org - 1996

The leapfrog design method extends active damping techniques to incorporate an unlimited number of output filter sections within a switching amplifier feedback loop. By working in steps from the power switching stage outward, the process of designing gain coefficients for each feedback filter component is simplified to a first order problem. At each stage the amplifier's impedance characteristic leapfrogs between that of current and voltage source (hence the name). The leapfrog method breaks the design problem into manageable steps, and turns what would otherwise be a practically intractable problem with four, six or more independent variables, into a series of straightforward choices for each feedback coefficient.

Switching amplifiers are attractive for high power audio applications because of their inherently low conduction/blocking losses. This results from maintaining the output power devices in either a fully saturated or cut-off state such that they never simultaneously support large currents and voltages as is typical of standard linear audio amplifiers. This switching characteristic can provide an important efficiency advantage over standard linear amplifiers if the losses from the switching transitions are also kept to a relatively low level. Toward this end it is desirable to switch at as low of a frequency as is compatible with closed-loop system bandwidth and output impedance requirements (a switching amplifier is actually a high level digital sampled data system with its ensuing Nyquist sampling effects which limit maximum bandwidth to no more than one half the switching frequency).

Another significant complication often arises because of the need to strictly limit the level of switching ripple components on the amplifier's output without restricting the amplifiers ability to deliver rail-to-rail audio signals at 20 kHz. This requires the use of an output recovery filter with multiple L/C sections and with pole locations just above the audio pass band. To optimize closed-loop system bandwidth and output impedance necessitates that the feedback system be able to track and compensate the rapid phase shift stemming from the output filter's high Q poles and zeros, the location of which will vary dynamically due to current and temperature dependent shifting of the component values. Note that, in high efficiency power applications, dissipative elements may not be readily used in the recovery filter to control L/C resonances.

This has not been an easy problem to solve using traditional techniques. Standard compensation methods with opamps, resistors and capacitors fail because it is not possible to match and track the frequency characteristics of the high Q L/C filter sections. Typically, the amplifier's feedback loop will include none or only the first of the output filter sections within its control loop. This approach degrades the accuracy of the amplified audio signal.

In some prior switching amplifiers, the control loop has been designed using active damping techniques to track filter component shifts, manage output filter Q and extend bandwidth. With this method, a sensed signal directly proportional to output filter capacitor current is an integral part of the feedback loop. This insures direct, accurate tracking and control of output filter resonances, and allows maximum loop gain-bandwidth in the face of a single L/C filter section.

The leapfrog design method described below extends the active damping technique to incorporate an unlimited number of output filter sections within the feedback loop, and describes how to choose the gain coefficients for each feedback filter component by working in steps from the power switching stage outward. As the gain coefficient for each component is chosen, and that component is incorporated within the amplifier's black box boundary, the impedance characteristic the amplifier presents at its output changes to a current source if the component is an inductor or to a voltage source if the incorporated component is a capacitor. As

each component is swallowed up, the overall closed loop bandwidth must be reduced by a small factor (about 1.5 or so). Thus, the amplifier's output characteristic leapfrogs between that of a current and voltage source (hence the name). This simplifies the design process of each succeeding gain coefficient to a first order problem. The leapfrog method breaks the design problem into manageable steps, and turns what would otherwise be a practically intractable problem with four, six or more independent variables, into a series of straightforward choices for each feedback coefficient.

The figure below will be used to illustrate the leapfrog design process for a four-element ladder filter network. Working from the power switch to the output (left to right), the voltage command to the power stage/modulator is the sum of the positive feedback signal of the voltage appearing on the output side of L_1 and the negative feedback signal of the inductor current. Note that the modulator and totem pole output stage is approximated as a voltage controlled voltage source with delay due to sampled data nature of the pulse

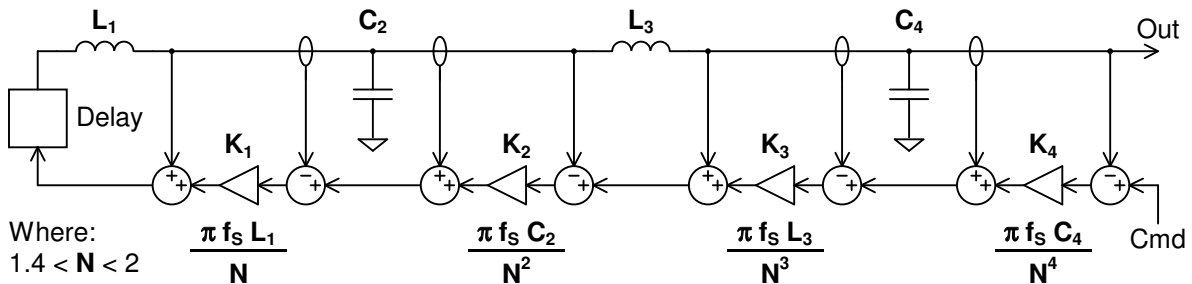

width modulation process. The unity gain positive feedback term of the load side voltage from the inductor serves to keep the voltage across the inductor (and hence its current) constant in the face of load side voltage perturbations. The negative feedback signal of inductor current rolls off with a single pole due to the rising impedance of inductor L_1 . Gain K_1 is set so that loop gain falls to zero somewhat before half the switching frequency (where the switching delay adds 180 degrees phase shift). As the inductor is merged into the black box of the amplifier on the left hand side, the resulting equivalent voltage controlled current source is shown below feeding the next filter element C_2 .

Next, capacitor C_2 is incorporated into the equivalent circuit in exactly a dual nature. Looking at the following figure, the unity gain positive feedback term of load side current out of the capacitor functions to null net current through the capacitor in spite of sudden changes in load current, minimizing the resulting voltage fluctuations. The negative feedback term of capacitor voltage rolls off with a single pole due to the falling im-

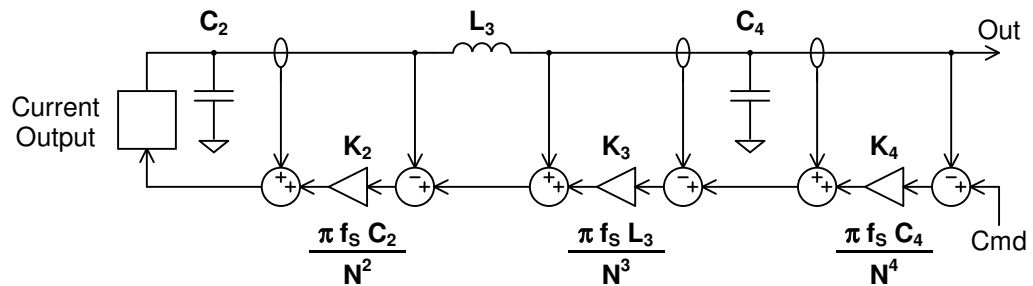

pedance that capacitor C_2 presents to the controlled current source. Gain K_2 for this feedback path is set so that loop gain falls to zero at about two thirds of the current source's bandwidth. The resulting equivalent voltage controlled voltage source is shown below feeding the next filter element L_3 .

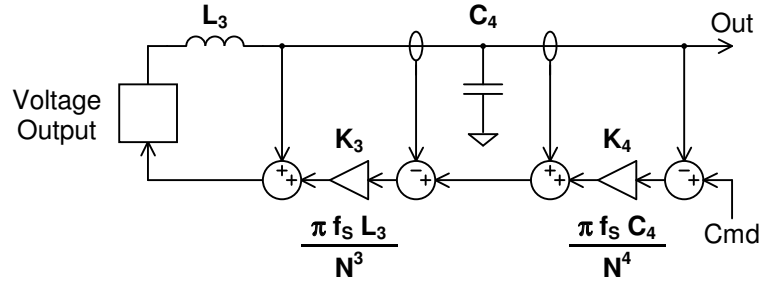

Where:
 $1.4 < N < 2$

Now the leapfrog method has come full circle to the starting conditions of a controlled voltage source feeding an inductor element in an LC filter ladder. Just as before, this element is incorporated into the system by applying the appropriate amounts of positive and negative feedback. Gain K_3 for this feedback path is set so that closed loop gain is about two thirds of what it was before. The resulting equivalent voltage controlled current source is shown below feeding the next filter element C_4 .

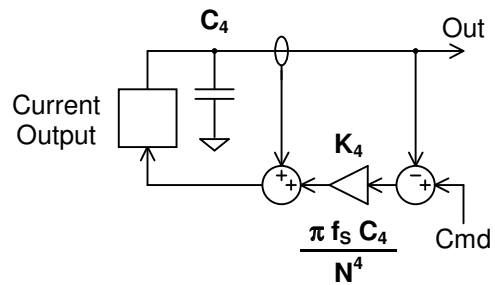

Where:
 $1.4 < N < 2$

The process continues until all the filter elements are incorporated into the amplifier, yielding a well controlled, component insensitive, switching amplifier with the maximum possible bandwidth. These advantages come at a cost of an extensive feedback network distributed throughout the switching amplifier's recovery filter ladder.

In practice, both the sensing and feedback amplifier circuitry can be greatly simplified by combining adjacent signal paths. In particular, combining stages removes the need to reproduce dc signals in the sensing circuitry. Recognizing that the difference of inductor currents must flow through the capacitor on the common node between adjacent stages justifies using a simple current transformer to sense this difference current. Likewise, recognizing that the difference of capacitor voltages must appear across the interposing inductor justifies using a simple floating winding to sense the difference voltage.

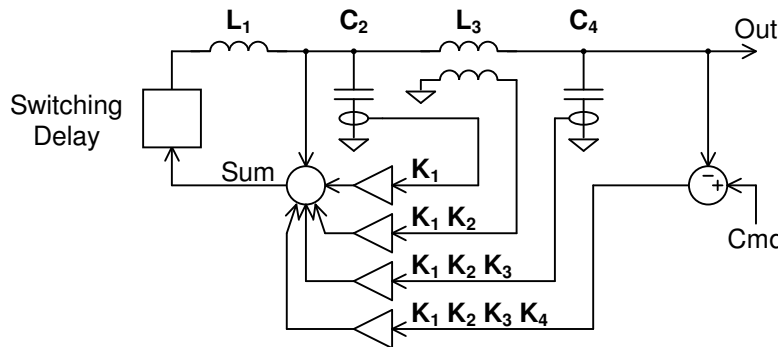

All of the distributed gain terms are easily consolidated into a single summing amplifier by simply accounting for the cumulative gain terms in the path for each signal as shown above.

Following these constructs results in a switching amplifier system that is both practical and simple, yet easily accommodates a recovery ladder filter network of any length within its feedback path.

The following schematics were simulated in LTspice in order to demonstrate and confirm the principles of the leapfrog method of switching amplifier design. As expected, the simulation output from the three variations was absolutely identical, verifying the validity of the topological manipulations.

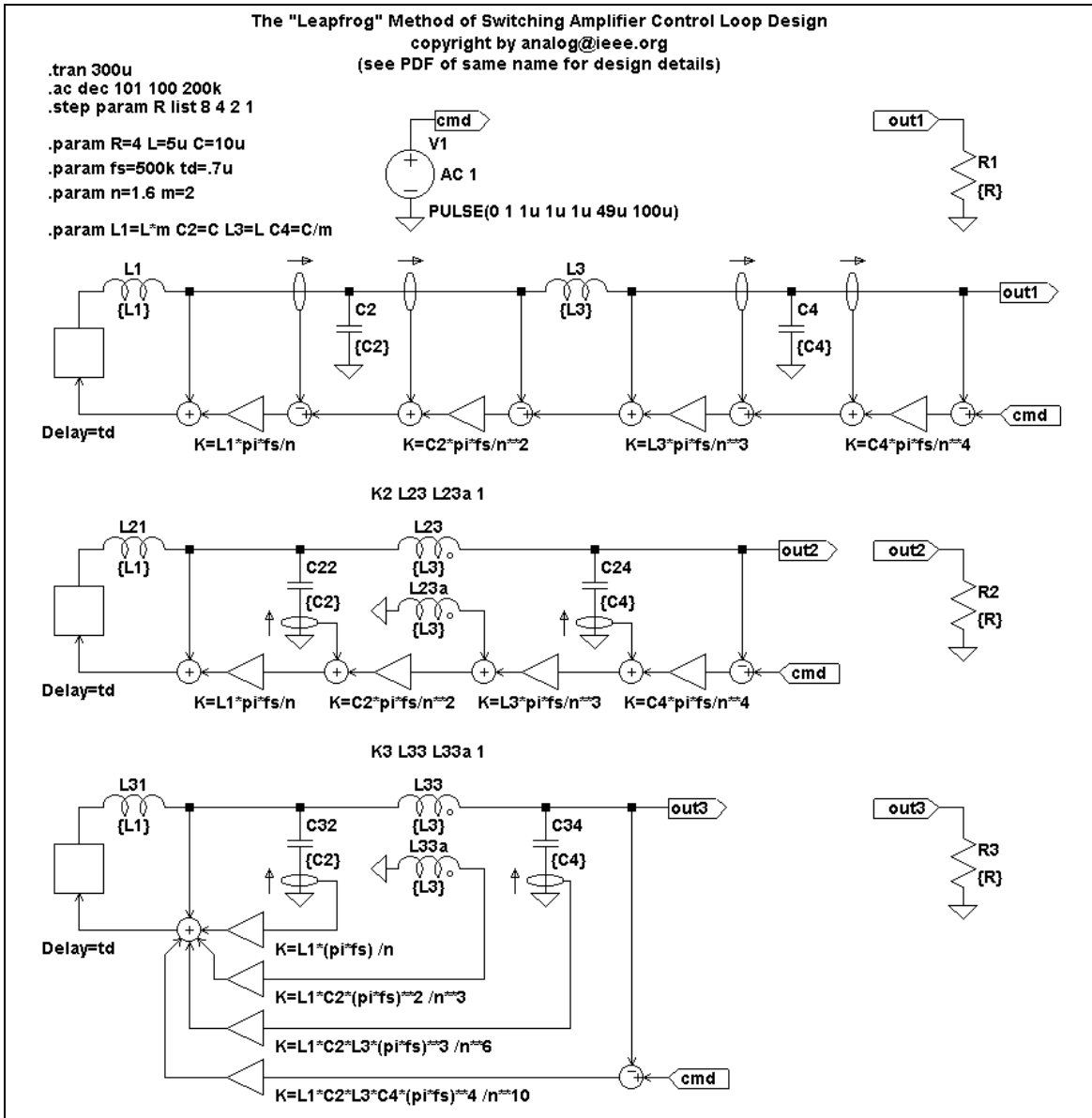

Typical output from ac frequency response and 10kHz square wave transient response is presented below, with each showing the effect of stepping the load resistor from 1 to 8 ohms. Note that f_s represents the effective sampling frequency which may be quite different from the nominal switching frequency. For example, in a free-running, self-oscillating design, the effective sampling frequency would be very close to the lowest switching frequency during dynamic excursions and not the typically 3-to-4-times higher quiescent operating frequency. Likewise t_d represents the effective worst-case delay rather than the typical delay. Thus, the rather high f_s and low t_d of the simulation would be difficult to achieve in practice unless the design employed multiple, parallel, staggered phase output stages feeding the recovery filter. (This technique multiplies the sampling frequency by the number of staggered phase output stages.)

