

Astrosphere Block Diagram

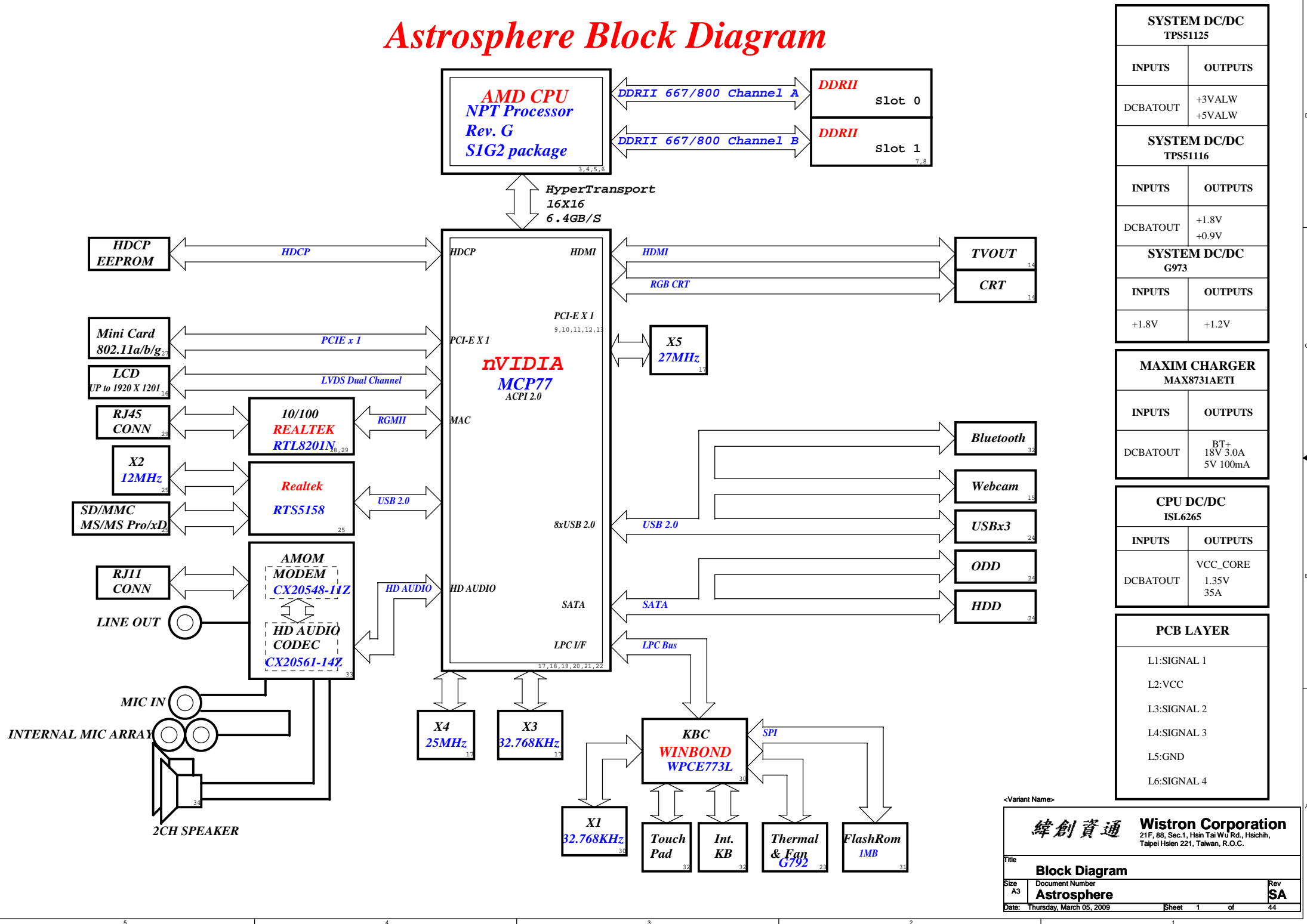

<Variant Name>

緯創資通 Wistron Corporation
 21F, 88, Sec.1, Hsin Tai Wu Rd., Hsichih, Taipei Hsien 221, Taiwan, R.O.C.

Title: **Block Diagram**

Size: A3	Document Number: Astrosphere	Rev: SA
Date: Thursday, March 05, 2009	Sheet: 1 of 44	

CPU_CORE
ISL6265

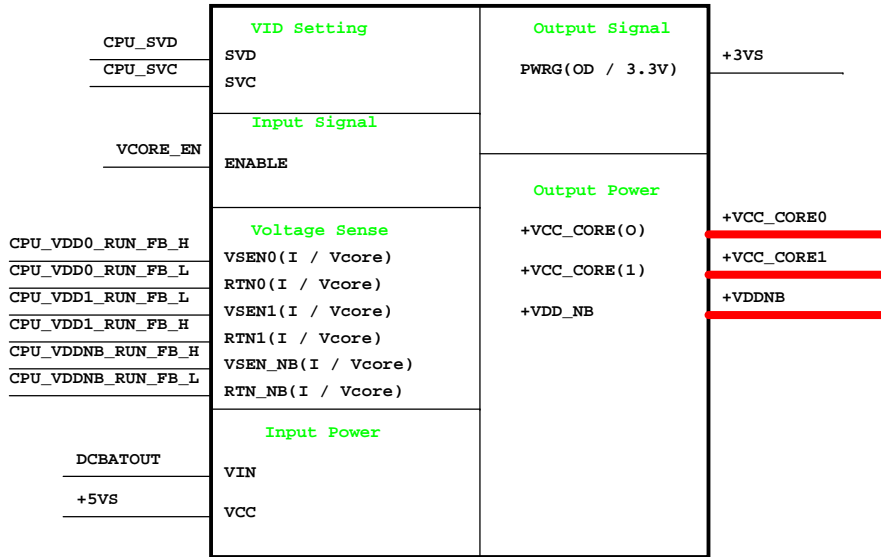

5V/3.3V
TI TPS51125

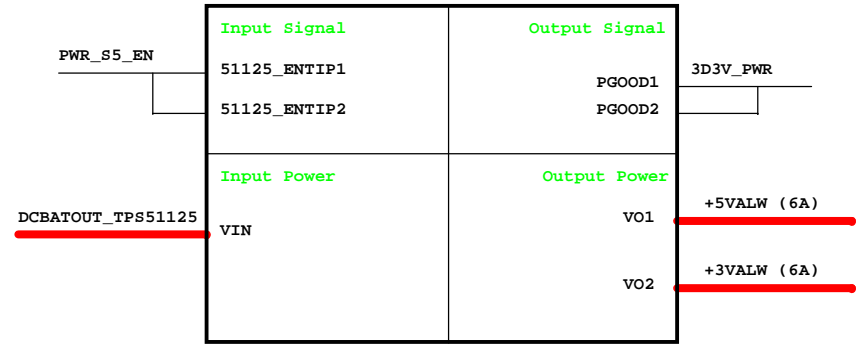

+1.1VS_CHIP
SC412A

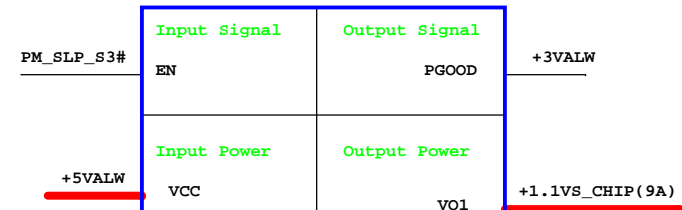

+1.8V/ +0.9VP
TPS51116

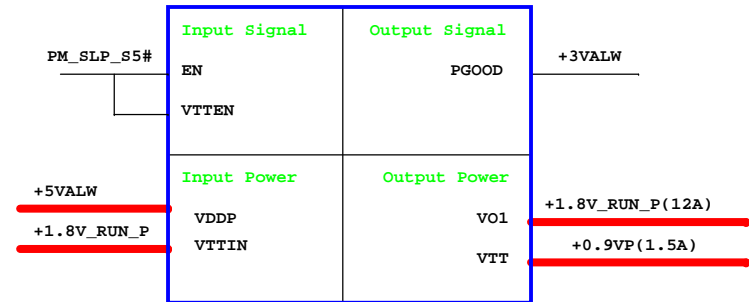

Charger
MAX8731A

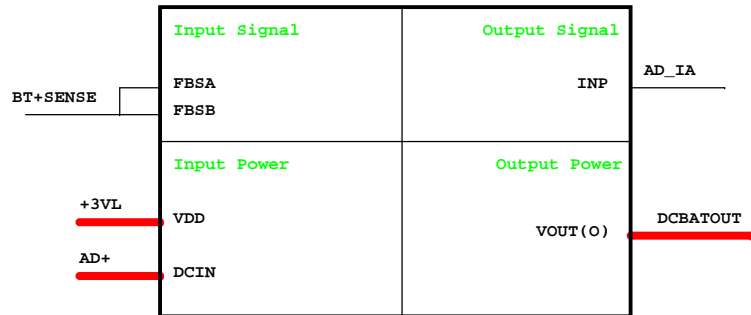

+1.0VS SC471A

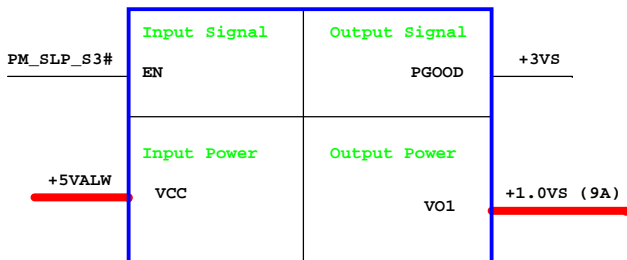

+1.5V_VS
APL5913

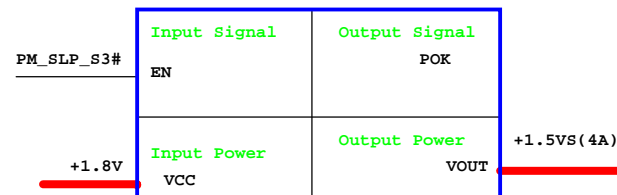

<Variant Name>

緯創資通		Wistron Corporation	
<small>21F, 88, Sec.1, Hsin Tai Wu Rd., Hsichih, Taipei Hsien 221, Taiwan, R.O.C.</small>			
Power Diagram			
Title	Document Number	Rev	
Size A3	Astrosphere	SA	
Date: Wednesday, March 04, 2009 Sheet 2 of 44			

LAYOUT: PLACE CLOSE TO CPU
ALONG HT POWER SHAPE

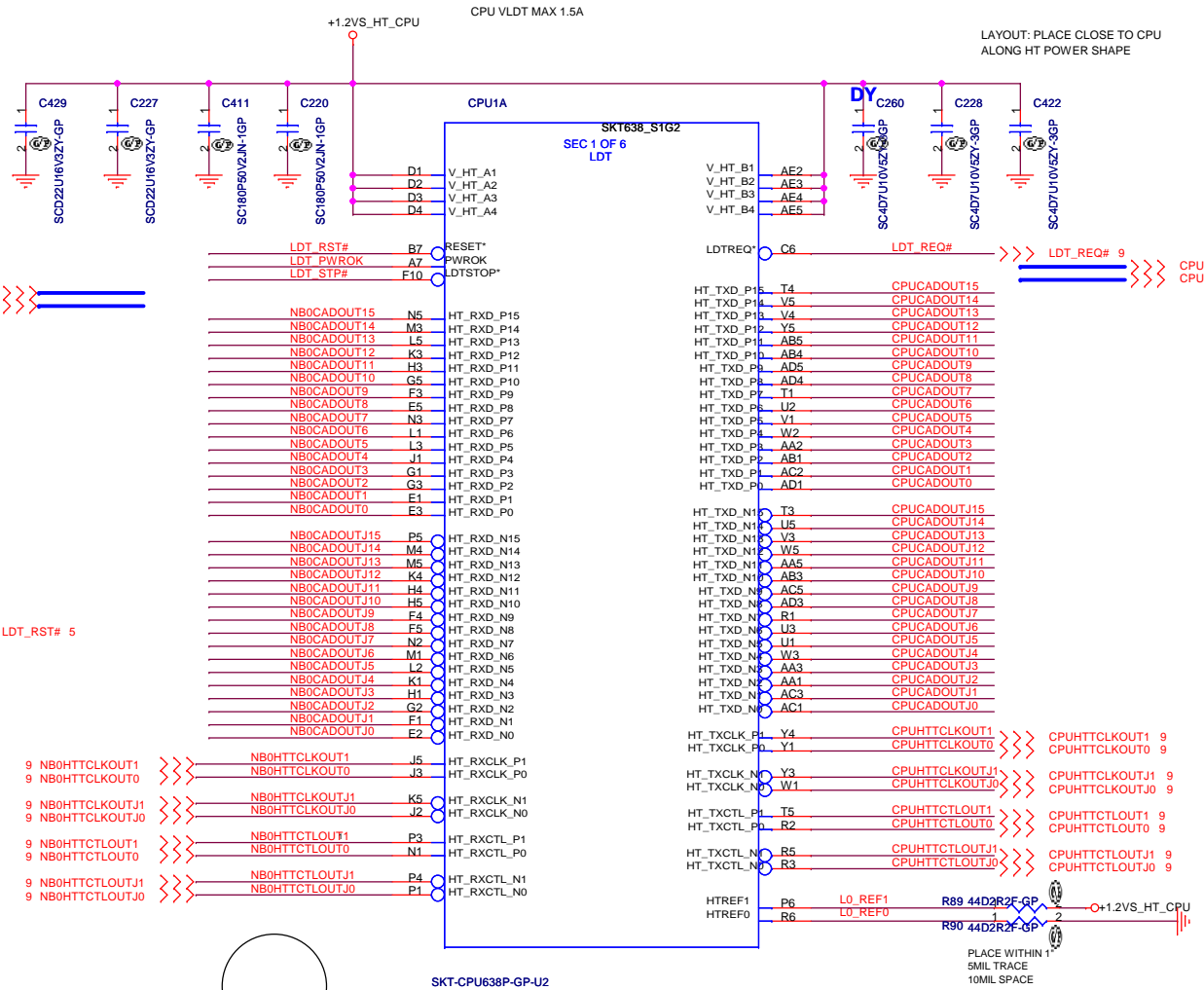

PV 0408

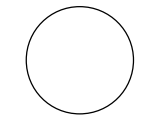
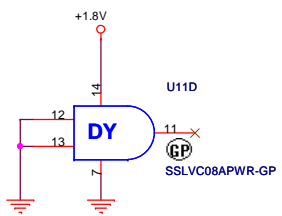
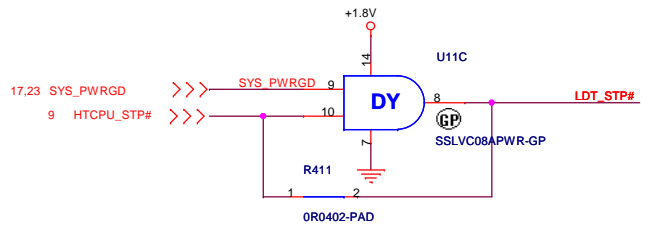
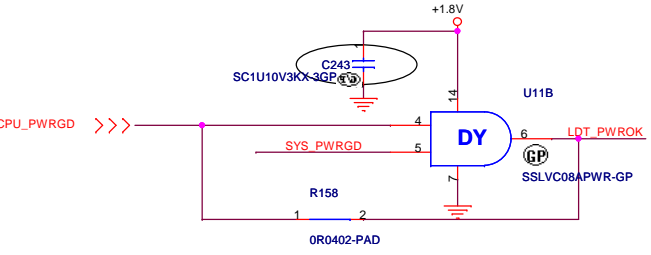
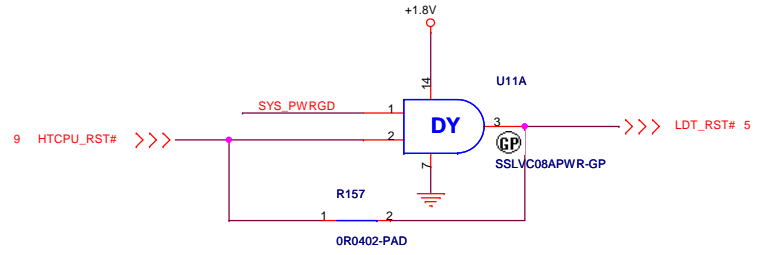
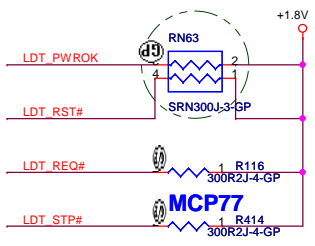

LEAVE NO STUBS
STUFF FOR MCP67
REMOVE FOR HT3/MCP77

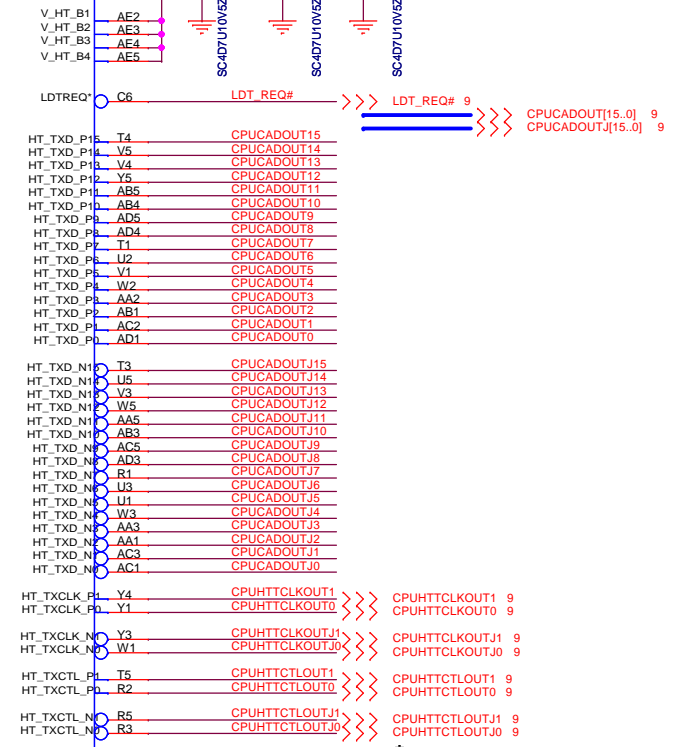

<Variant Name>

緯創資通 **Wistron Corporation**
21F, 88, Sec.1, Hsin Tai Wu Rd., Hsichih,
Taipei Hsien 221, Taiwan, R.O.C.

Title		
CPU(1/4) HT		
Size	Document Number	Rev
A3	Astrosphere	SA
Date:	Wednesday, March 04, 2009	Sheet 3 of 44

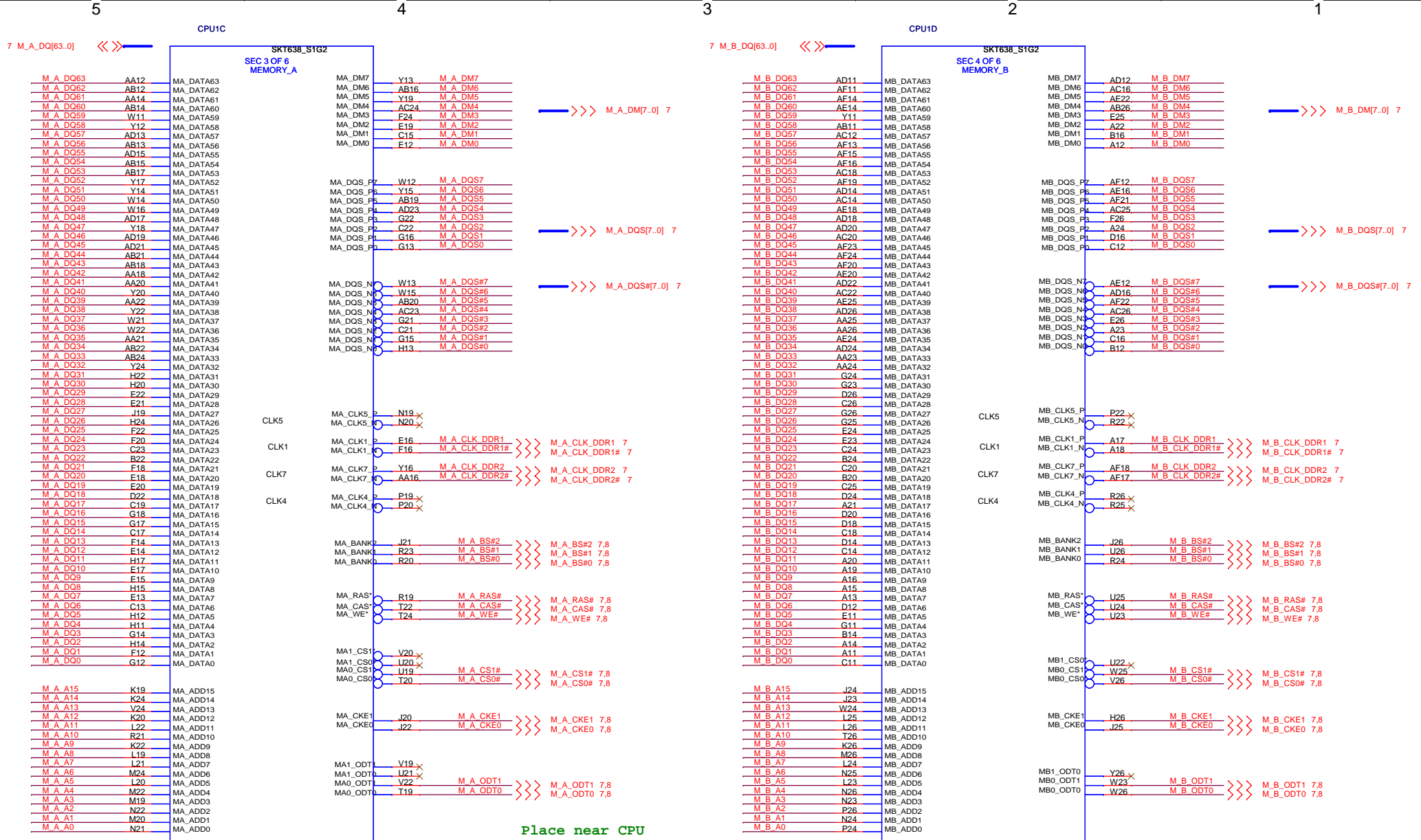

Place near CPU

M_A_A[15..0] 7.8

M_B_A[15..0] 7.8

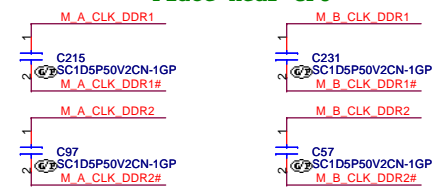

MAX NECKDOWN TO & FROM CAPS IS 500MILS
TRACE FROM CAP TO CPU MUST BE LESS THAN 1200MILS

<Variant Name>

緯創資通 Wistron Corporation	
21F, 88, Sec. 1, Hsin Tai Wu Rd., Hsichih, Taipei Hsien 221, Taiwan, R.O.C.	
CPU(2/4) DDR II	
File	Rev
Size A3	SA
Document Number	Sheet 4 of 44
Date: Wednesday, March 04, 2009	

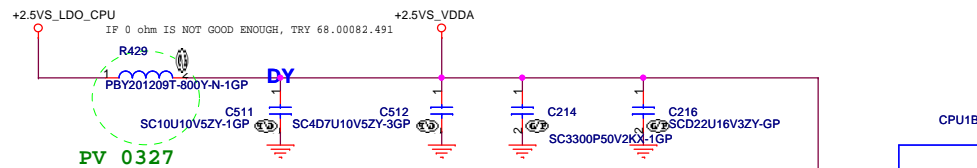

ROUTE AS DIFF PAIR

36 CPU_VDD1_RUN_FB_H
36 CPU_VDD1_RUN_FB_L

36 CPU_VDD0_RUN_FB_H
36 CPU_VDD0_RUN_FB_L

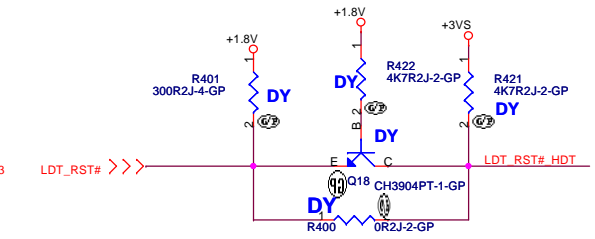
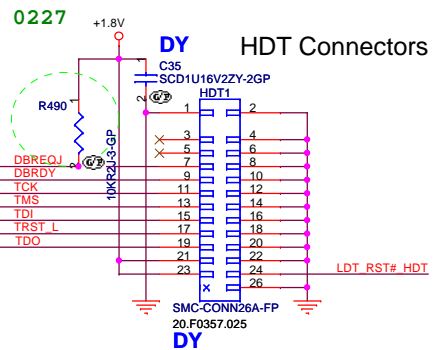
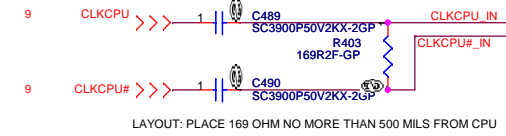

SKT638_STG2
SEC 2 OF 6
MISC

F8	VDDA
F9	VDDA
Y6	VDD1_FB
AB6	VDD1_FB*
F6	VDD0_FB
E6	VDD0_FB*
H6	VDDNB_FB
G6	VDDNB_FB*
W9	VDDIO_FB
Y9	VDDIO_FB*
A9	CLKIN
A8	CLKIN*
G10	DBRDY
AA9	TMS
AC9	TCK
AD9	TRST_L
AE9	TDI
E9	TEST25
E8	TEST25*
G9	TEST19
H10	TEST18
AC8	TEST12
E7	TEST17
F7	TEST16
C7	TEST15
K8	TEST14
C2	TEST10
C4	TEST8
C3	TEST7
AA6	TEST6
W18	NC
M11	NC
B3	RSVD
H19	RSVD
H18	RSVD
B5	RSVD
B18	RSVD
B5	RSVD
C5	RSVD
A5	RSVD
C1	RSVD
A3	RSVD

SKT-CPU638P-GP-U2

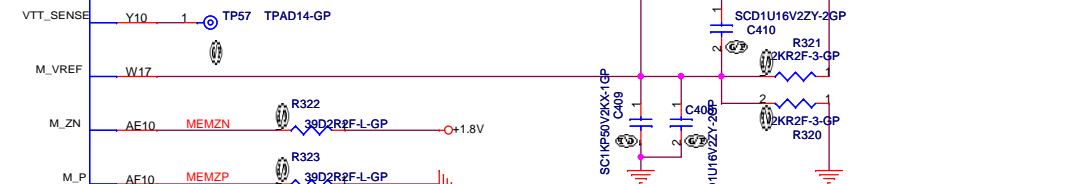
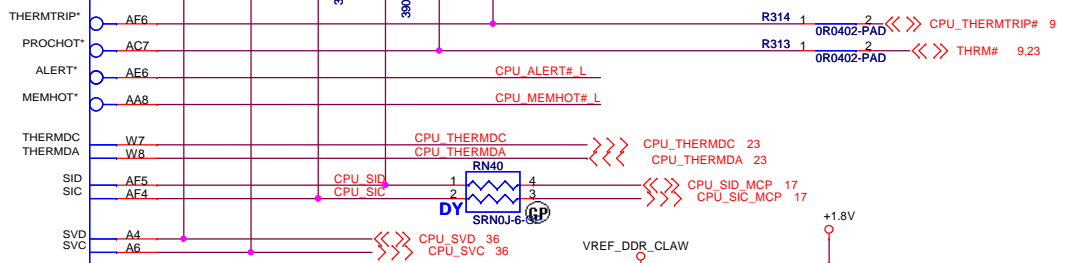
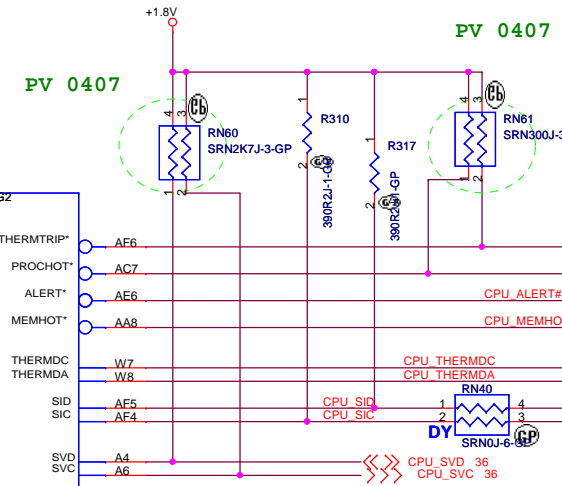

LAYOUT: Locate close to CPU.

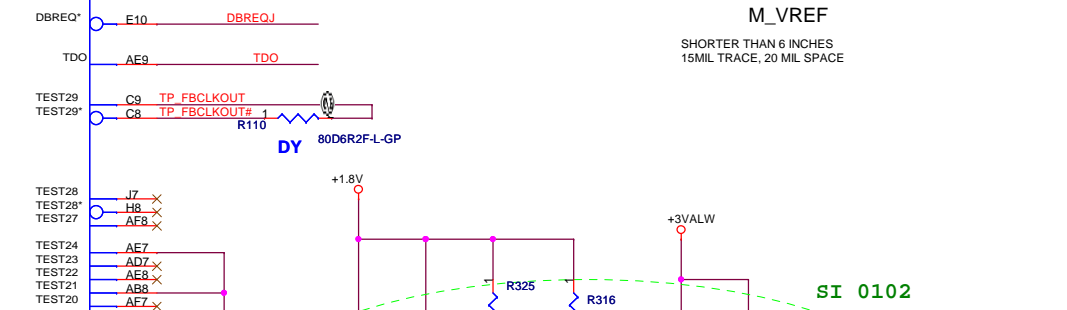

M_VREF
SHORTER THAN 6 INCHES
15MIL TRACE, 20 MIL SPACE

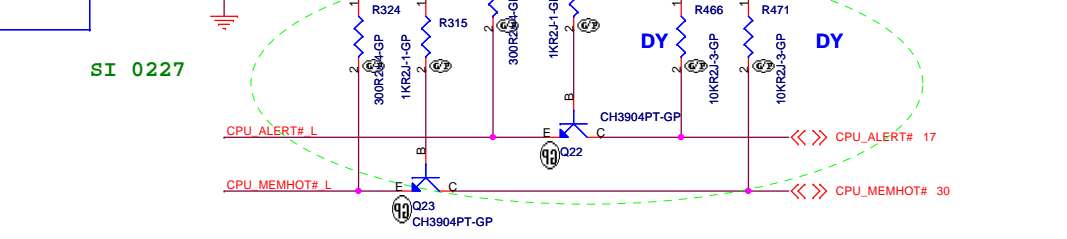

<Variant Name>

緯創資通 Wistron Corporation
21F, 88, Sec.1, Hsin Tai Wu Rd., Hsichih, Taipei Hsien 221, Taiwan, R.O.C.

Title		
CPU(3/4) CONTROL		
Size	Document Number	Rev
A3	Astrosphere	SA
Date:	Wednesday, March 04, 2009	Sheet 5 of 44

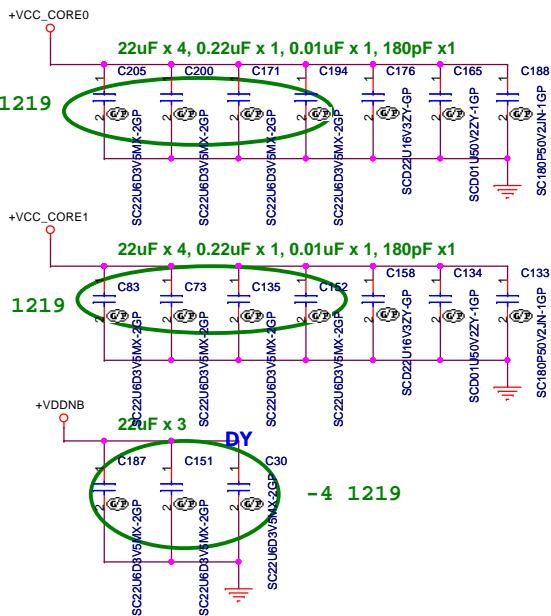
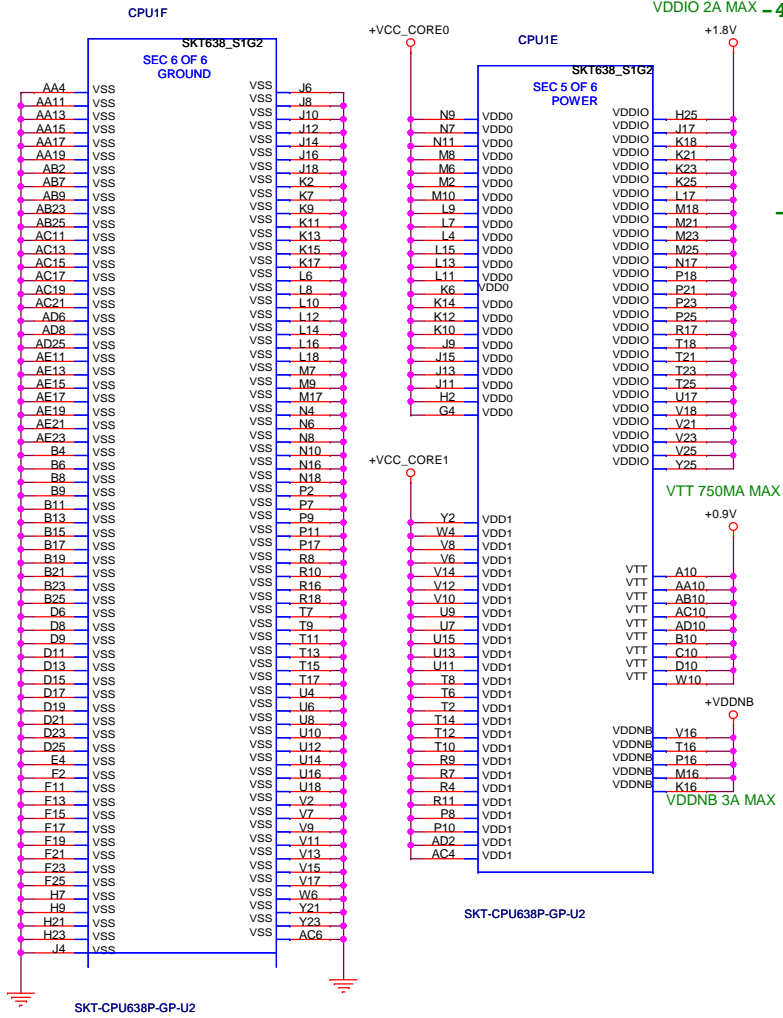

CPU MEMORY VTT

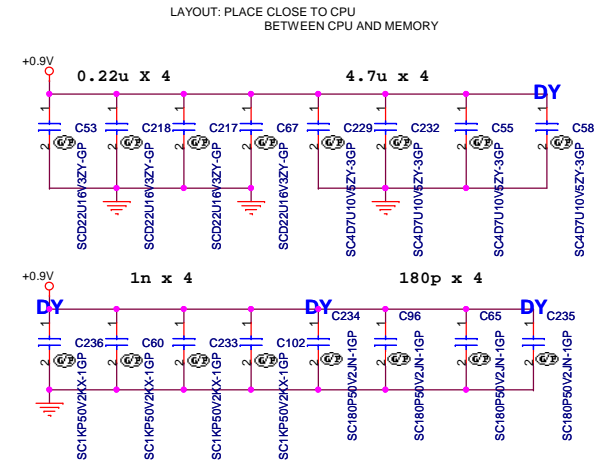

CPU VDDIO

-5 0226

LAYOUT: PLACE UNDER CPU ON BACK

LAYOUT: PLACE CLOSE TO CPU BETWEEN CPU AND MEMORY

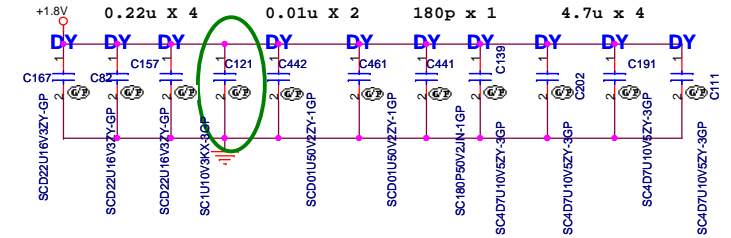
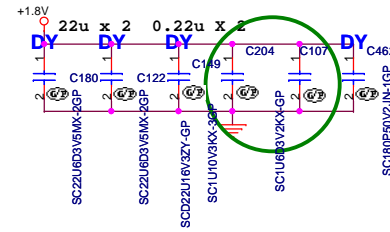

LAYOUT: PLACE CAPS BETWEEN CPU AND MEMORY

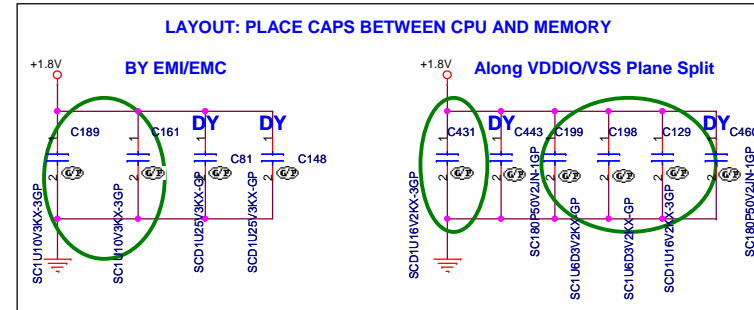

<Variant Name>

緯創資通		Wistron Corporation	
		21F, 88, Sec.1, Hsin Tai Wu Rd., Hsichih, Taipei Hsien 221, Taiwan, R.O.C.	
CPU(4/4) POWER			
Title	Document Number		Rev
Size	Astrosphere		SA
Date:	Wednesday, March 04, 2009	Sheet	6 of 44

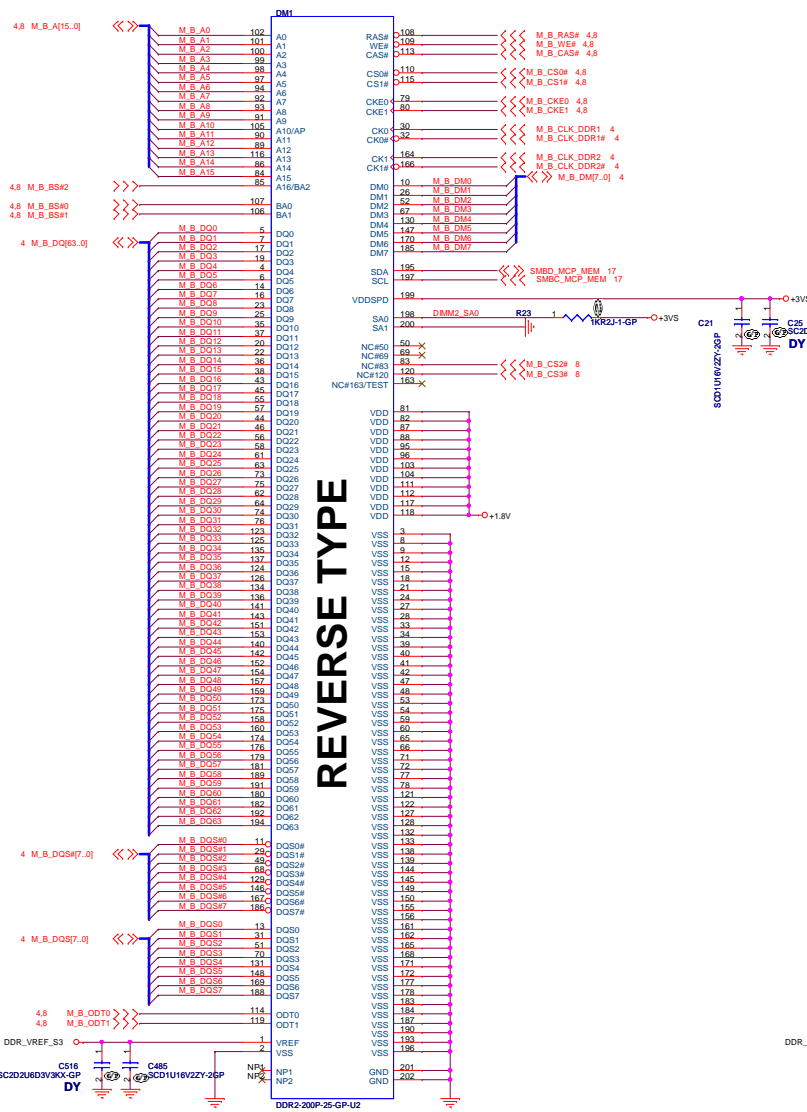

Hi 9.2 mm **DM1 use 62.10017.B51**

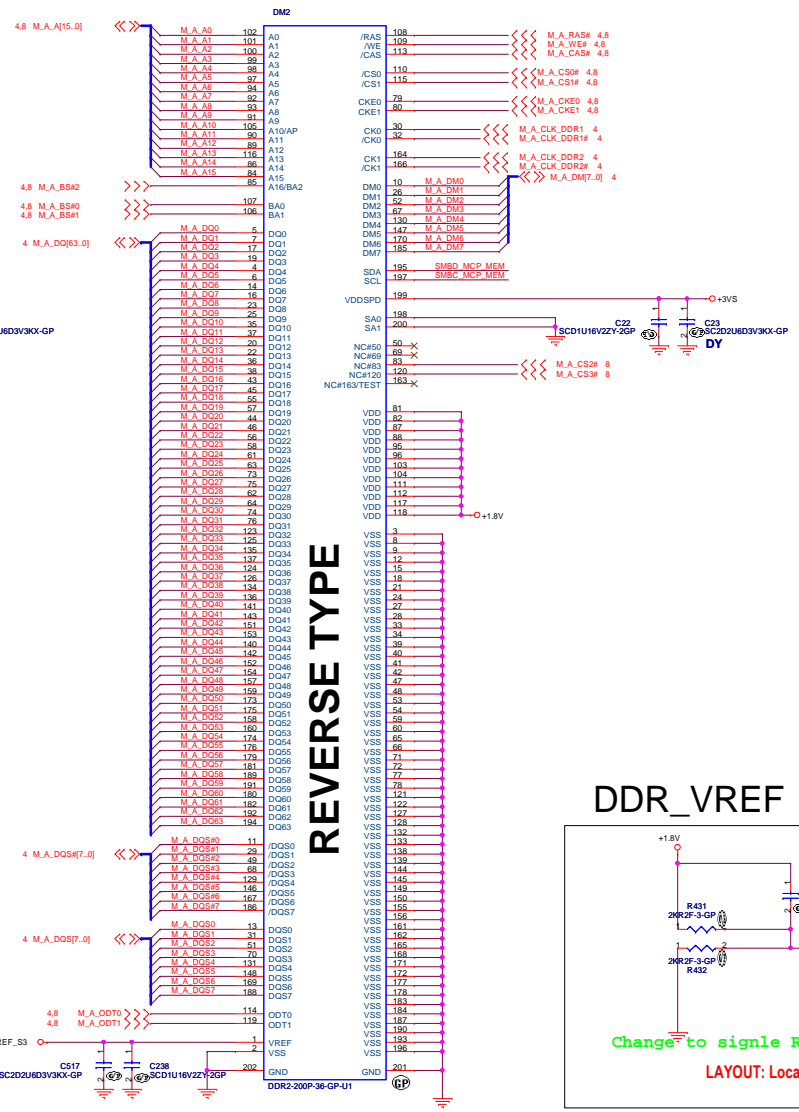

Low5.2 mm **DM2 use 62.10017.E11**

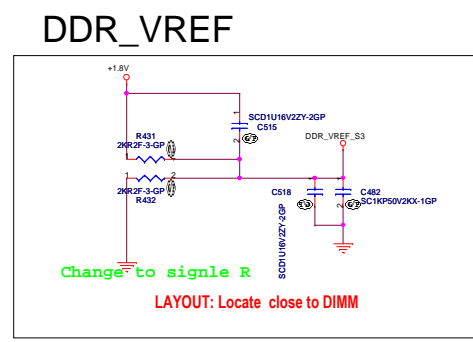

PARALLEL TERMINATION

Put decap near power(0.9V) and pull-up resistor

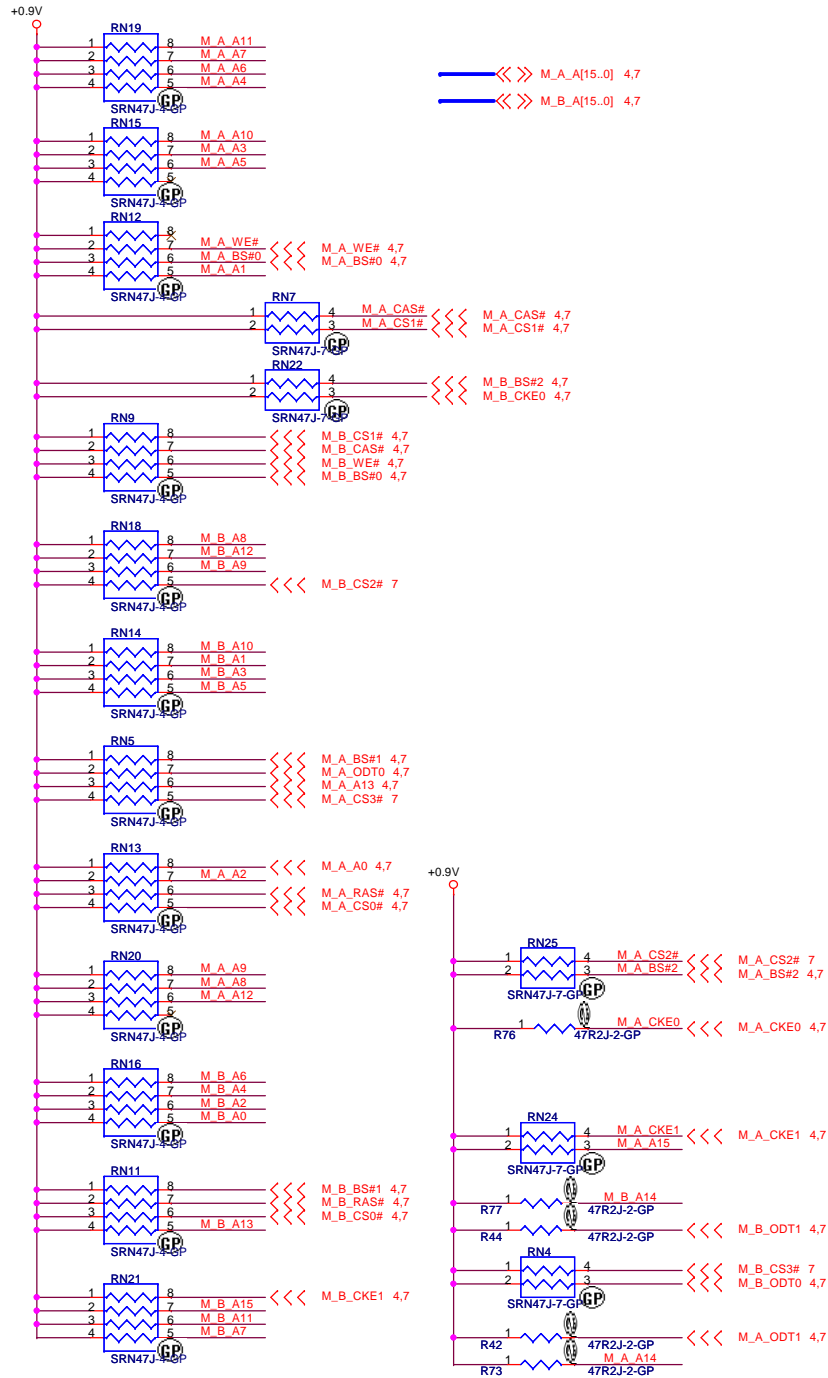

Decoupling Capacitor

Put decap near power(0.9V) and pull-up resistor

0.1u x 15

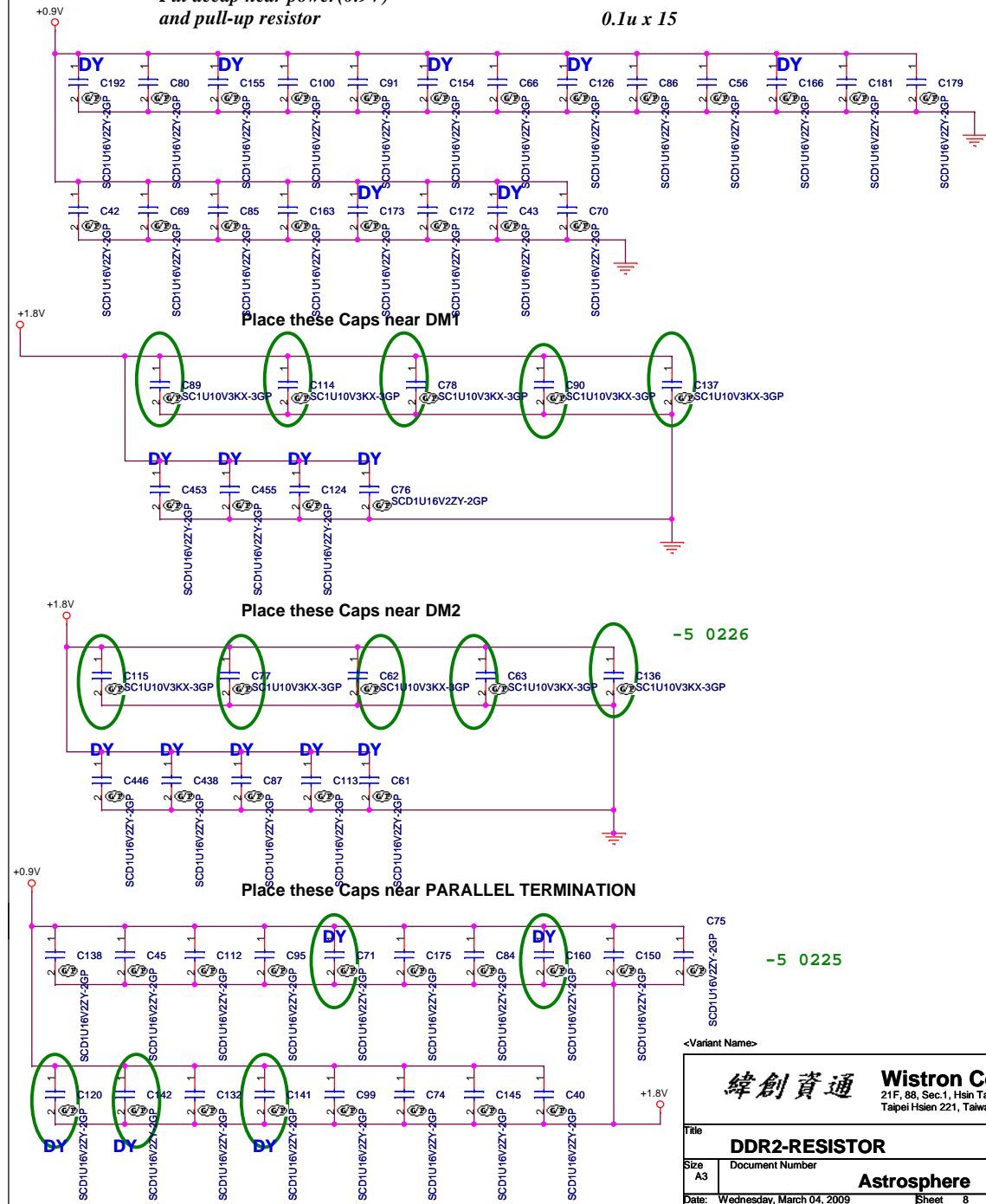

<Variant Name>

緯創資通 Wistron Corporation
21F, 88, Sec.1, Hsin Tai Wu Rd., Hsichih, Taipei Hsien 221, Taiwan, R.O.C.

Title: **DDR2-RESISTOR**

Size: A3 Document Number: **Astrosphere** Rev: SA

Date: Wednesday, March 04, 2009 Sheet 8 of 44

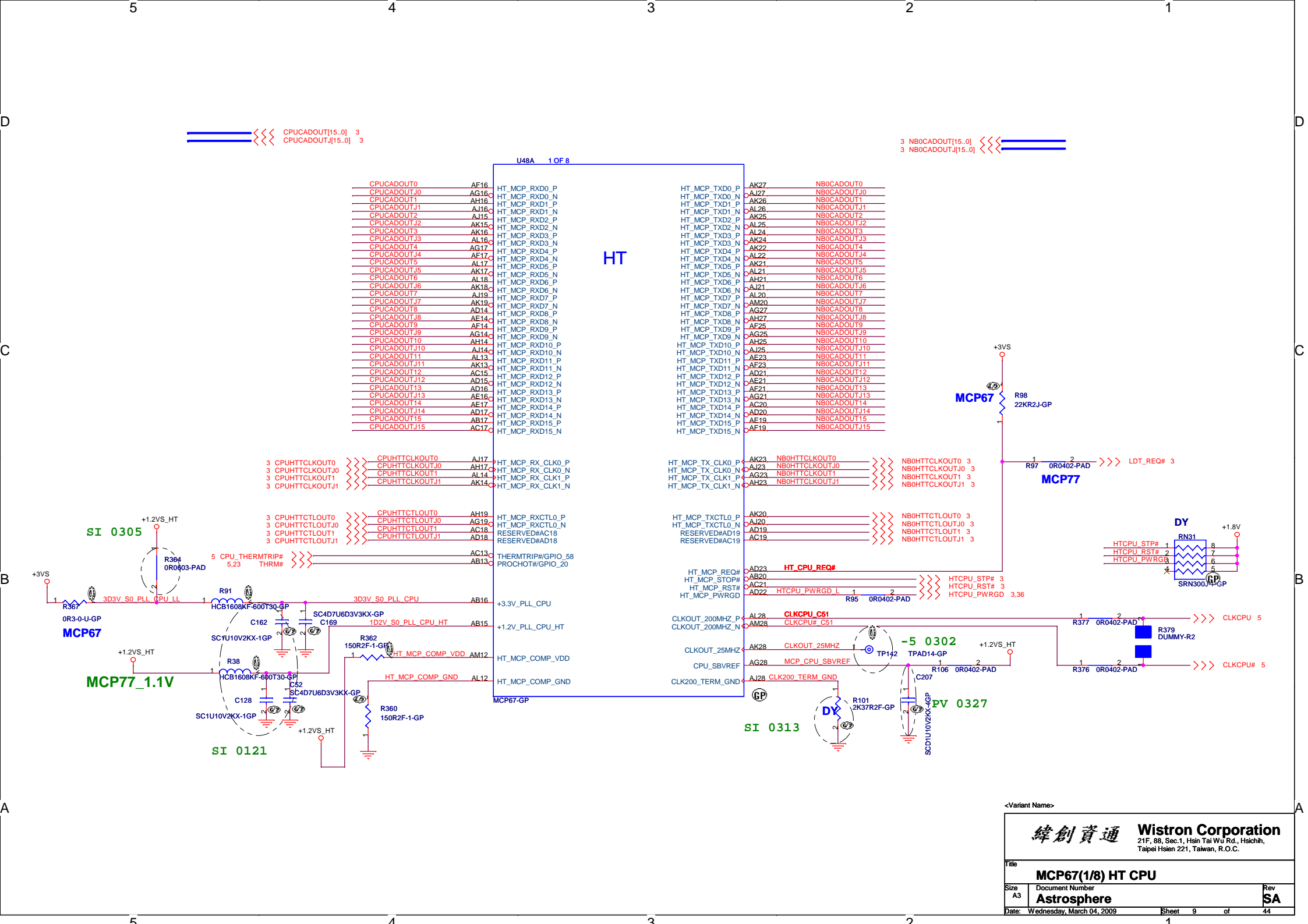

D

D

C

C

B

B

A

A

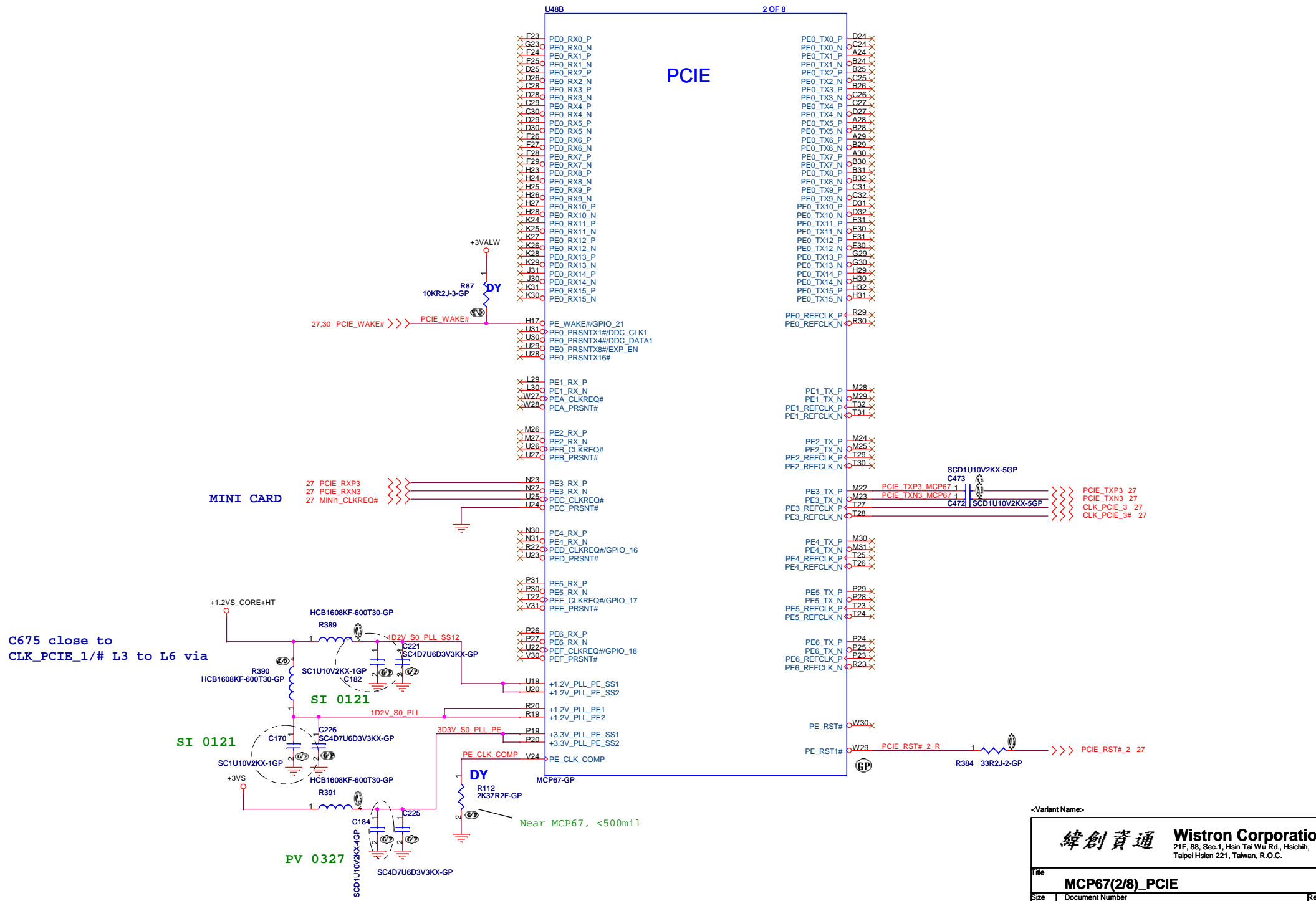

C675 close to CLK_PCIE_1/# L3 to L6 via

MINI CARD

SI 0121

PV 0327

Near MCP67, <500mil

<Variant Name>

緯創資通 **Wistron Corporation**
 21F, 88, Sec.1, Hsin Tai Wu Rd., Hsichih, Taipei Hsien 221, Taiwan, R.O.C.

Title MCP67(2/8)_PCIE		
Size A3	Document Number Astrosphere	Rev SA
Date: Wednesday, March 04, 2009	Sheet 10	of 44

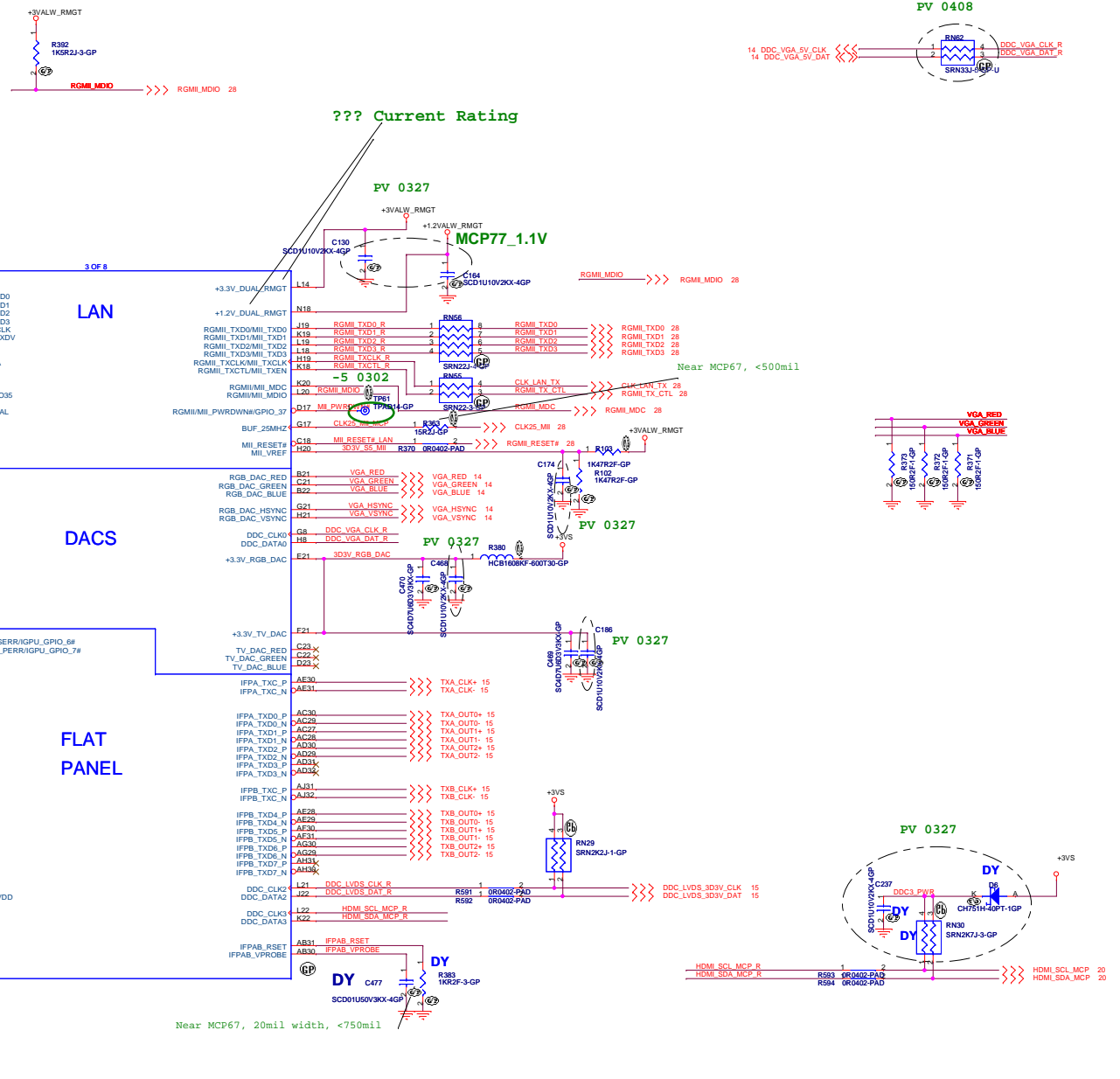
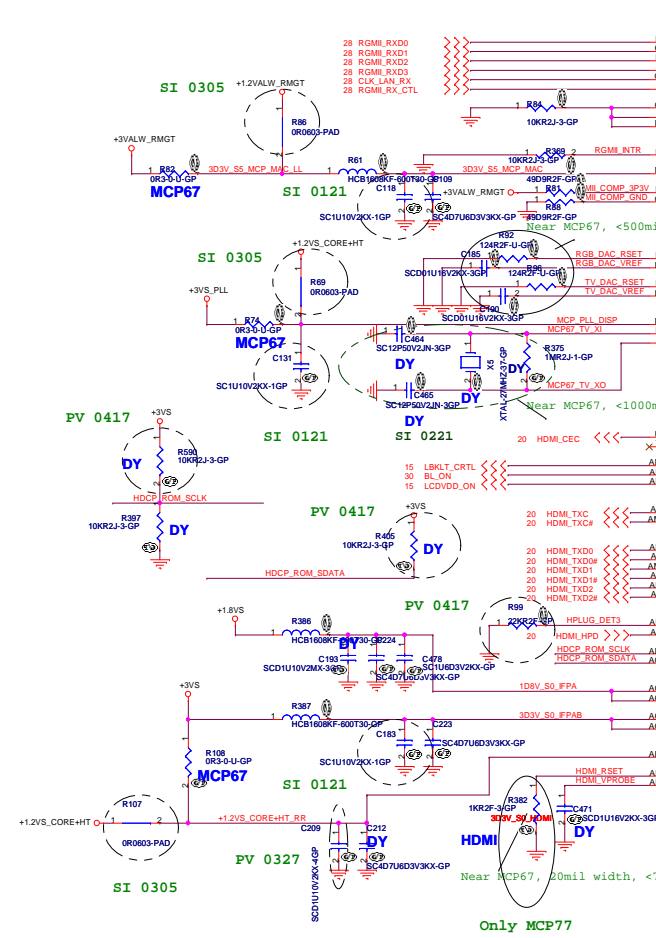
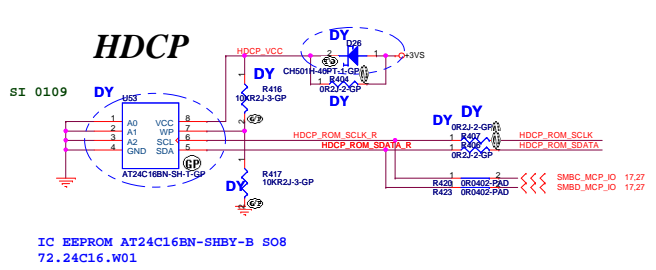

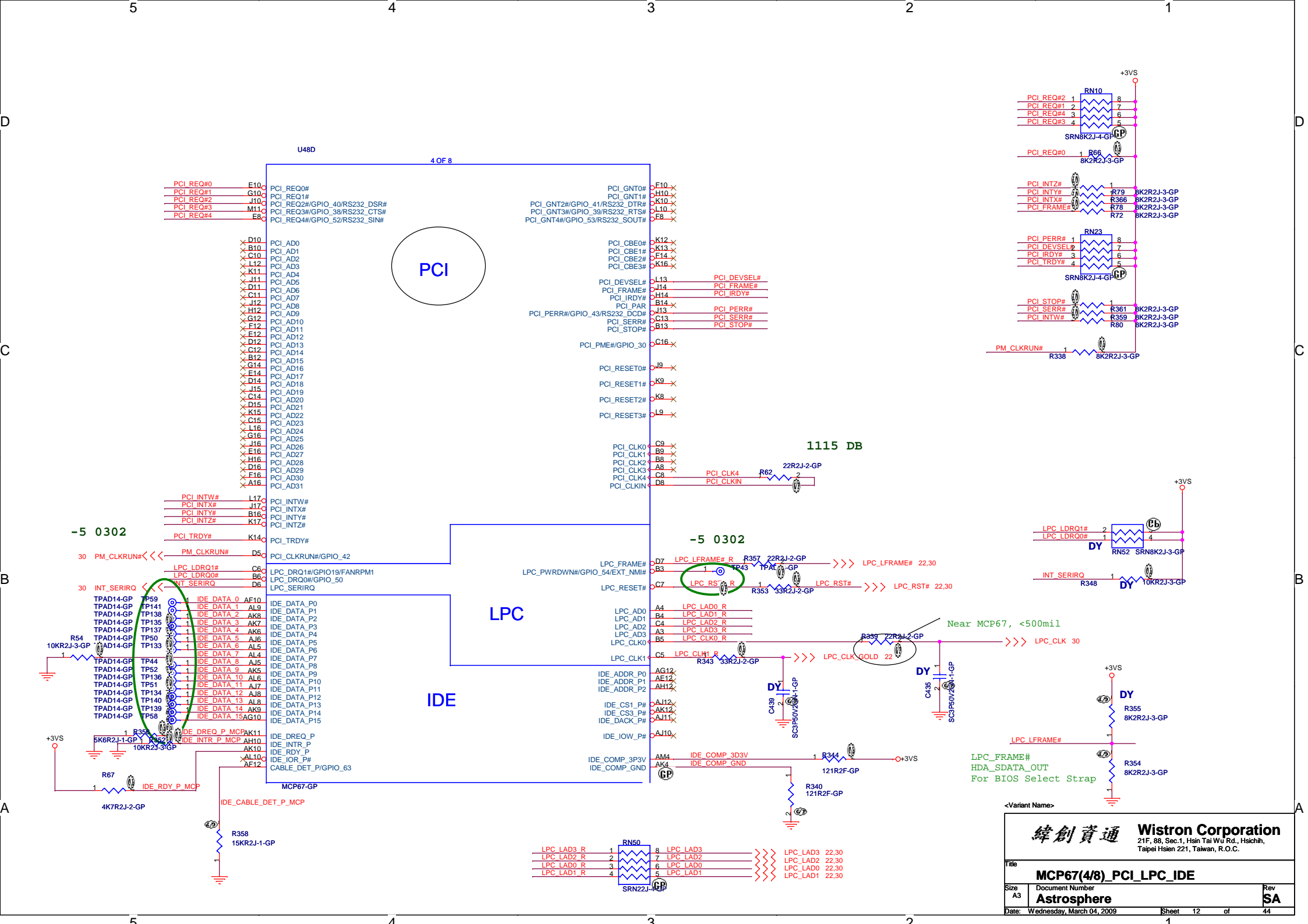

<Variant Name>

緯創資通 Wistron Corporation
21F, 88, Sec.1, Hsin Tai Wu Rd., Hsichih,
Taipei Hsien 221, Taiwan, R.O.C.

MCP67(4/8) PCI LPC IDE

Size A3 Document Number
Astrophere Rev SA

Date: Wednesday, March 04, 2009 Sheet 12 of 44

If no 1394
Port 0 for NVidia Win-debug

place near MCP67

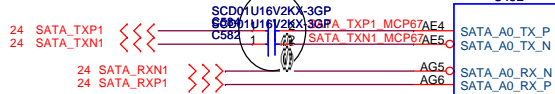

place near MCP67

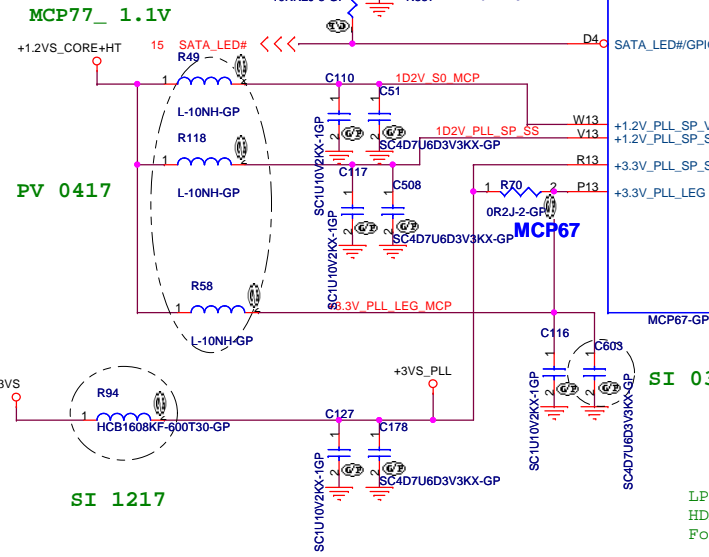
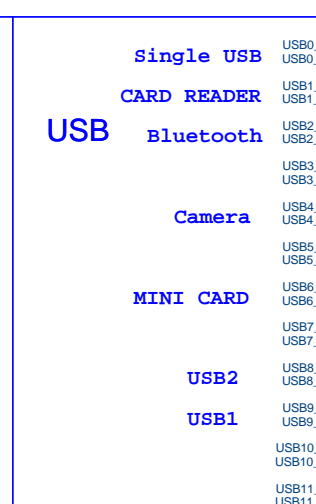
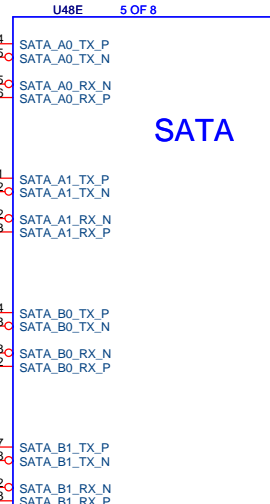

Only MCP77
1.1K on MCP67

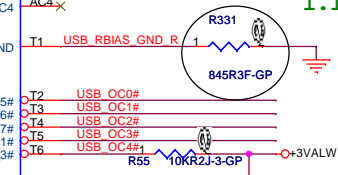

SI 0317

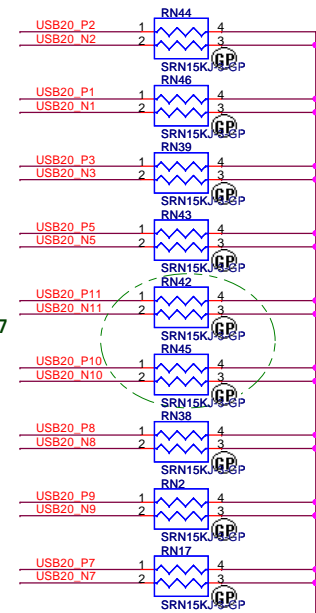

PV 0327

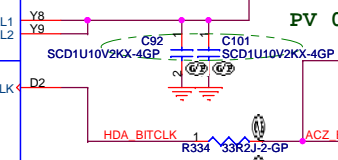

Check this NEW_OC#

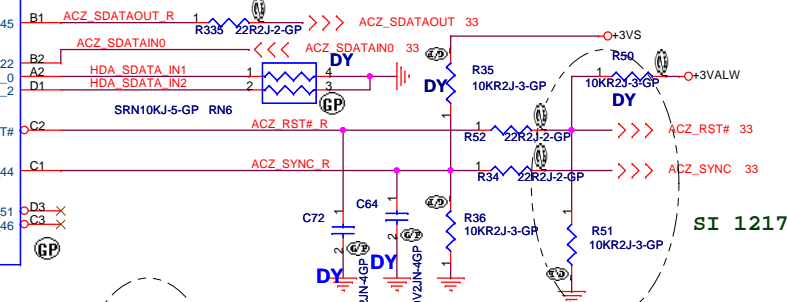

SI 1217

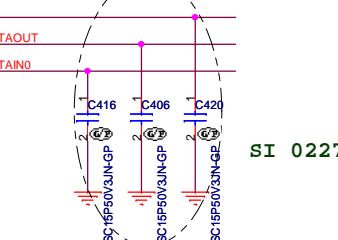

SI 0227

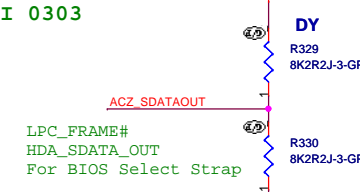

LPC_FRAME#
HDA_SDATA_OUT
For BIOS Select Strap

<Variant Name>

緯創資通 **Wistron Corporation**
21F, 88, Sec.1, Hsin Tai Wu Rd., Hsichih,
Taipei Hsien 221, Taiwan, R.O.C.

Title		
MCP67(5/8)_SATA_USB_HDA		
Size	Document Number	Rev
A3	Asphere	SA
Date: Wednesday, March 04, 2009	Sheet 13	of 44

CRT I/F & CONNECTOR

Layout Note:
Place these resistors
close to the CRT-out
connector

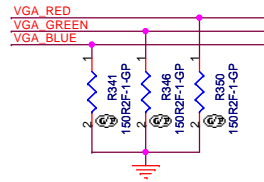
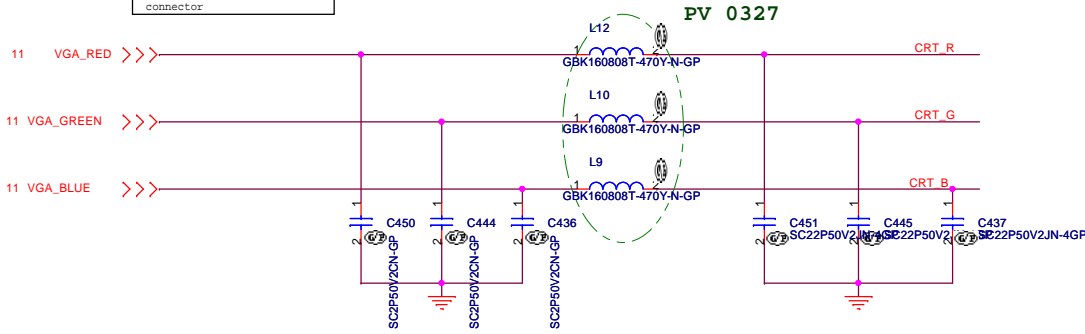

Layout Note:

* Must be a ground return path between this ground and the ground on the VGA connector.
Pi-filter & 150 Ohm pull-down resistors should be as close as to CRT CONN. RGB will hit 75 Ohm first, pi-filter, then CRT CONN.

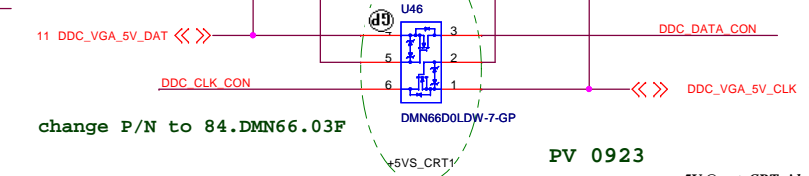
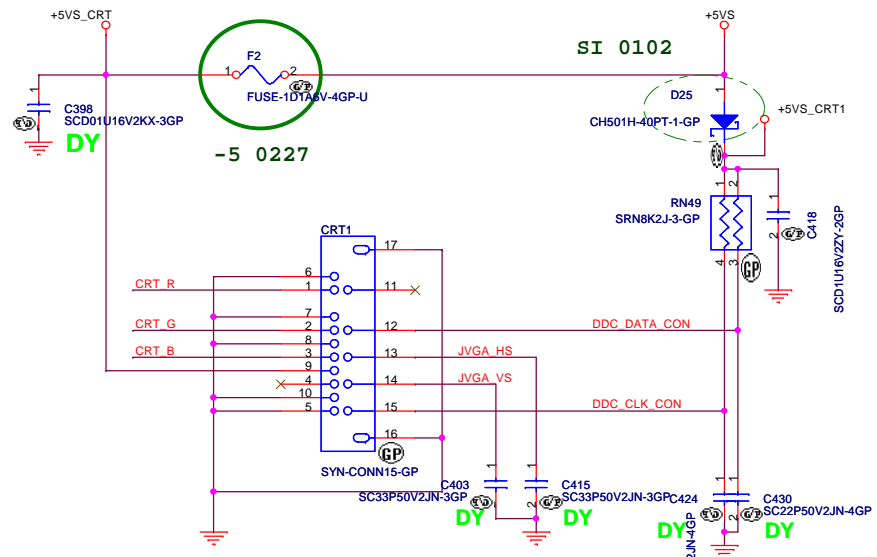
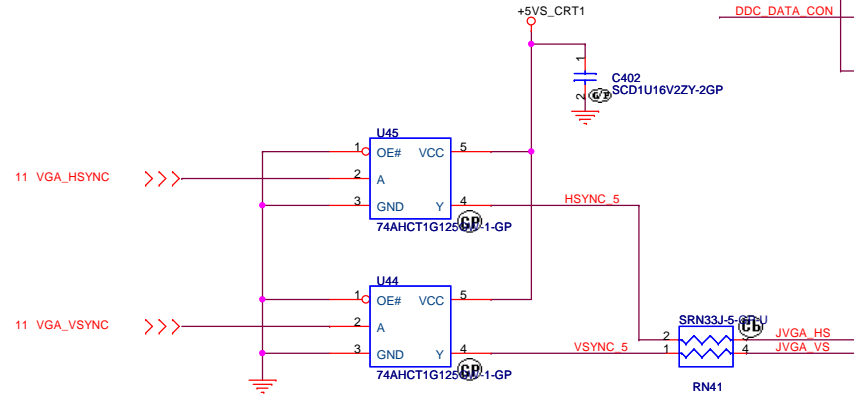
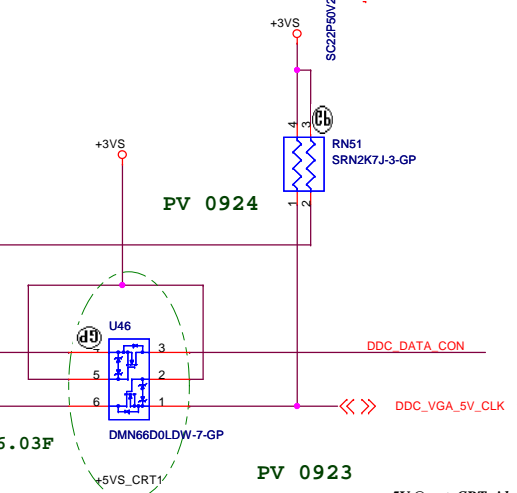
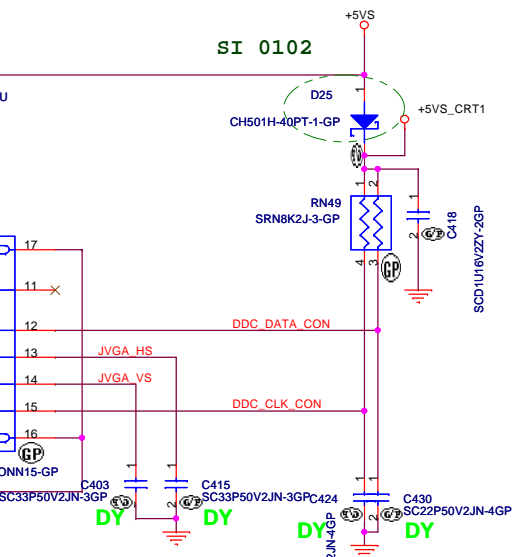
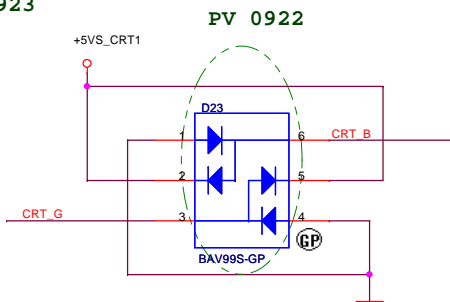
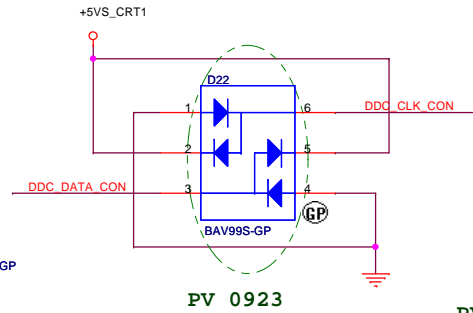
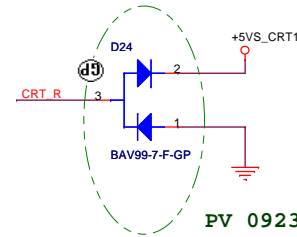

<Variant Name>

緯創資通 Wistron Corporation
21F, 88, Sec.1, Hsin Tai Wu Rd., Hsichih,
Taipei Hsien 221, Taiwan, R.O.C.

Title: **CRT/TV CONNECTOR**

Size: A3	Document Number: Astrosphere	Rev: SA
Date: Wednesday, March 04, 2009	Sheet: 14 of 44	

LCD / INVERTER INTERFACE/CAMERA

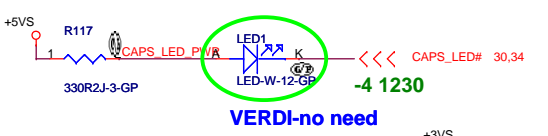
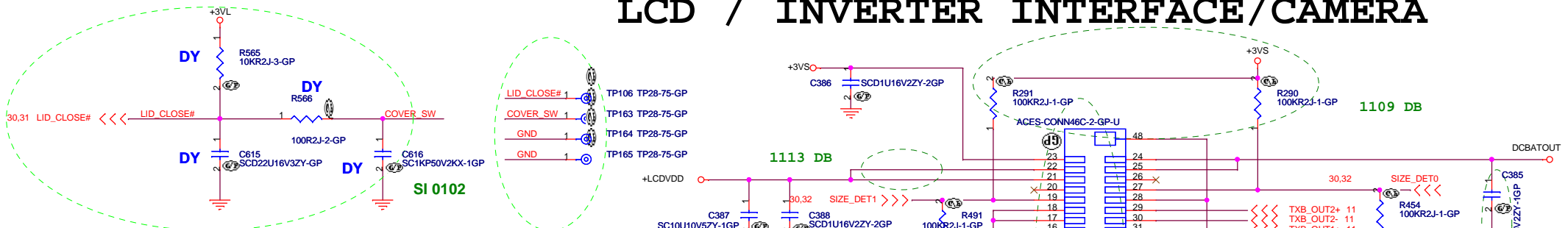

White LED:
v Lite-On 83.00191.D70
Everlight 83.19217.F70

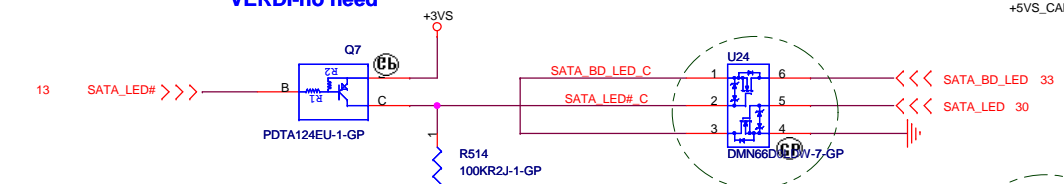

change P/N to 84.DMN66.03F

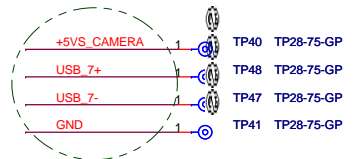
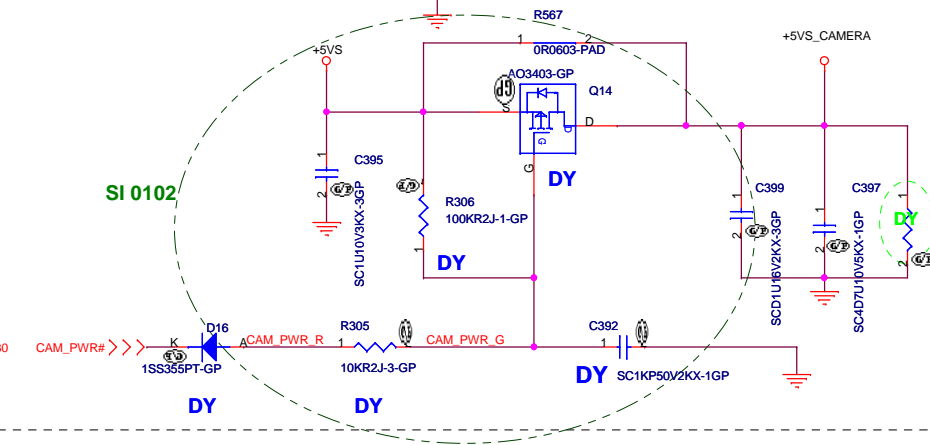

Close to LVDS1

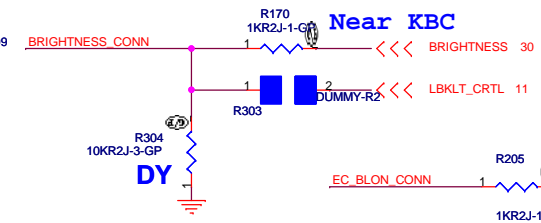

Near KBC

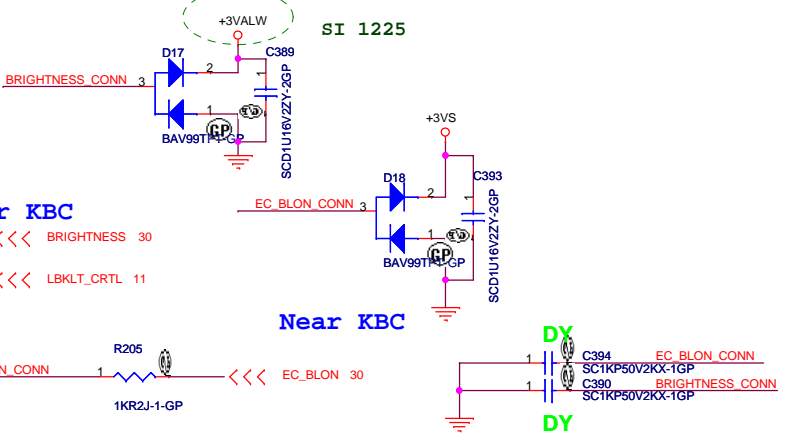

Near KBC

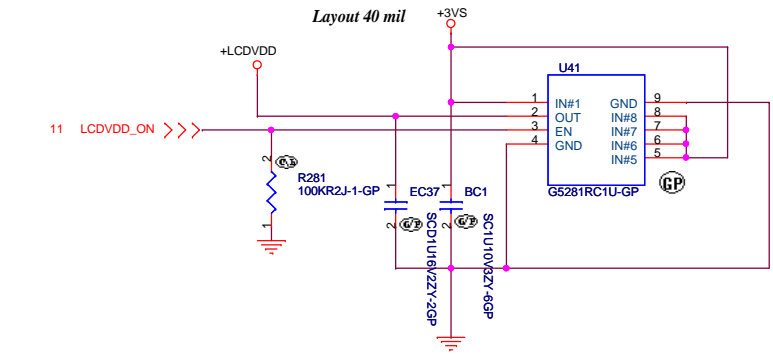

Layout 40 mil

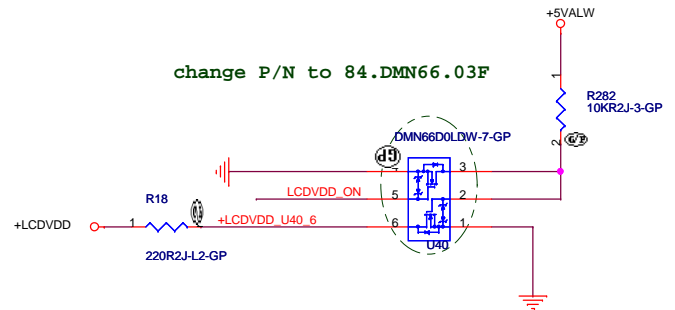

change P/N to 84.DMN66.03F

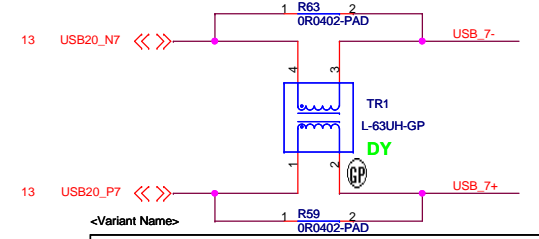

緯創資通 Wistron Corporation
21F, 88, Sec.1, Hsin Tai Wu Rd., Hsichih,
Taipei Hsien 221, Taiwan, R.O.C.

Title			LCD/Inverter Connector		
Size	Document Number				Rev
Custom			Astrosphere		SA
Date:	Wednesday, March 04, 2009	Sheet	15	of	44

A

B

C

D

E

4

4

3

3

2

2

1

1

<Variant Name>

緯創資通 **Wistron Corporation**
 21F, 88, Sec.1, Hsin Tai Wu Rd., Hsichih,
 Taipei Hsien 221, Taiwan, R.O.C.

Title **Board to board conn/ Docking**

Size A3	Document Number Astrosphere	Rev SA
------------	---------------------------------------	------------------

Date: Wednesday, March 04, 2009 Sheet 16 of 44

A

B

C

D

E

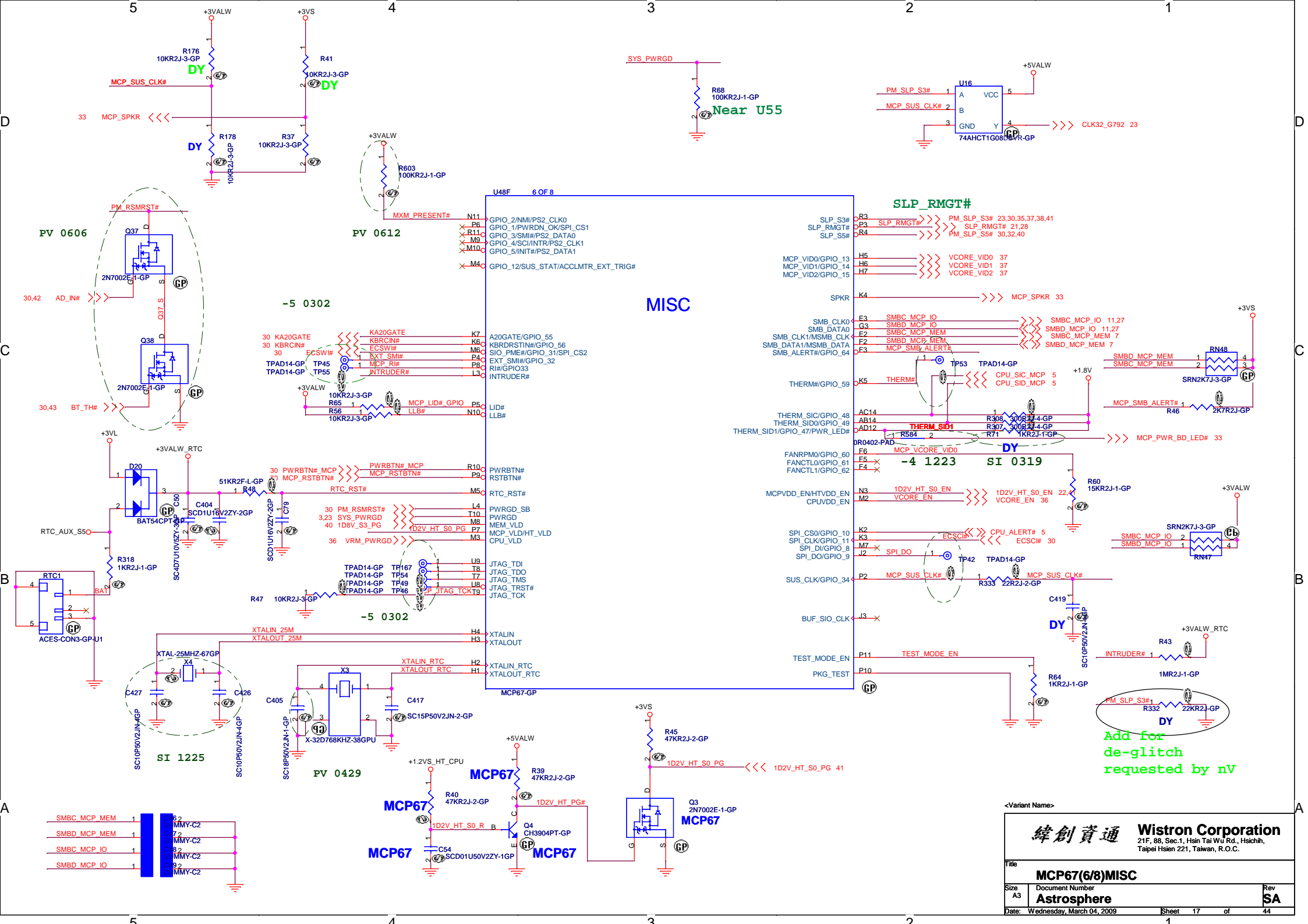

R68
 100KR2J-1-GP
 Near U55

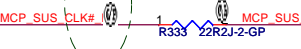
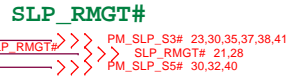
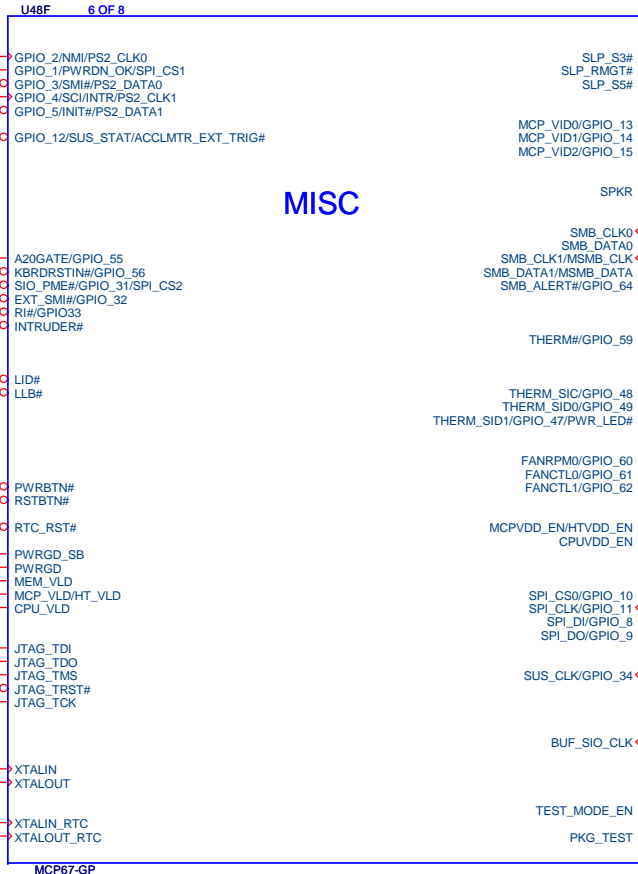
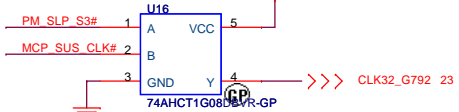

Add for
 de-gitch
 requested by nV

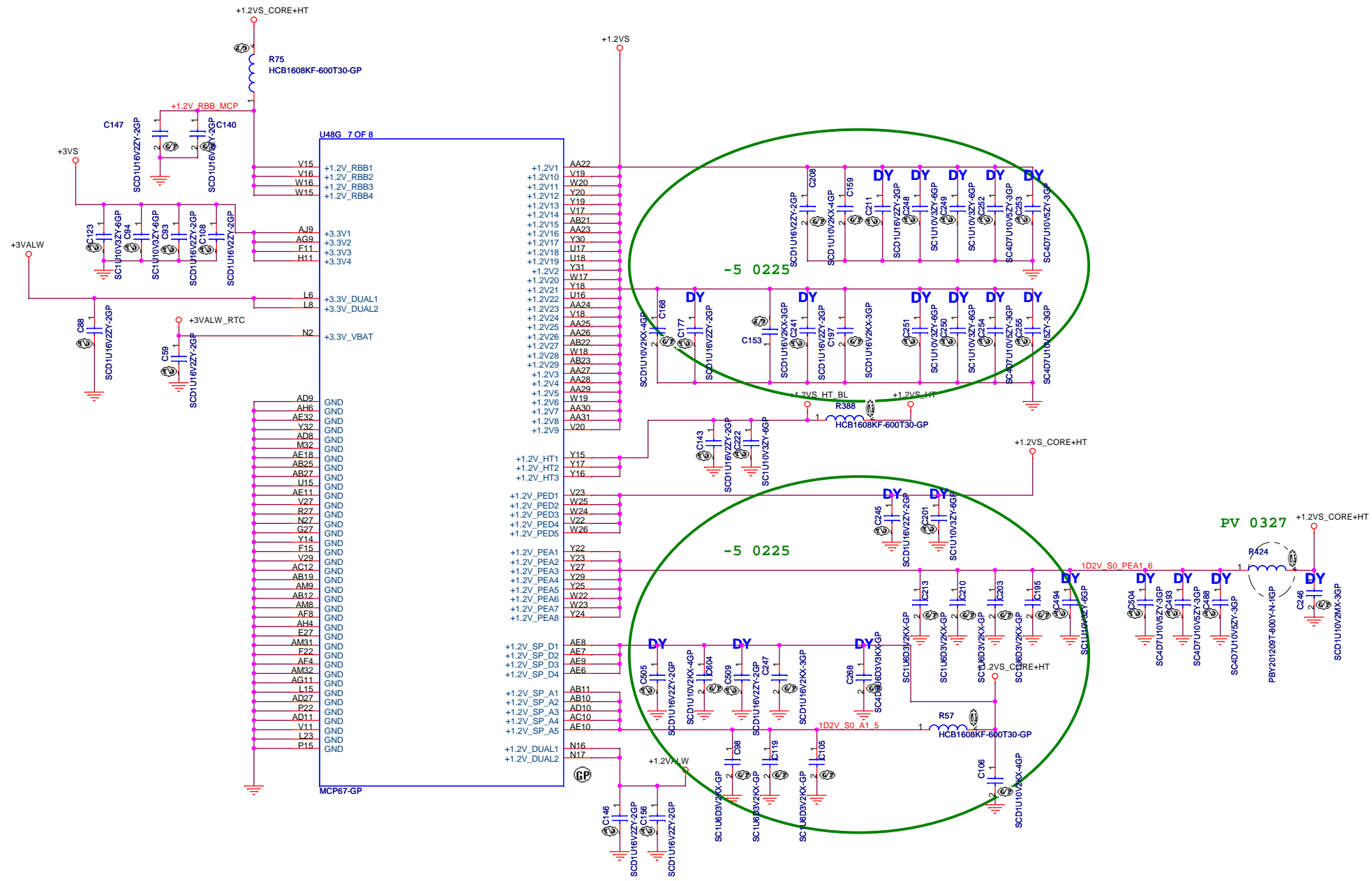

<Variant Name>

緯創資通 Wistron Corporation
 21F, 88, Sec.1, Hsin Tai Wu Rd., Hsichih,
 Taipei Hsien 221, Taiwan, R.O.C.

Title: **MCP67(7/8)_POWER**

Size: A3 Document Number: **Astrosphere** Rev: SA

Date: Wednesday, March 04, 2009 Sheet 18 of 44

U48H_8 OF 8

AB9	RESERVED#AB9	RESERVED#AC7	AC7
AC6	RESERVED#AC6	RESERVED#AB8	AB8
AC8	RESERVED#AC8	RESERVED#V9	V9
AA8	RESERVED#AA8	RESERVED#W11	W11
AD3	RESERVED#AD3	RESERVED#W10	W10
AD4	RESERVED#AD4	RESERVED#W9	W9
AA9	RESERVED#AA9	RESERVED#Y11	Y11
AC5	RESERVED#AC5	RESERVED#Y10	Y10
AC9	RESERVED#AC9	RESERVED#AA11	AA11
		RESERVED#AA10	AA10

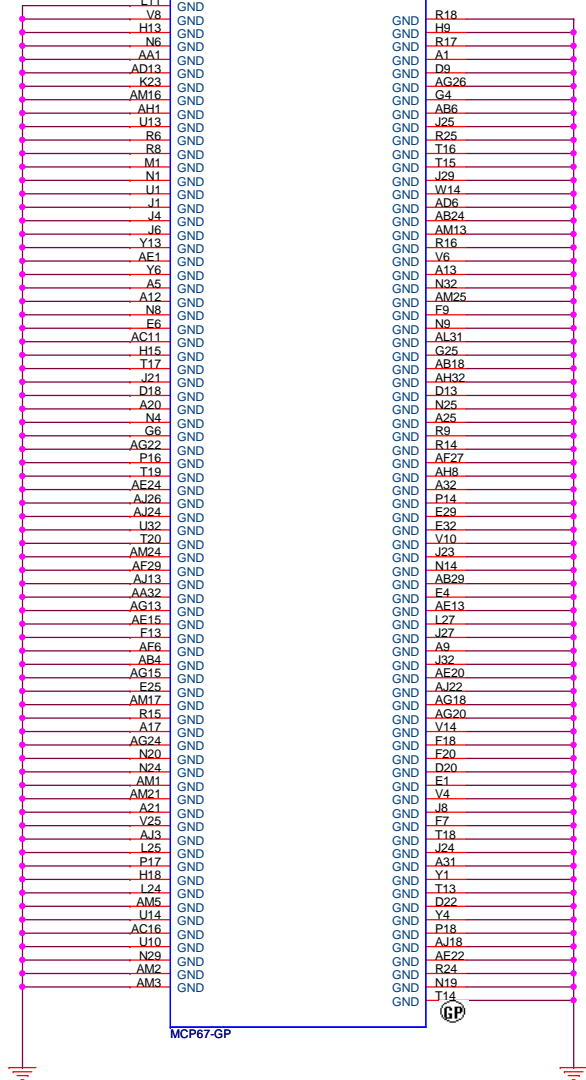

<Variant Name>

緯創資通		Wistron Corporation	
		21F, 88, Sec.1, Hsin Tai Wu Rd., Hsichih, Taipei Hsien 221, Taiwan, R.O.C.	
Title			
MCP67(8/8)_GND			
Size	Document Number	Rev	
A3	Astrosphere	SA	
Date: Wednesday, March 04, 2009		Sheet 19	of 44

HDMI Place near MCP67

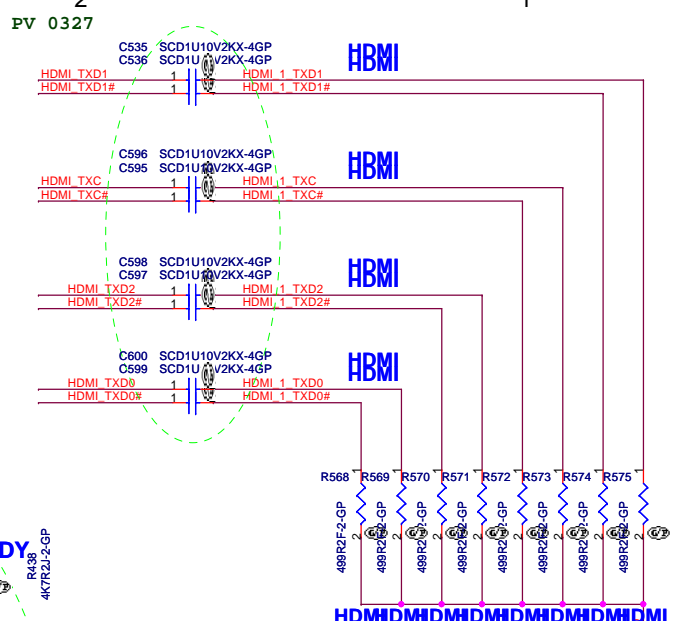
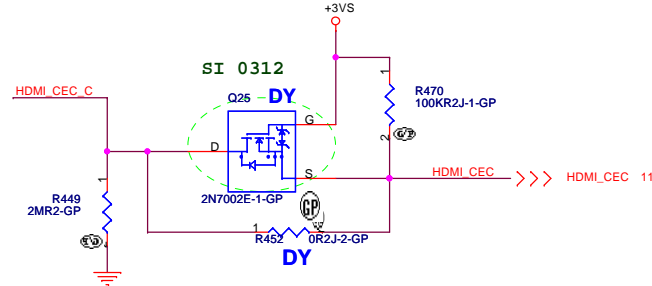
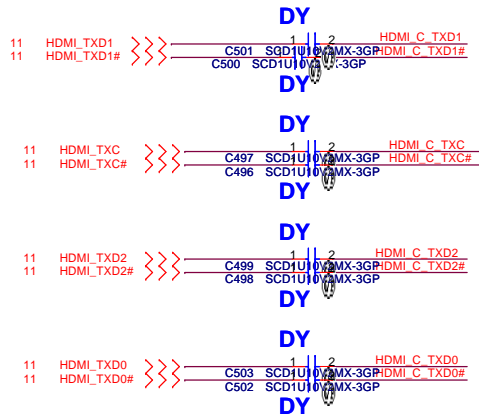

HDMI Connector

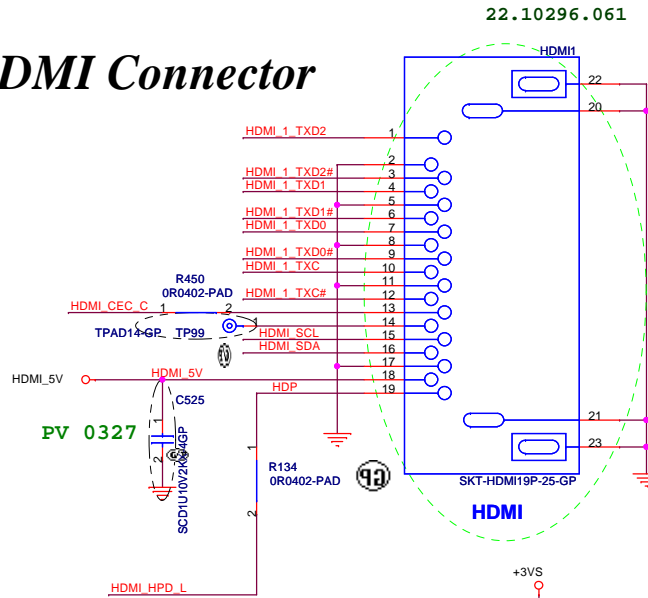

SI 0102

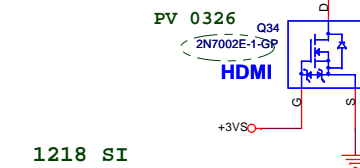
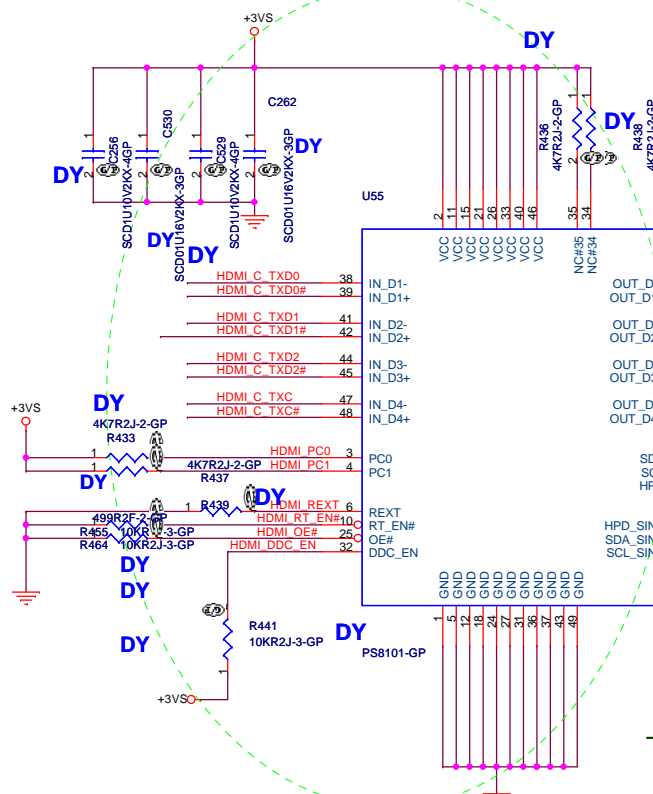

1218 SI

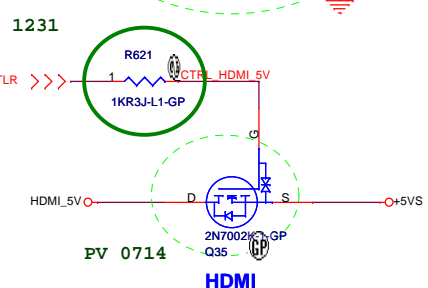
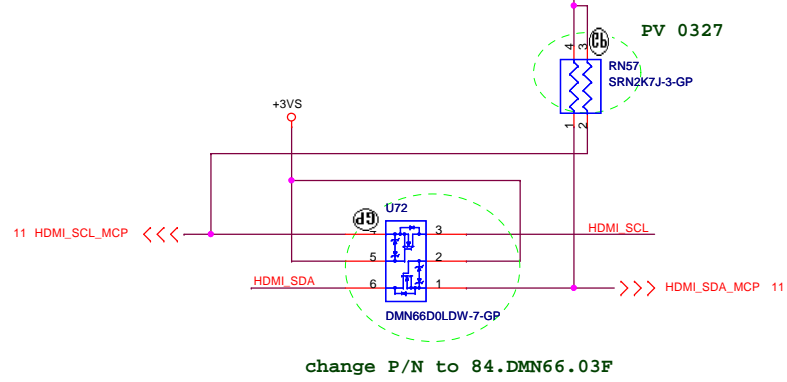
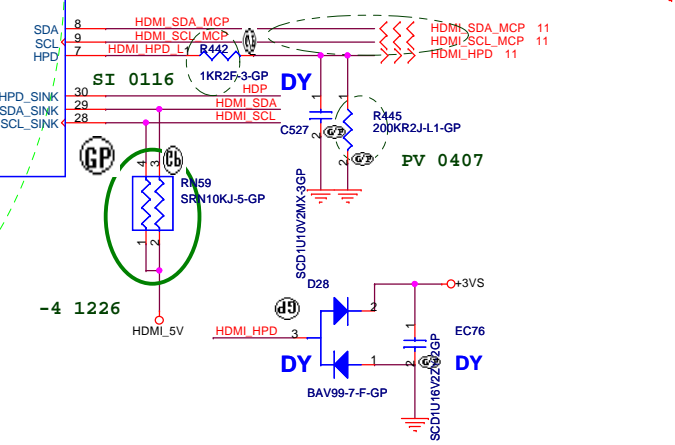

~Variant Name~
緯創資通 Wistron Corporation
 21F, 88, Sec.1, Hsin Tai Wu Rd., Hsichih, Taipei Hsien 221, Taiwan, R.O.C.
 Title: **HDMI**
 Size: A3
 Document Number: **Astrosphere**
 Date: Wednesday, March 04, 2009
 Sheet 20 of 44
 Rev: **SA**

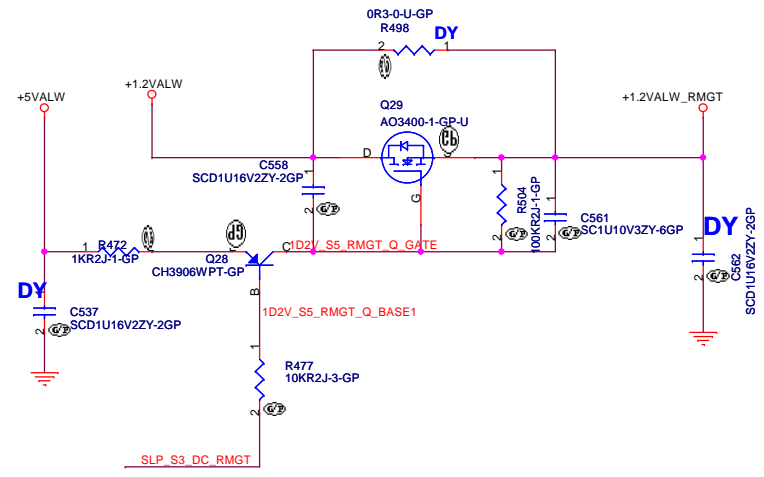
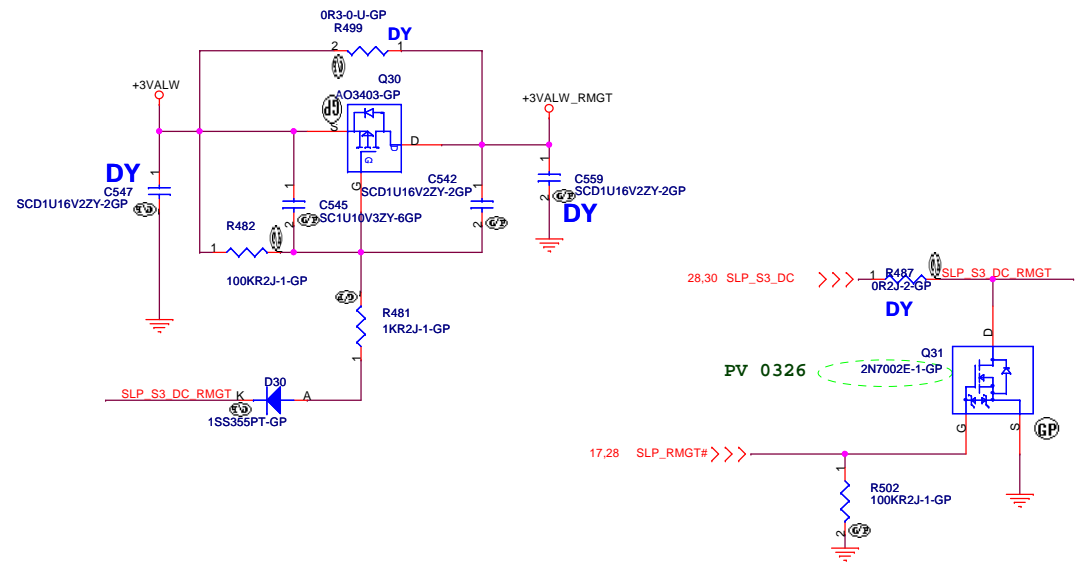

<Variant Name>

緯創資通		Wistron Corporation	
		21F, 88, Sec.1, Hsin Tai Wu Rd., Hsichih, Taipei Hsien 221, Taiwan, R.O.C.	
Title			
Size A3	Document Number Astrosphere	Rev SA	
Date: Wednesday, March 04, 2009		Sheet 21	of 44

MCP67

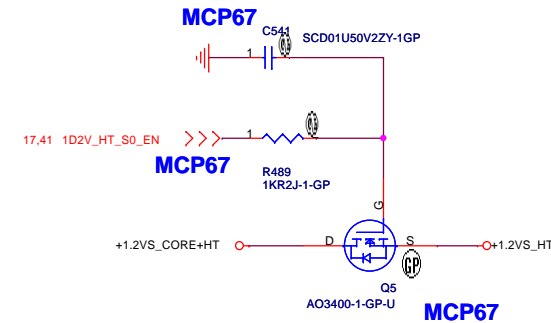

MCP77

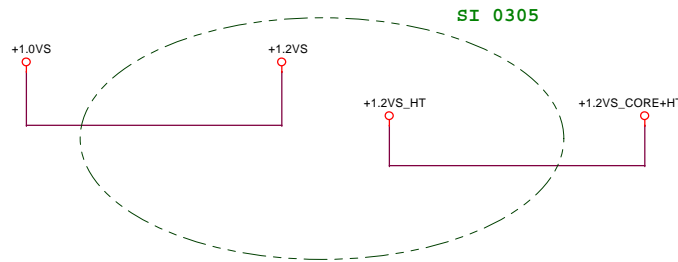

TOP VIEW

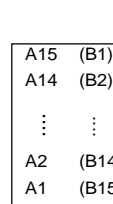

(BOTTOM VIEW)

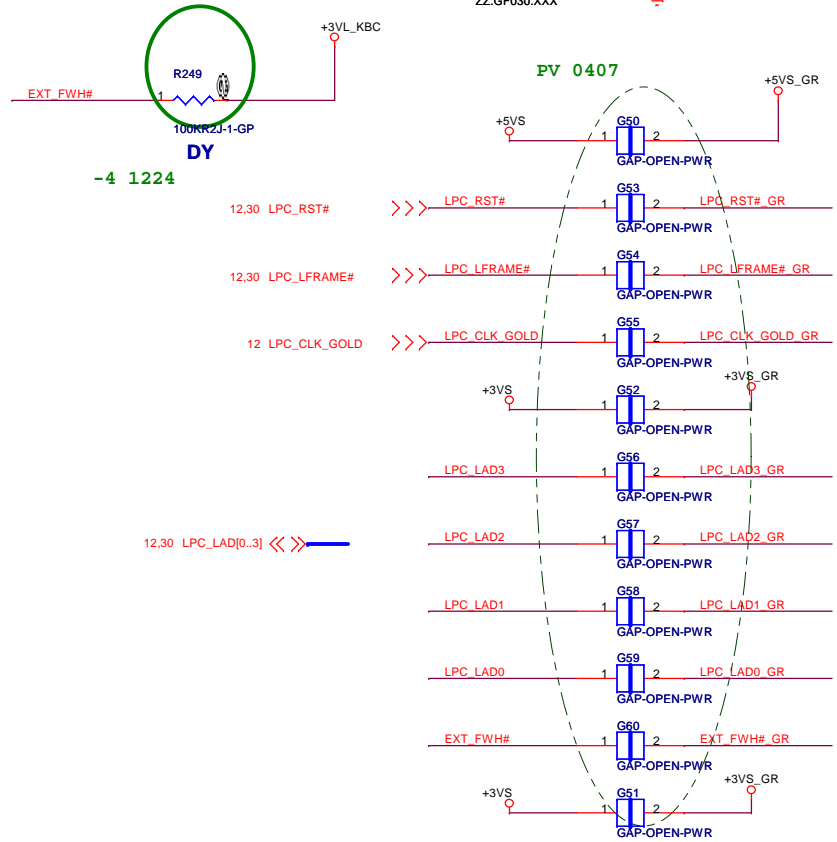

GOLDEN FINGER FOR DEBUG BOARD

Put near board edge

<Variant Name>

		Wistron Corporation 21F, 88, Sec.1, Hsin Tai Wu Rd., Hsichih, Taipei Hsien 221, Taiwan, R.O.C.	
Title			
POWER PATH			
Size	Document Number	Rev	
A3	Astrosphere	SA	
Date: Wednesday, March 04, 2009		Sheet	22 of 44

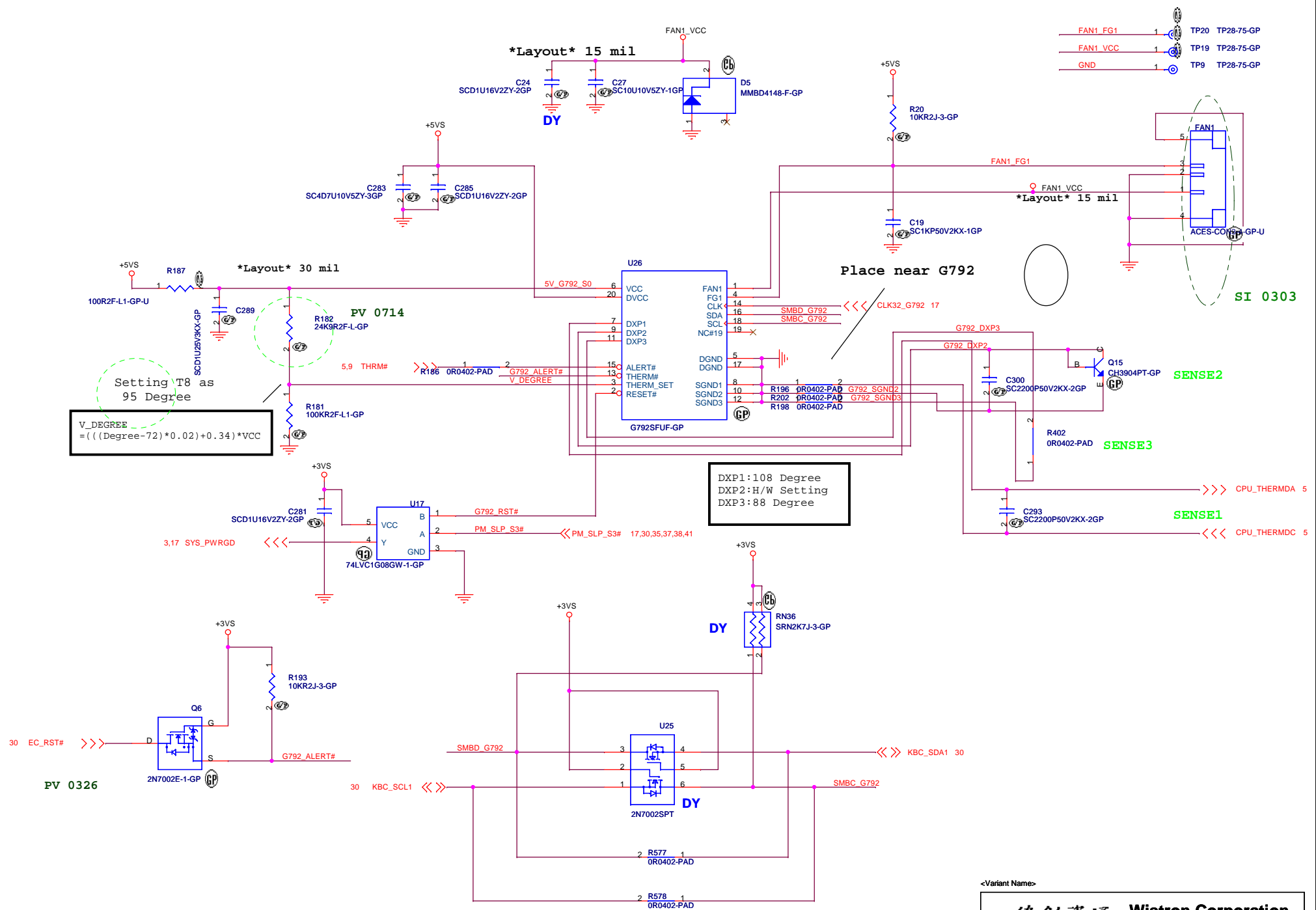

Setting T8 as 95 Degree

$$V_DEGREE = (((Degree - 72) * 0.02) + 0.34) * VCC$$

DXP1:108 Degree
DXP2:H/W Setting
DXP3:88 Degree

<Variant Name>

緯創資通 Wistron Corporation
21F, 88, Sec.1, Hsin Tai Wu Rd., Hsichih, Taipei Hsien 221, Taiwan, R.O.C.

Title: **Thermal/Fan Controller**

Size Custom	Document Number	Rev SA
Date: Wednesday, March 04, 2009		Sheet 23 of 44

Close to USB1

1115 DB SATA HD Connector

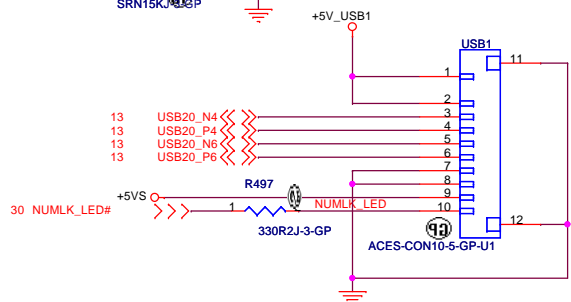
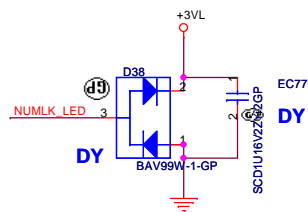
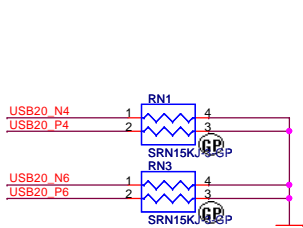
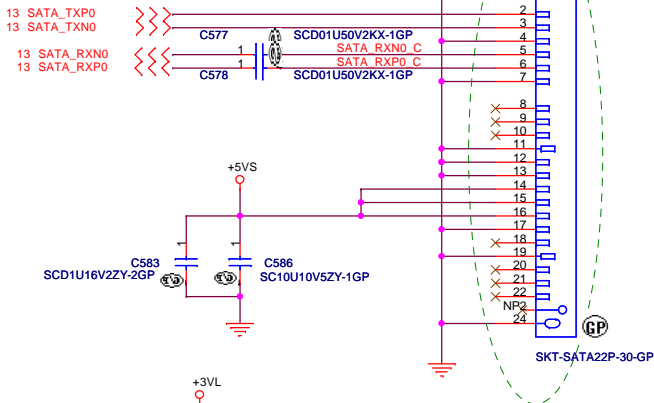
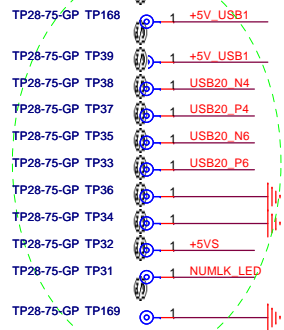

USB PORT

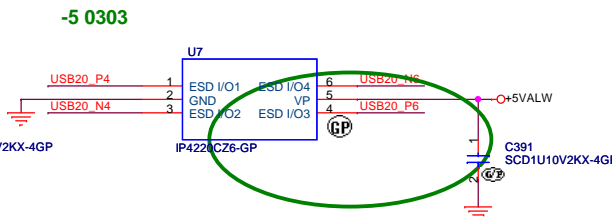
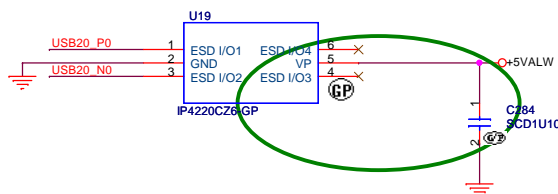
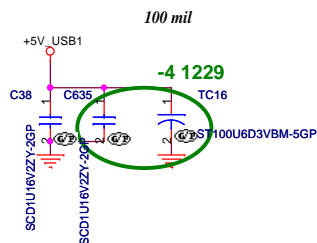
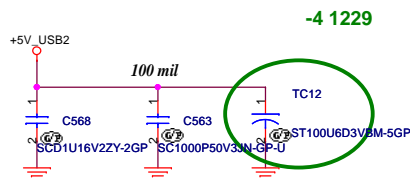

ODD Connector

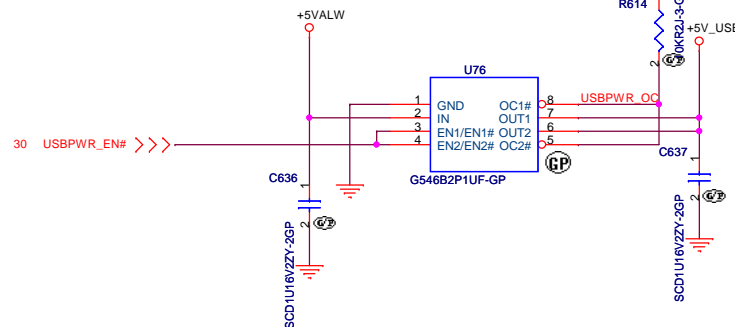
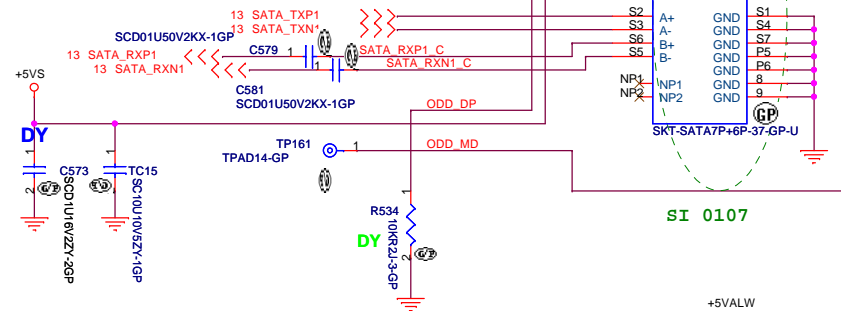

-4 1226

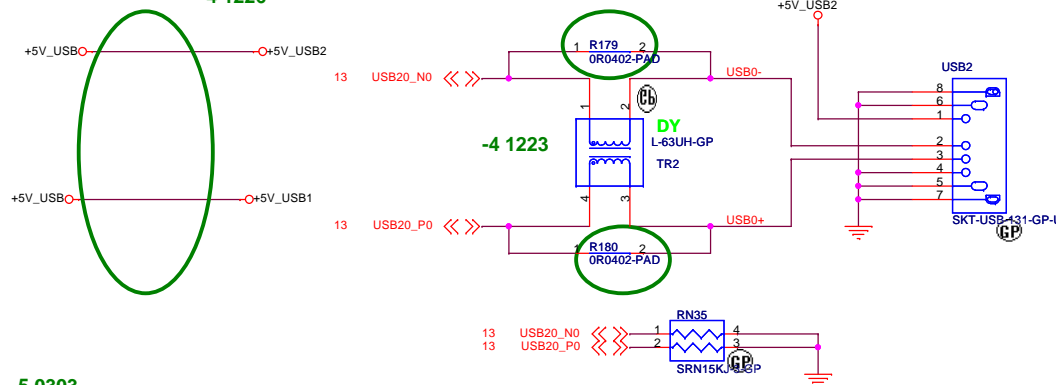

-5 0303

<Variant Name>

緯創資通 Wistron Corporation
 21F, 88, Sec.1, Hsin Tai Wu Rd., Hsichih, Taipei Hsien 221, Taiwan, R.O.C.

Title	HD/CDROM		Rev
Size	Document Number	SA	
A3	Astrosphere		SA
Date:	Wednesday, March 04, 2009	Sheet	24 of 44

5158E vendor suggest use 5.6pF or use 48MHz directly by Clock gne.

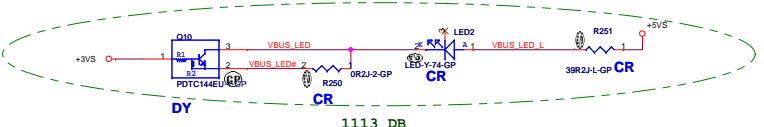
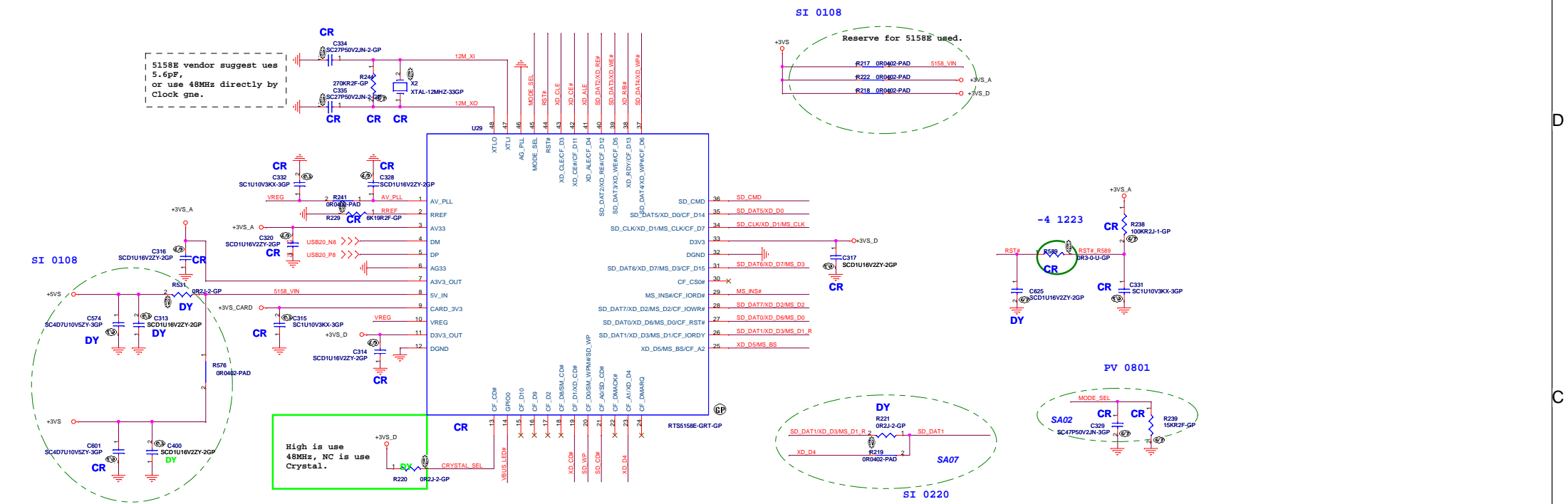

4 IN1 CARD-READER (SD/SD IO/MMC/MMC4.0/MS/MS PRO/XD)

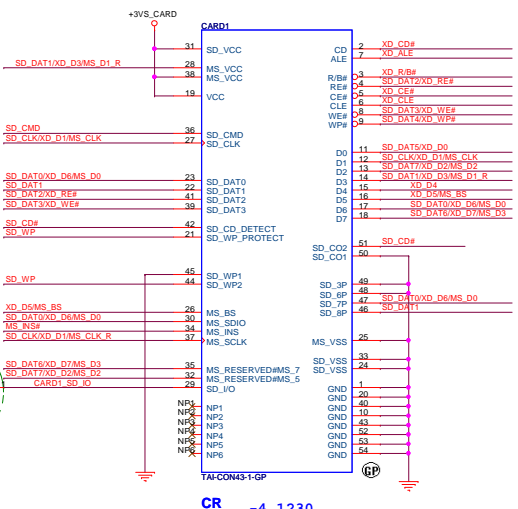
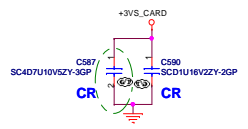
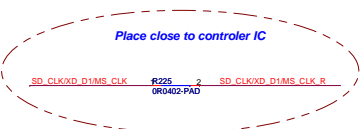

A

B

C

D

E

4

4

3

3

2

2

1

1

<Variant Name>

緯創資通

Wistron Corporation
21F, 88, Sec.1, Hsin Tai Wu Rd., Hsichih,
Taipei Hsien 221, Taiwan, R.O.C.

Title

R5C832/IEEE1394/SD

Size
A3

Document Number

Astrosphere

Rev

SA

Date: Wednesday, March 04, 2009

Sheet 26 of 44

A

B

C

D

E

Mini Card Connector 1

Wireless Card

Change P/N to 62.10043.611

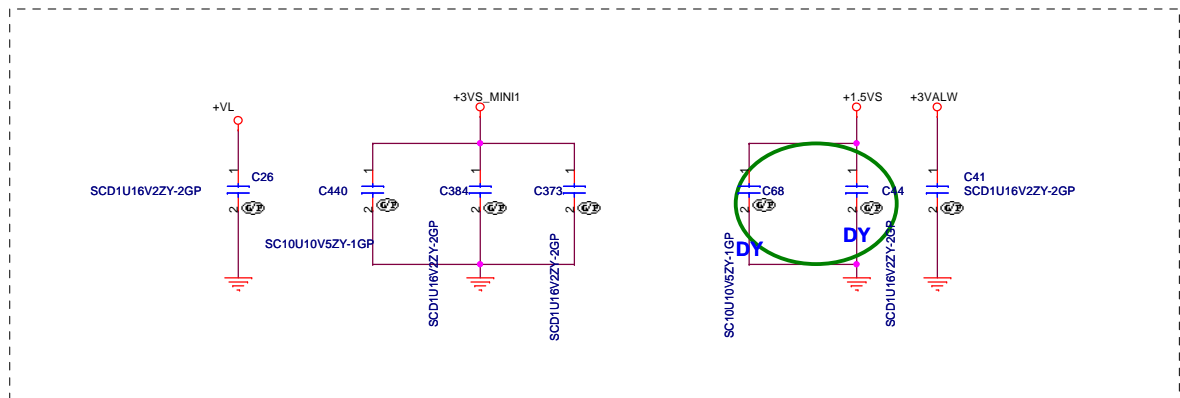
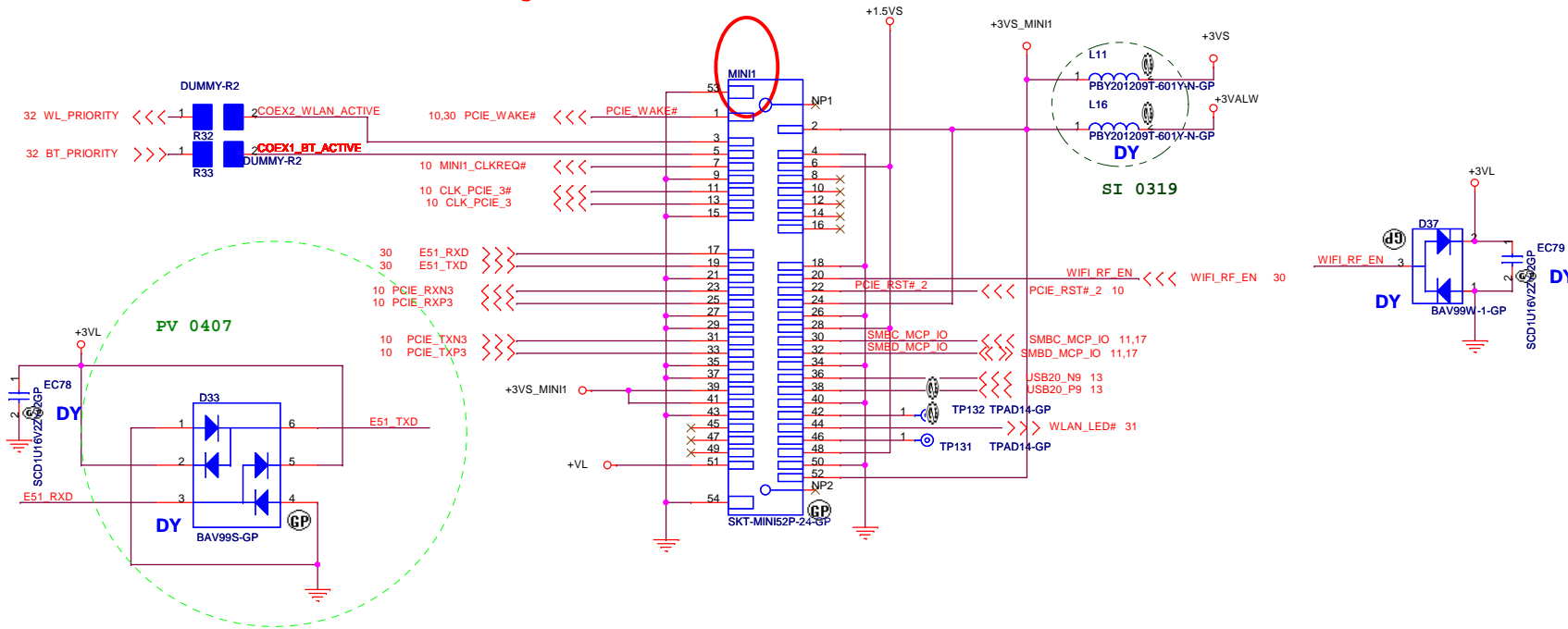

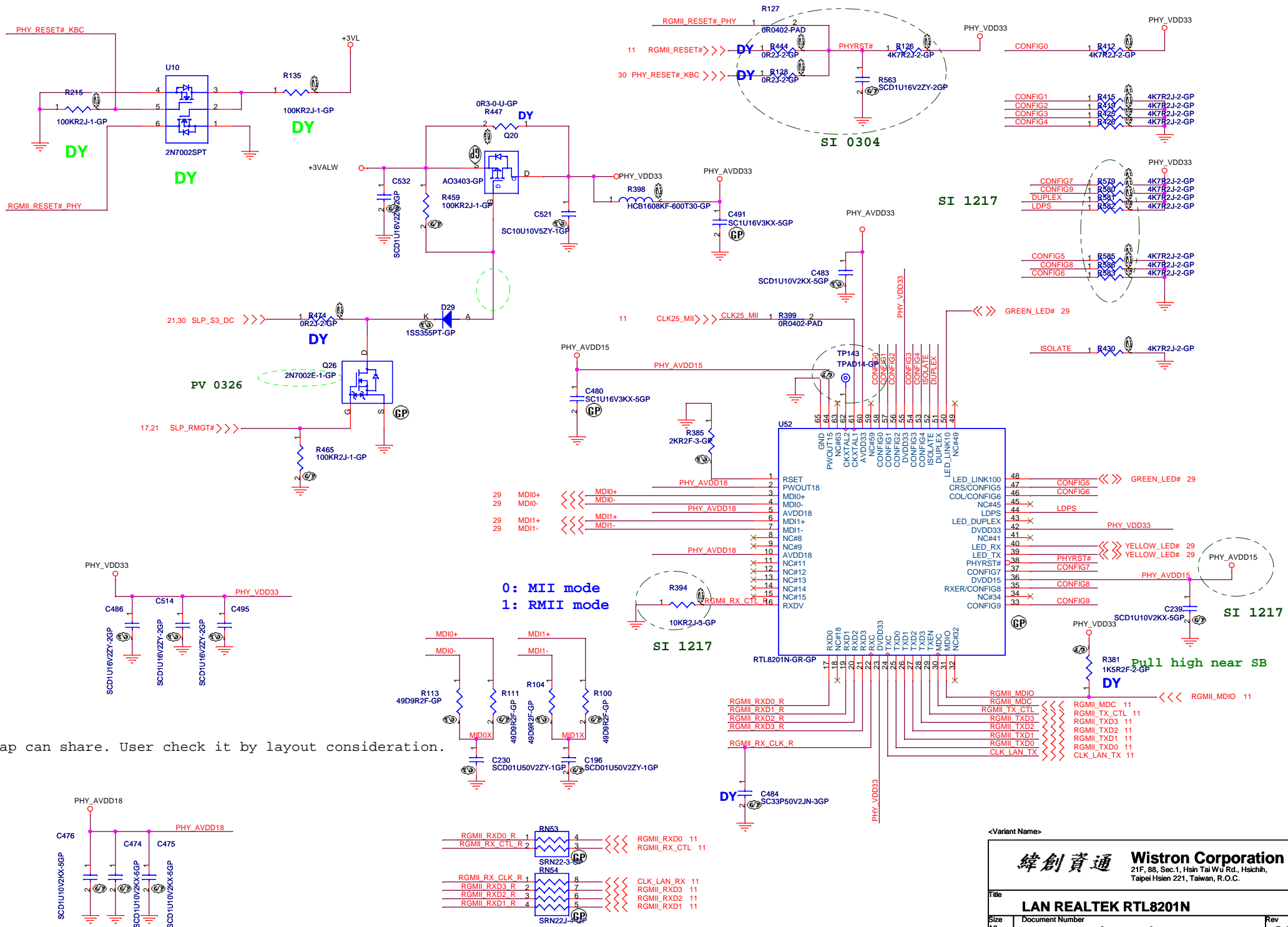

Bypass cap can share. User check it by layout consideration.

<Variant Name>

緯創資通 Wistron Corporation
21F, 88, Sec.1, Hsin Tai Wu Rd., Hsichih,
Taipei Hsien 221, Taiwan, R.O.C.

Title: **LAN REALTEK RTL8201N**

Size: A3	Document Number: Astrosphere	Rev: SA
Date: Wednesday, March 04, 2009	Sheet 28	of 44

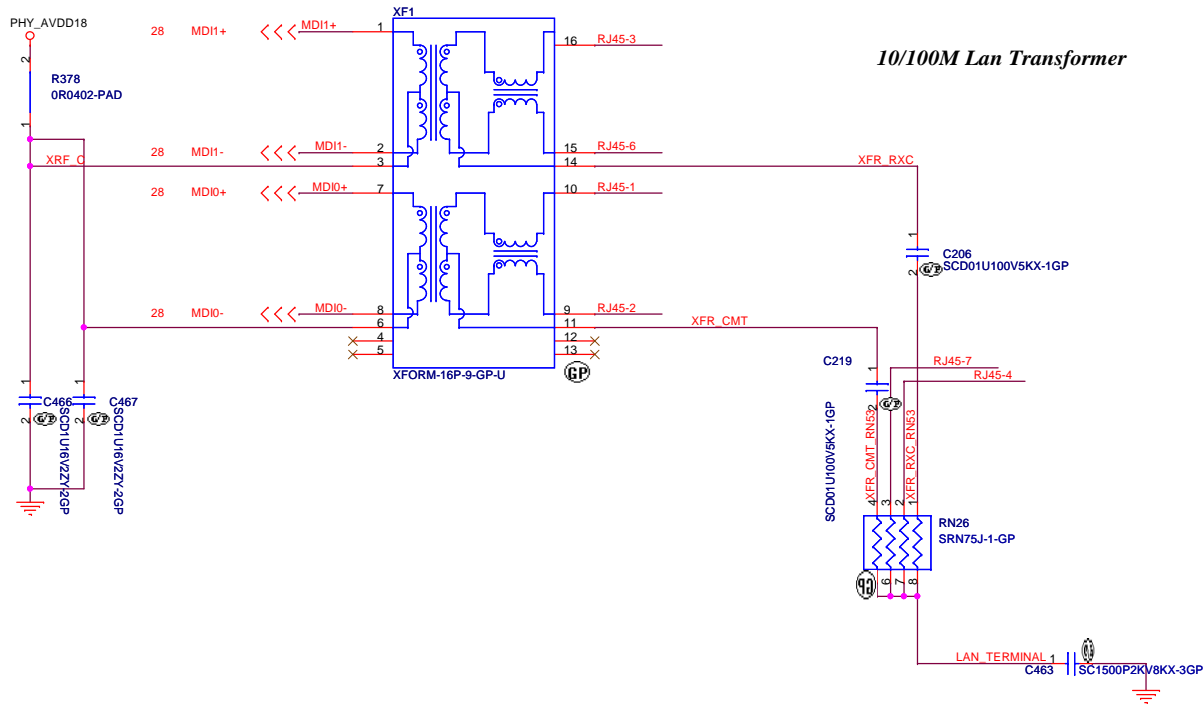

10/100M Lan Transformer

1. route on bottom as differential pairs.
2. Tx+/Tx- are pairs. Rx+/Rx- are pairs.
3. No vias, No 90 degree bends.
4. pairs must be equal lengths.
5. 6mil trace width, 12mil separation.
6. 36mil between pairs and any other trace.
7. Must not cross ground moat, except RJ-45 moat.

PIN A1 : GREEN
 PIN A3 : ORANGE
 PIN B2 : YELLOW

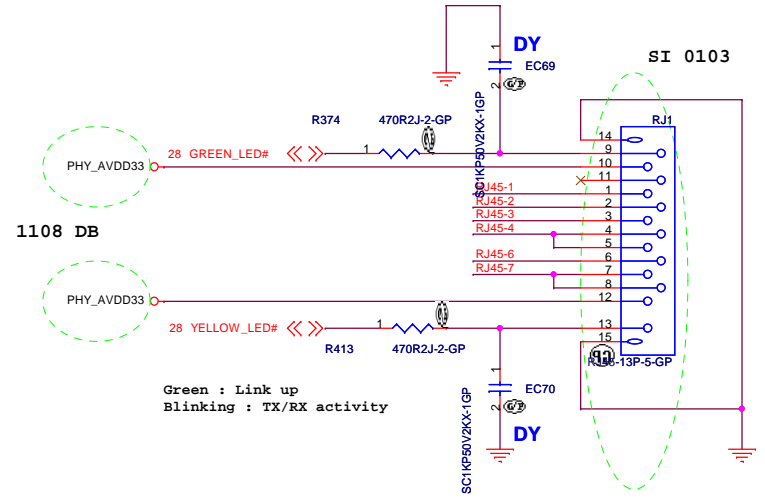

Remark:
 Add trace width to 20mils
 for RJ1 pin4, 5 and pin 7, 8.

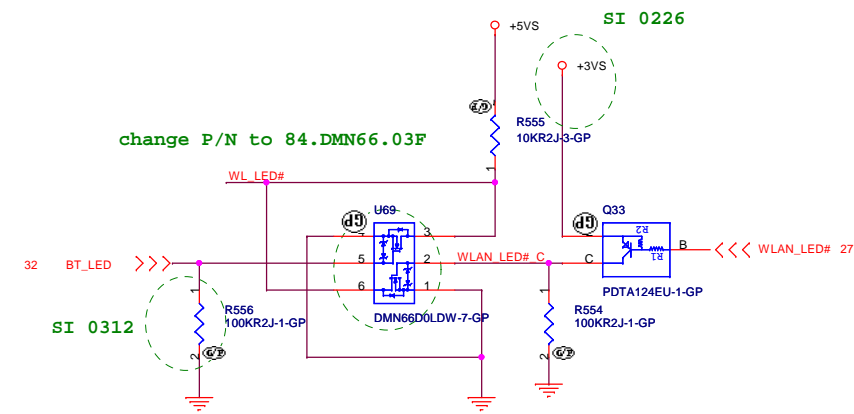
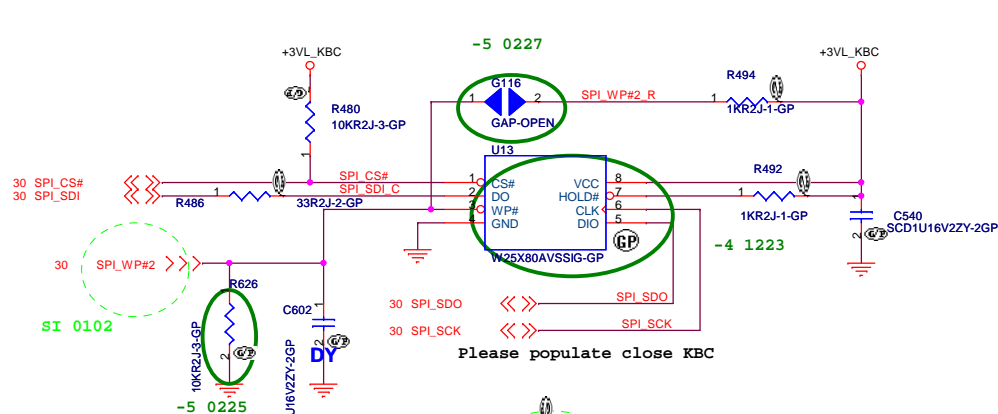

- TP28-75-GP TP26 <- +5VALW
- TP28-75-GP TP22 <- +5VS
- TP28-75-GP TP29 <- PWR_BD_LED#
- TP28-75-GP TP24 <- PWR_BT#
- TP28-75-GP TP30 <- WLAN_AMBER
- TP28-75-GP TP28 <- WLAN_WHITE#
- TP28-75-GP TP27 <- WLAN_BT#
- TP28-75-GP TP23 <- LID_CLOSE#
- TP28-75-GP TP25 <- +3VL
- TP28-75-GP TP21 <- GND
- TP28-75-GP TP170 <- GND

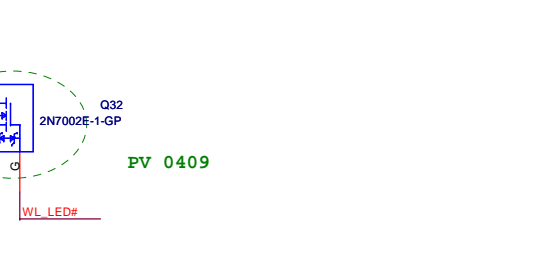
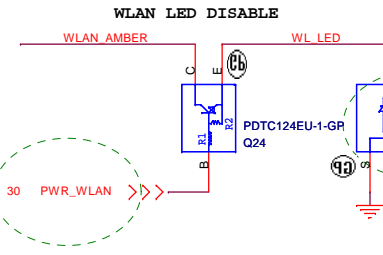
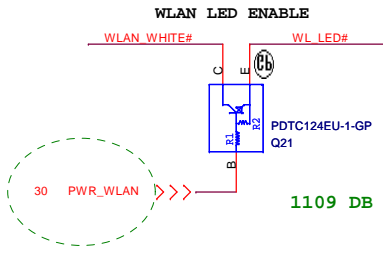

1113 DB
Close to PWR1

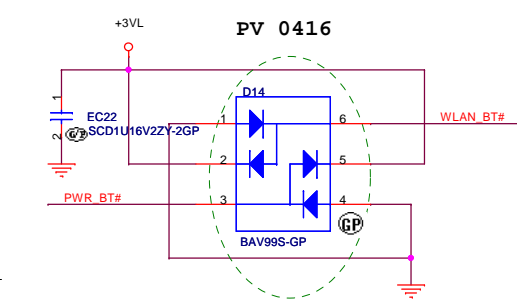
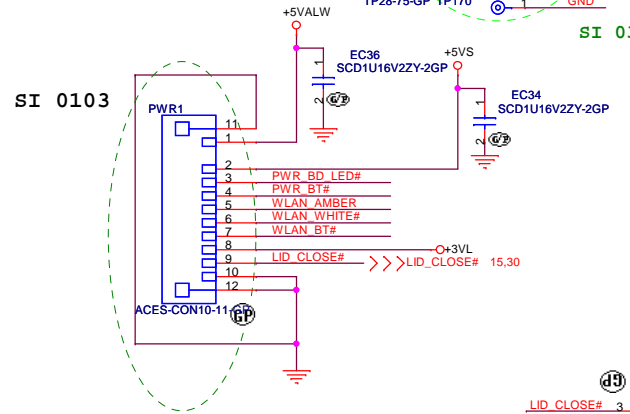

WIRELESS SWITCH

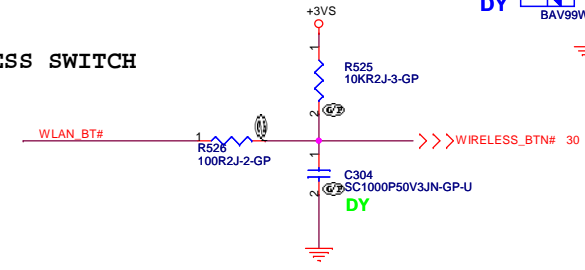

POWER SWITCH

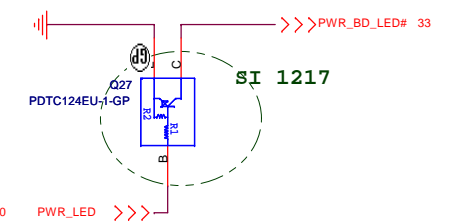
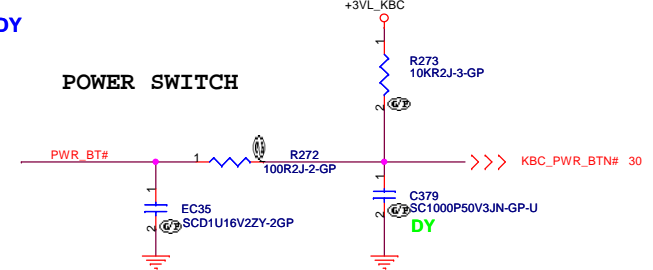

<Variant Name>

緯創資通 Wistron Corporation
21F, 88, Sec.1, Hsin Tai Wu Rd., Hsichih,
Taipei Hsien 221, Taiwan, R.O.C.

Title: **FLASH and Debug**

Size A3	Document Number	Rev
	Astrosphere	SA

Date: Wednesday, March 04, 2009 Sheet 31 of 44

Internal Keyboard Connector

30 KROW[1..8] <<<< <<<<
30 KCOL[1..18] <<<< <<<<

Keyboard matrix (from vendor)

	US	Eur	Jap
MATRIXID1#	0	1	0
MATRIXID2#	0	0	1

SI 0310

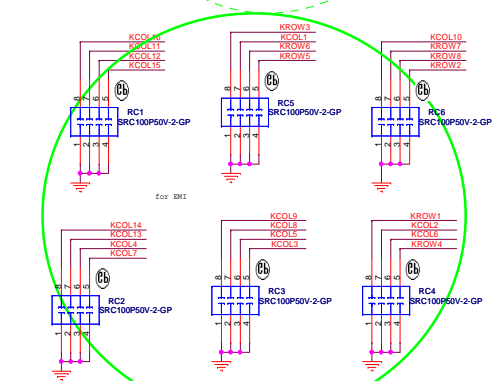
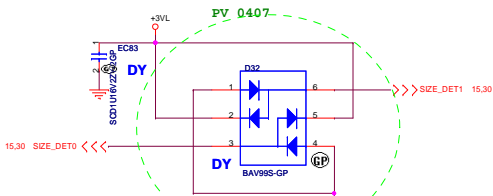
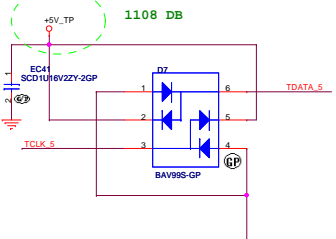
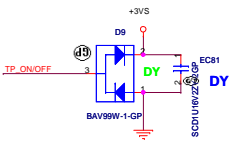

-4 0105_09

1114 DB
Close to KB1

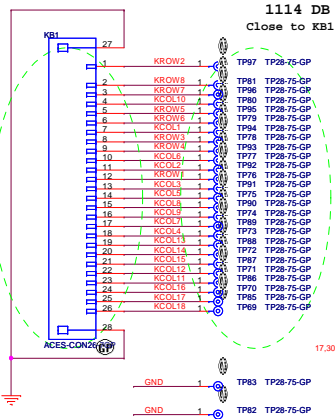

17,30,40 PM_SLP_S5 >>>>

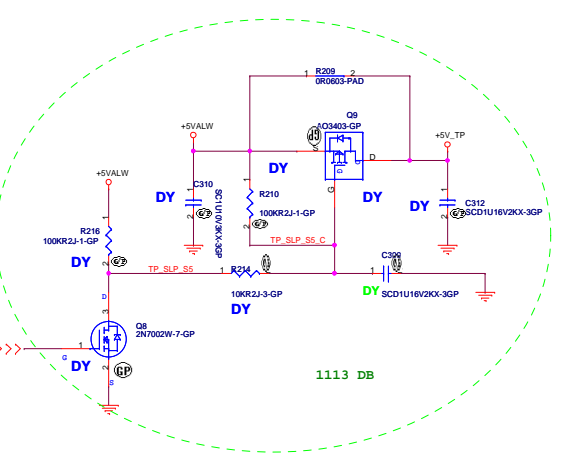

1113 DB

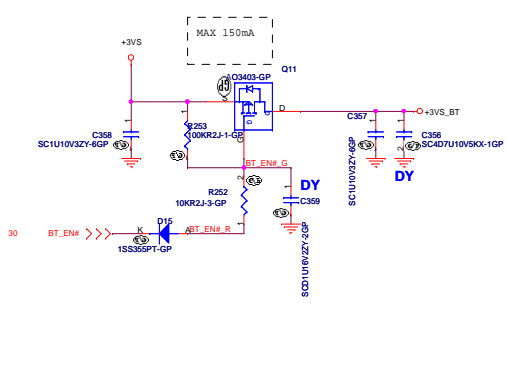

1108 DB

TouchPad Connector

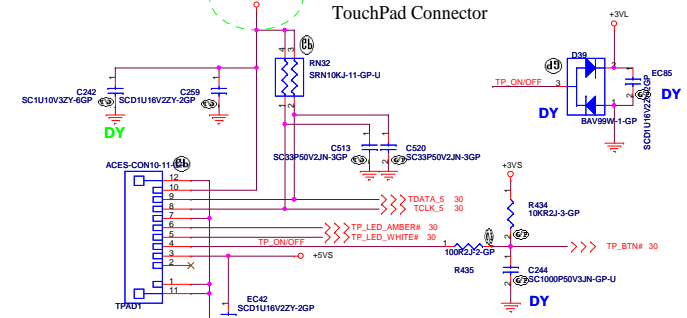

SI 0103

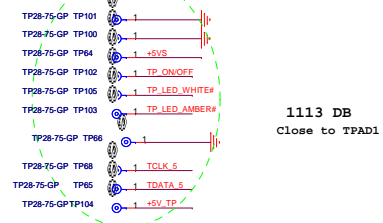

1113 DB
Close to TPAD1

BT

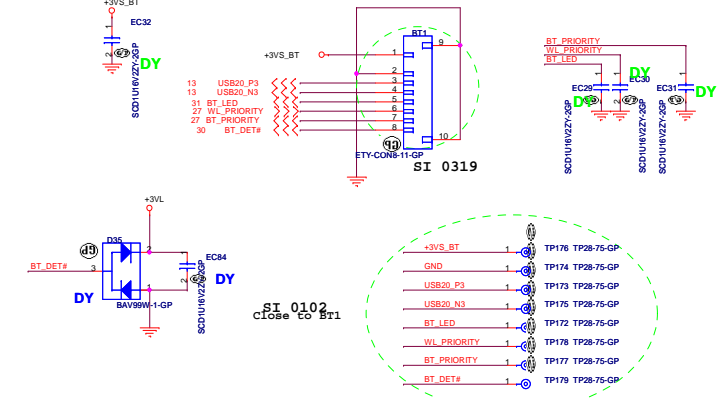

SI 0102
Close to BT1

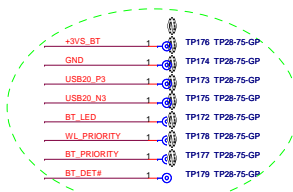

-Variant Name-

緯創資通 Wistron Corporation
21F, 88, Sec.1, Hsin Tai Wu Rd., Hsinchu, Taipei Hsin 221, Taiwan, R.O.C.

File		KeyBoard-CONN	
Size	A2	Document Number	Rev
Date: Wednesday, March 04, 2009		Astrosphere	SA
		Sheet	32 of 44

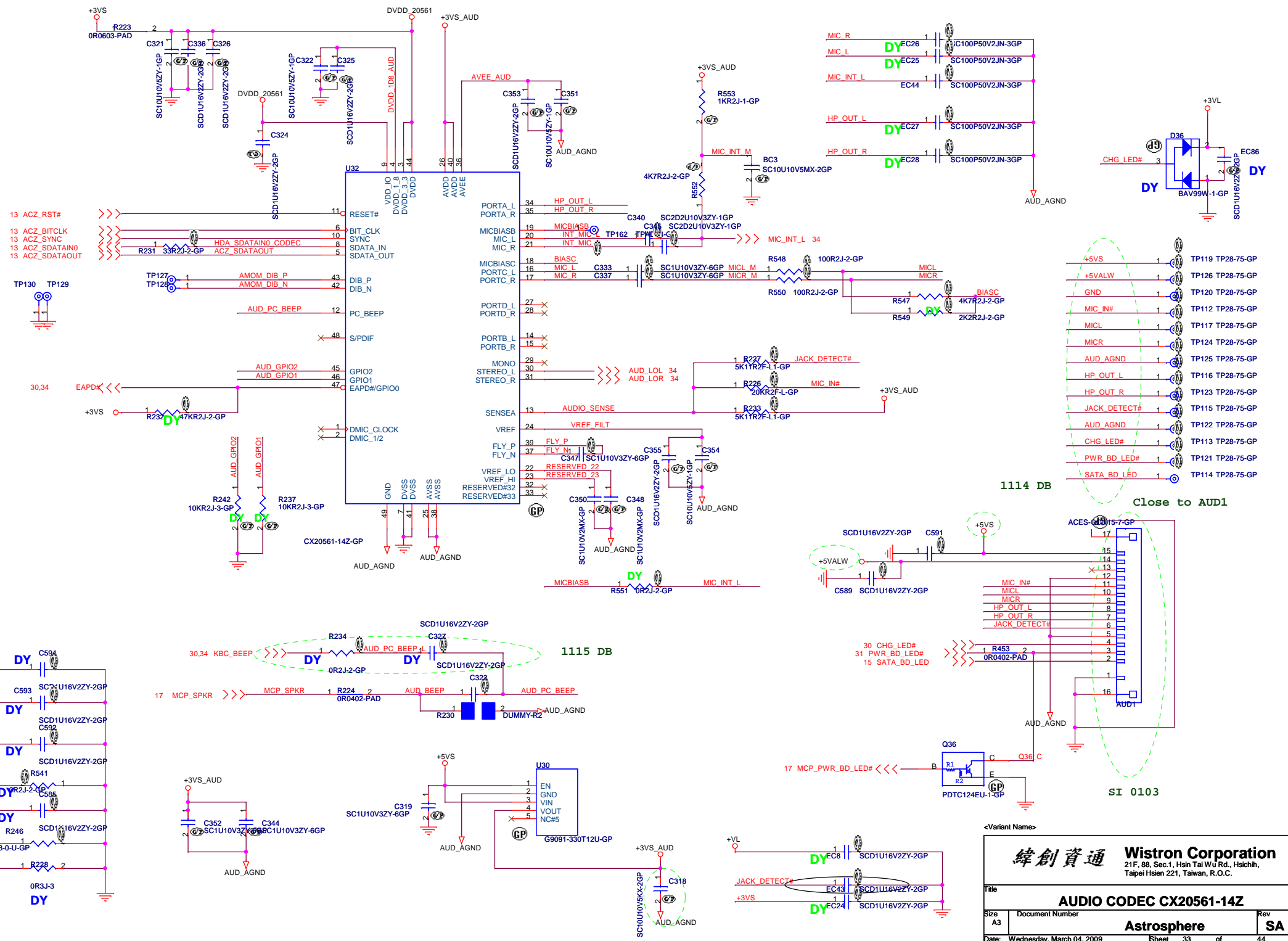

- TP119 TP28-75-GP
- TP126 TP28-75-GP
- TP120 TP28-75-GP
- TP112 TP28-75-GP
- TP117 TP28-75-GP
- TP124 TP28-75-GP
- TP125 TP28-75-GP
- TP116 TP28-75-GP
- TP123 TP28-75-GP
- TP115 TP28-75-GP
- TP122 TP28-75-GP
- TP113 TP28-75-GP
- TP121 TP28-75-GP
- TP114 TP28-75-GP

1114 DB

Close to AUD1

緯創資通 Wistron Corporation
21F, 88, Sec.1, Hsin Tai Wu Rd., Hsichih, Taipei Hsein 221, Taiwan, R.O.C.

Title: **AUDIO CODEC CX20561-14Z**

Size A3	Document Number	Rev SA
Astrosphere		
Date: Wednesday, March 04, 2009		Sheet 33 of 44

1122DB

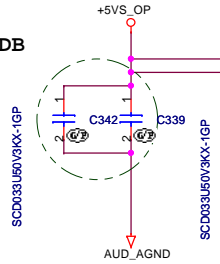

Set to 15.6DB

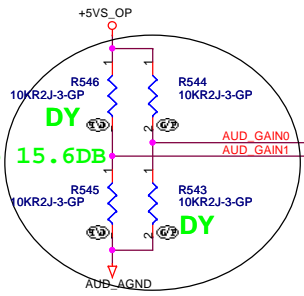

GAIN0	GAIN1	Av (dB)
0	0	6
0	1	10
1	0	15.6
1	1	21.6

Change to G1431F2U-GP

1113 DB

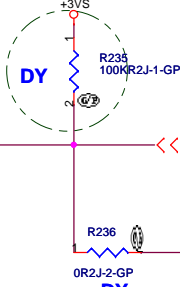

change to 470P

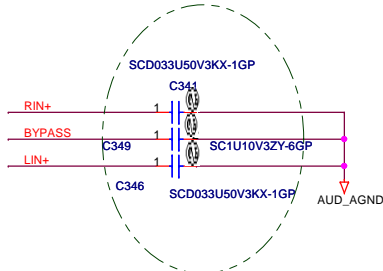

MIC

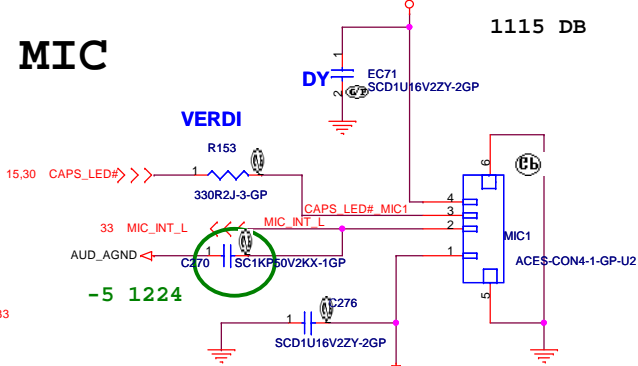

1115 DB

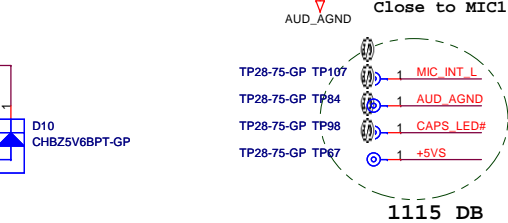

Speaker

1113 DB

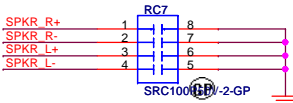

Close to SPKR1

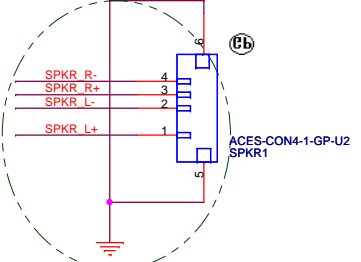
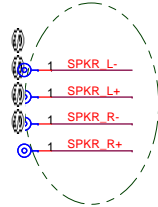

<Variant Name>

緯創資通 Wistron Corporation
21F, 88, Sec.1, Hsin Tai Wu Rd., Hsichih, Taipei Hsien 221, Taiwan, R.O.C.

Title: **AUDIO AMP G1431**

Size: A3 Document Number: **Astrosphere** Rev: **SA**

Date: Wednesday, March 04, 2009 Sheet 34 of 44

Run Power

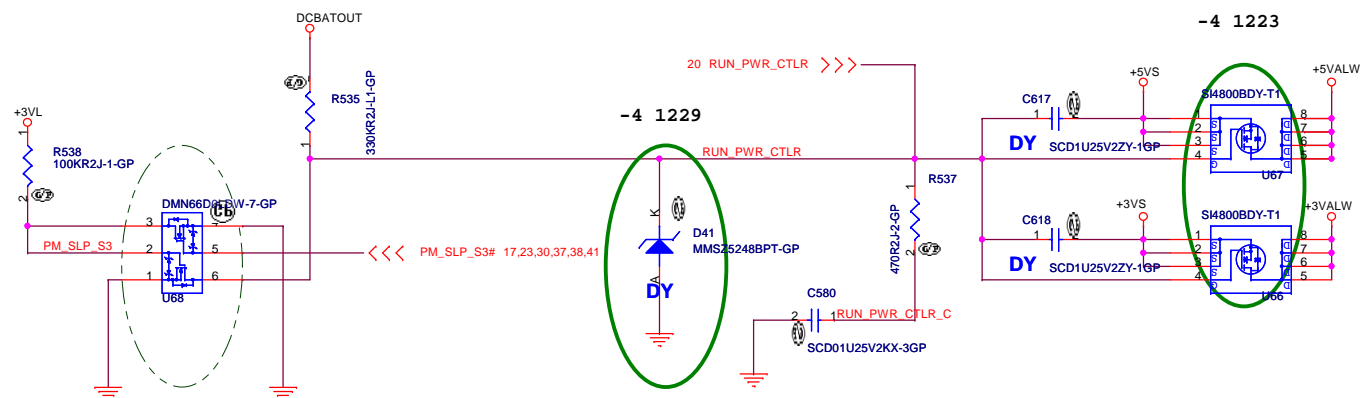

change P/N to 84.DMN66.03F

Run Power

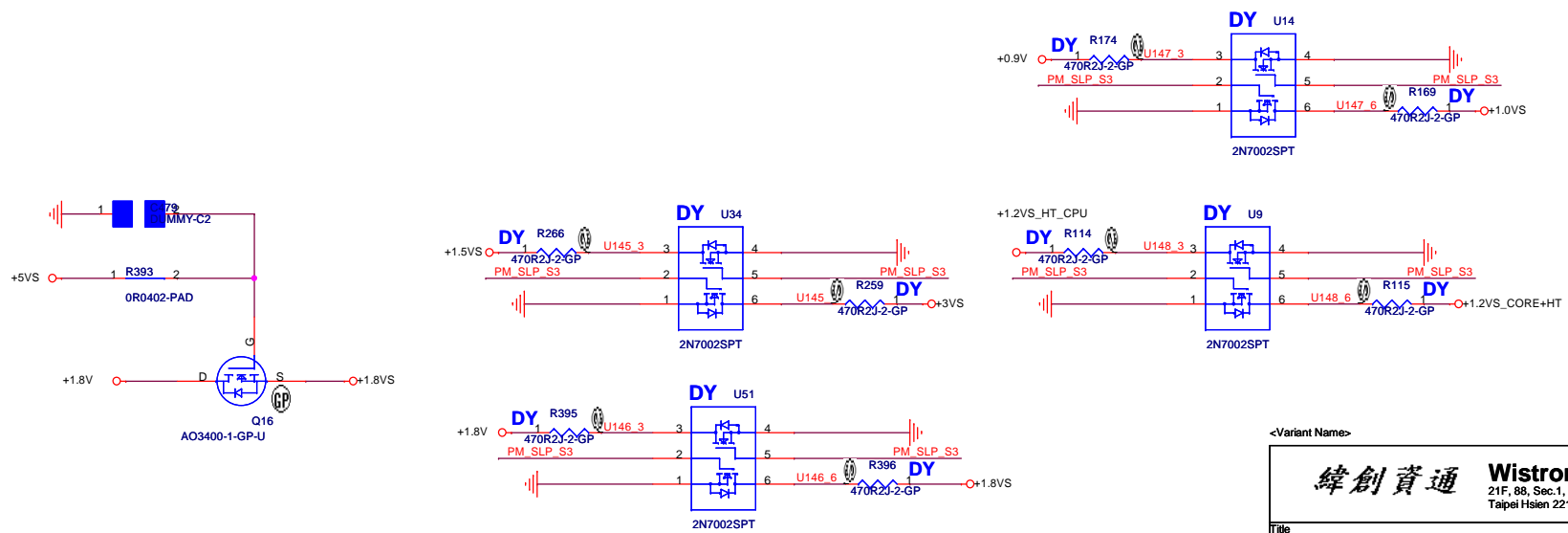

<Variant Name>

緯創資通 Wistron Corporation
21F, 88, Sec.1, Hsin Tai Wu Rd., Hsichih,
Taipei Hsien 221, Taiwan, R.O.C.

Title: **PWRPLANE&RESETLOGIC**

Size: A3	Document Number: Astrosphere	Rev: SA
Date: Wednesday, March 04, 2009	Sheet: 35	of 44

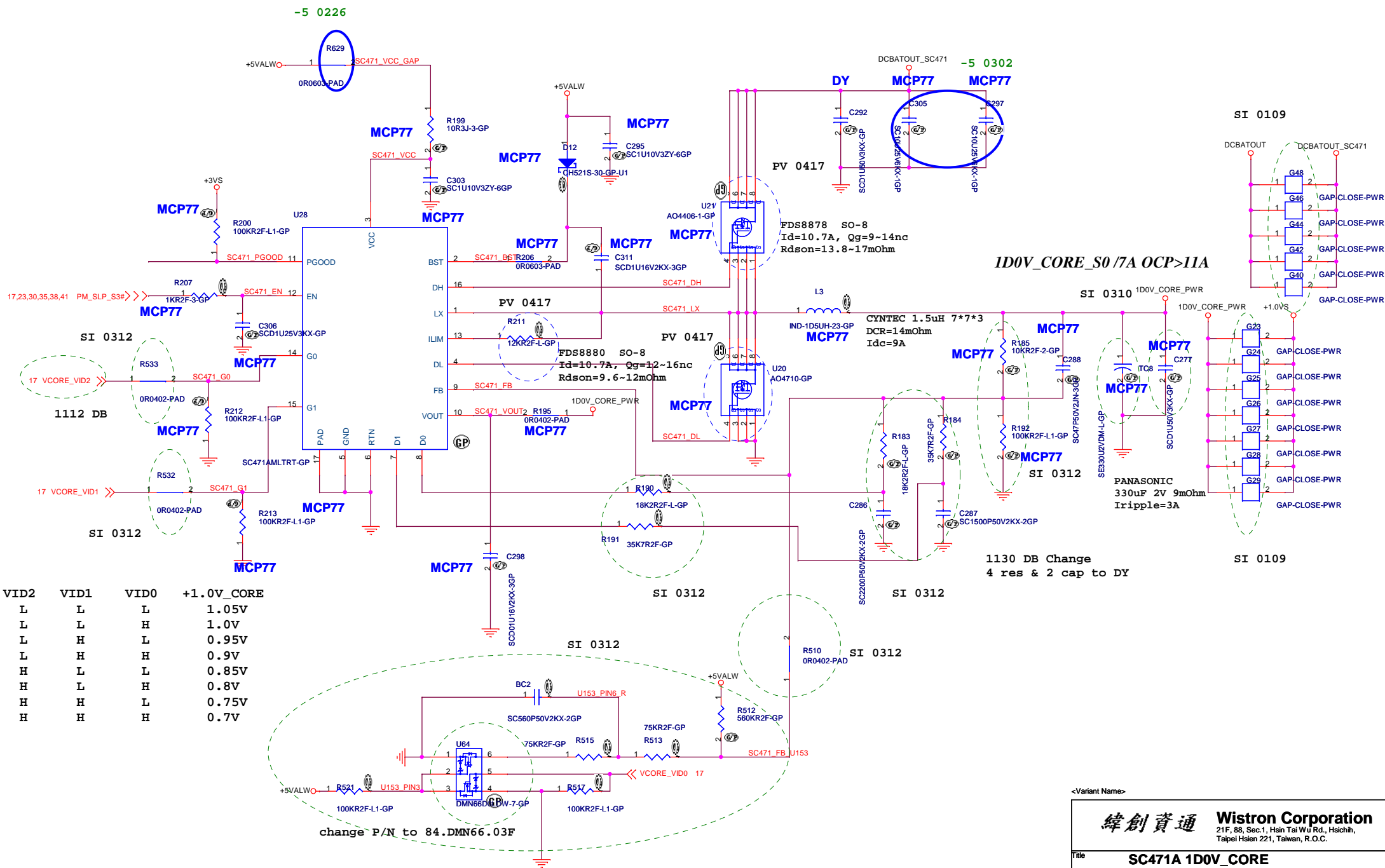

VID2	VID1	VID0	+1.0V_CORE
L	L	L	1.05V
L	L	H	1.0V
L	H	L	0.95V
L	H	H	0.9V
H	L	L	0.85V
H	L	H	0.8V
H	H	L	0.75V
H	H	H	0.7V

<Variant Name>

緯創資通 Wistron Corporation
 21F, 88, Sec.1, Hsin Tai Wu Rd., Hsichih,
 Taipei Hsien 221, Taiwan, R.O.C.

Title: **SC471A 1D0V_CORE**

Size A3	Document Number	Astrosphere	Rev SA
---------	-----------------	-------------	--------

Date: Wednesday, March 04, 2009 Sheet 37 of 44

A

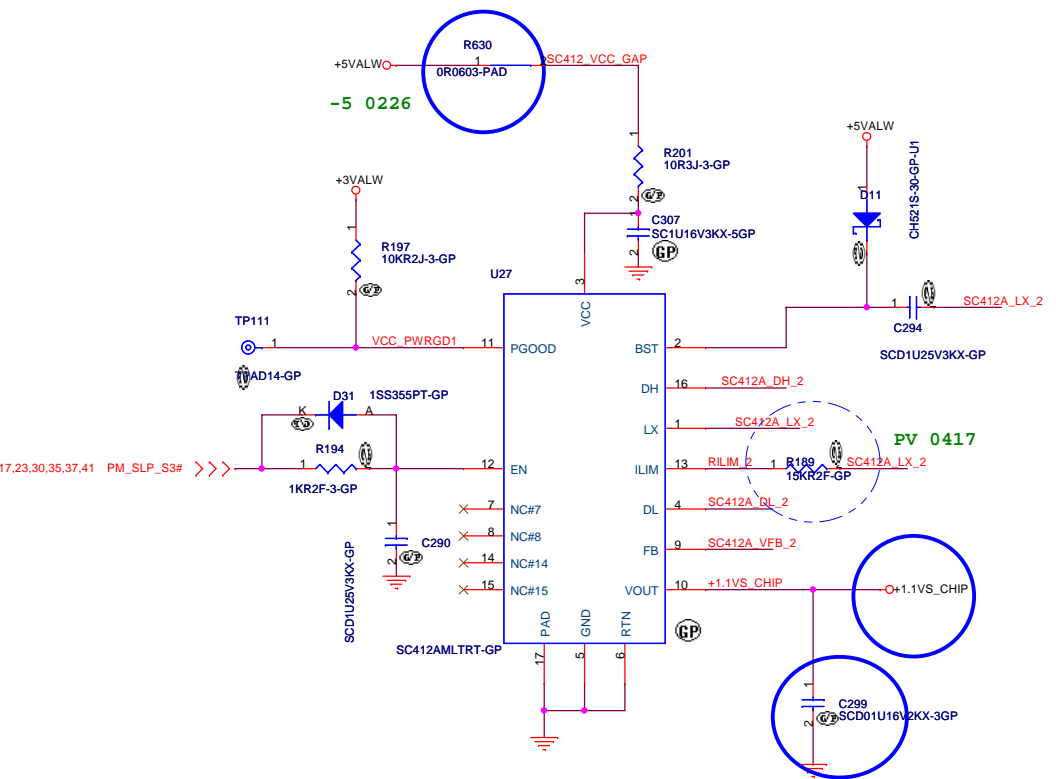

SI 0109

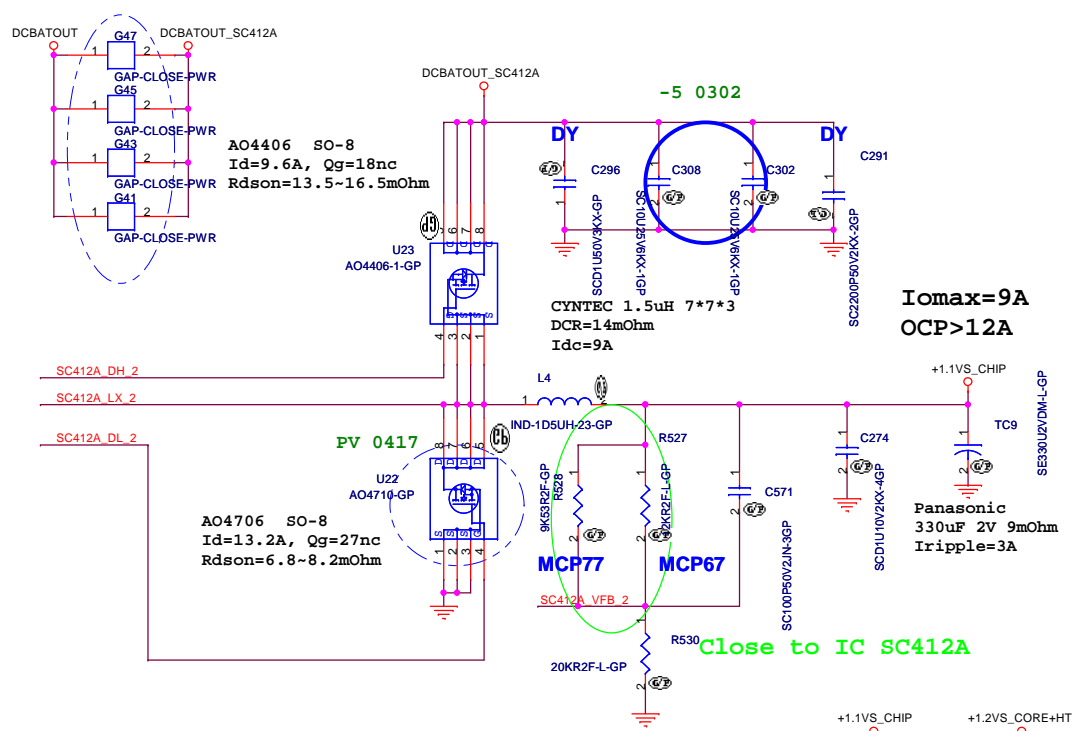

MCP67: 1.2V (R425/R426) = (12K/20K)
MCP77: 1.1V (R425/R426) = (9.53K/20K)

SI 0109

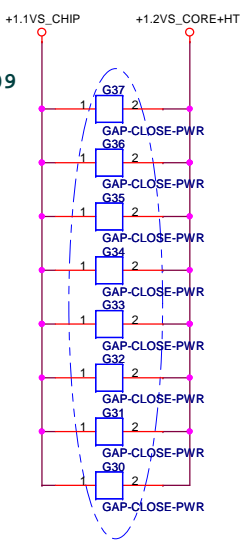

SI 0109

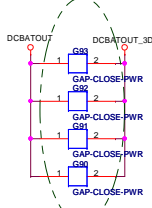

3.3V
Design Current =6A
OCP >8 A

SI 0109

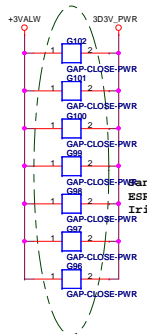

SI4800, SC=8
I_{id}=9A, Q_g=8.7-13nC
R_{daon}=23-30mohm

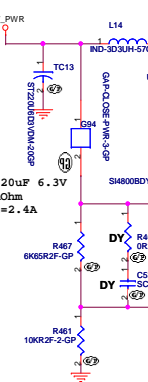

Sanyo 220uF 6.3V
ESR=25mOhm
Irripple=2.4A

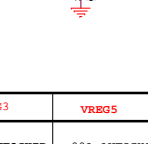

SI 0107

	GND	VREF	VREG3	VREG5
SKIPSEL	PWM	AUTOSKIP	00A AUTOSKIP	00A AUTOSKIP
TONSEL	200k/CH1 250k/CH2	245k/CH1 305k/CH2	300k/CH1 375k/CH2	365k/CH1 460k/CH2

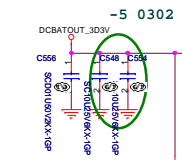

-5 0302



-5 0226



-5 0302

-5 0302

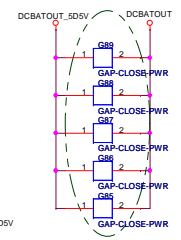

SI 0109

5V
Design Current =6A
OCP design >8A

SI 0109

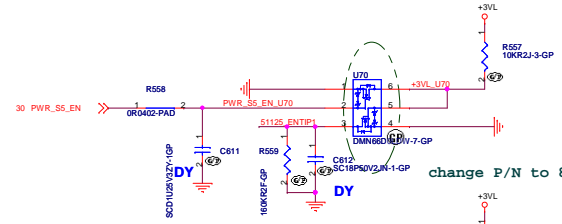
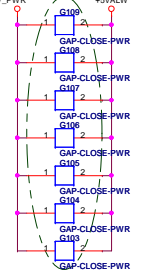

change P/N to 84.DMN66.03F

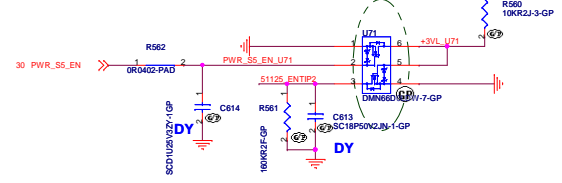

<Core Design>

TI TPS51116 for 1D8V and 0D9V

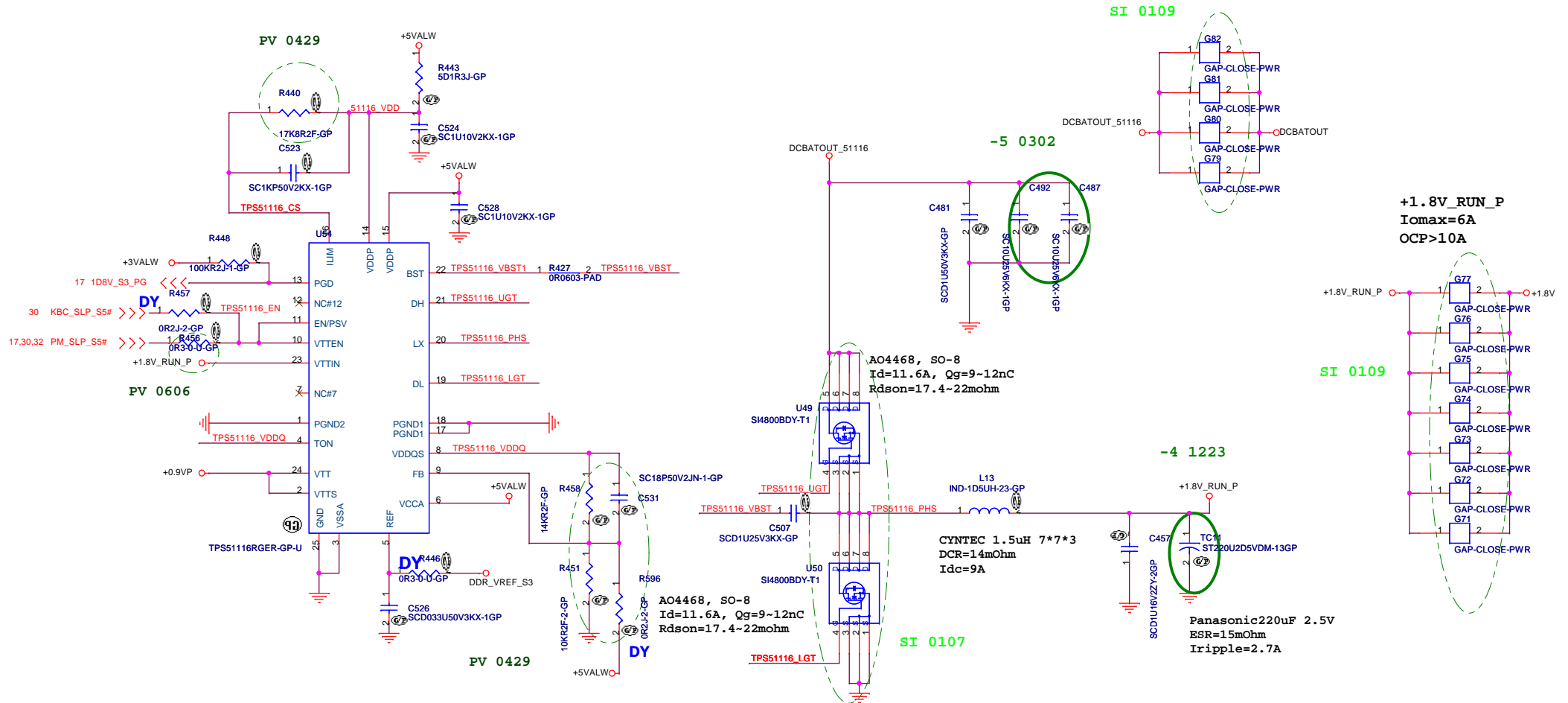

State	S3	S5	VDDP	VTTREF	VTT
S0	Hi	Hi	On	On	On
S3	Lo	Hi	On	On	Off(Hi-Z)
S4/S5	Lo	Lo	Off	Off	Off

<Core Design>

緯創資通 Wistron Corporation
21F, 88, Sec.1, Hsin Tai Wu Rd., Hsichih, Taipei Hsien 221, Taiwan, R.O.C.

Title: **TPS51116 1D8V/0D9V**

Size A3	Document Number	Rev
	Astrosphere	SA

Date: Wednesday, March 04, 2009 Sheet 40 of 44

